

# PLANE PRINT

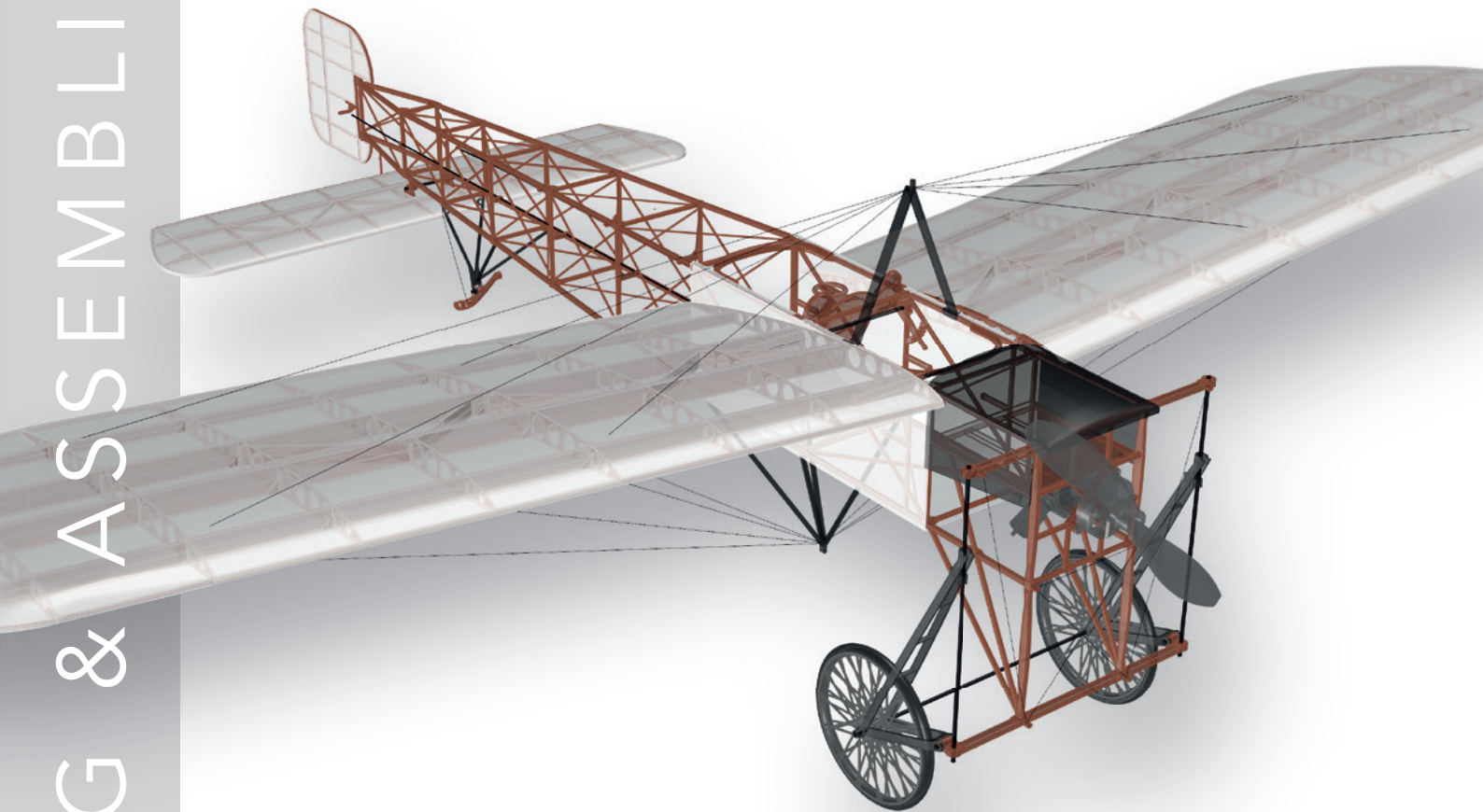

## PLANE PRINT *Blériot XI*



**NOTE:** Slicing only works with CURA!



You can find the STL data at [www.planeprint.com](http://www.planeprint.com)

# PLANE PRINT *Blériot XI*

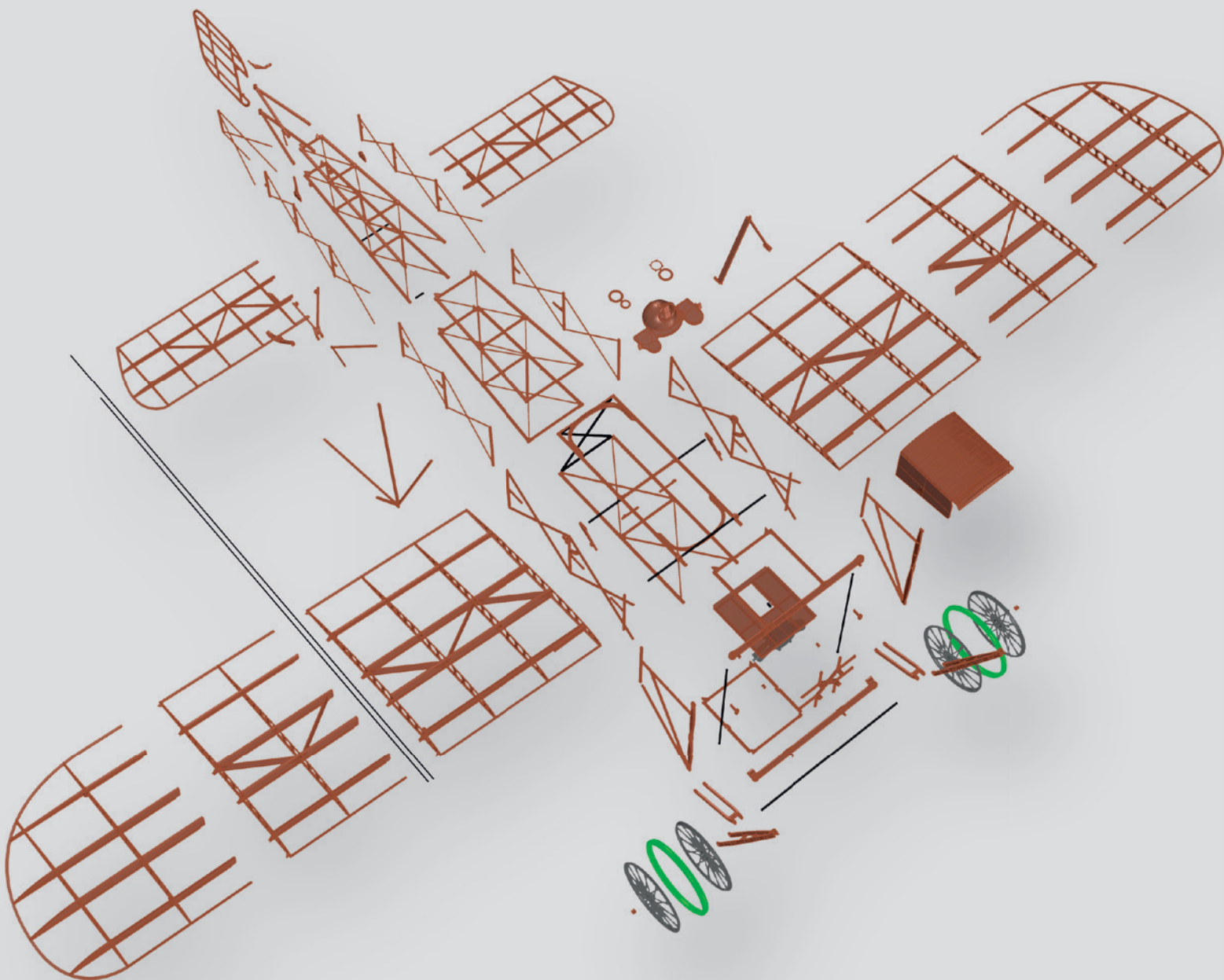

 PLA  TPU  CARBON

# RC Components

**ENGINE** AXI 2203/40 VPP or comparable indoor-20 grams-motors.

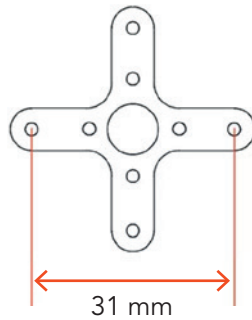

**PROP** 8x3.8 or comparable, also possible 8x3, 8x4

**BEC-CONTROLLER** 15 A (one matching the motor)

**RECEIVER** 3 Channel

**BATTERY** 2S Lipo, 650 MaH (ideal weight 38 grams)

**SERVOS**

- Stemedu Micro 3.7g Servo GH-S37D
- PLANET-HOBBY ECO PLUS
- PICCO 8 DIGITAL SERVO
- Diamond D47
- Hitec HS 40 Eco Servo 4,8g

or similar in the same size, **2 pieces**

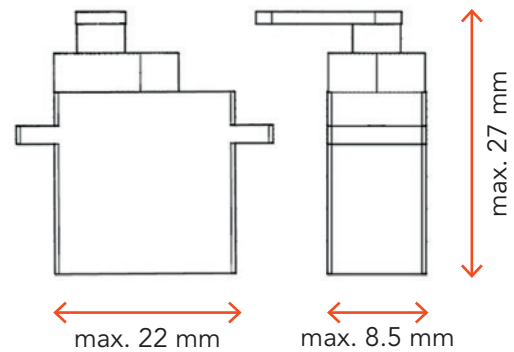

There are also ready-made indoor drive sets with motor, servos and battery available from many dealers.

## Required accessoires – basic equipment

- Tough PLA (or PLA), ~200 grams
- LW TPU like VarioShore, ~20 grams (or TPU A95)
- CA super glue (liquid and liquid medium or thick)
- CA activator
- Wood glue
- Carbon rod  $\varnothing 2 \times 1000$ mm, 1 piece
- Carbon rod  $\varnothing 0.8 \times 1000$ mm (also possible is  $\varnothing 1$ mm), 2 pieces
- Steel wire  $\varnothing 0.8$ mm (a few short pieces for the linkage)
- Parchment or tissue paper (or another light paper to cover the wings) →
- black and gold acrylic paint and thin gray twine
- some tapping screws  $\varnothing 2$  mm
- Hair gums or small rubber bands

## Tools

Cutter knife, Scissors, small Philips screwdriver, Sandpaper, small brush



# Printing the parts – Printing profiles

This manual is constantly being improved and supplemented, we recommend downloading the **latest version** from our website **before building**.

For slicing all Planeprint models, these profiles have to be created in Cura:

PROFILE P1\_Fullbody  
PROFILE P2\_Hollowbody  
PROFILE P3\_Surface  
PROFILE P4\_Flex  
PROFILE P5\_Gyroid

You can find the description at [www.planepprint.com/print](http://www.planepprint.com/print)

## Important for the 1-wall-print (P3, P5)!

In order to print airfoils of the lowest possible weight with high stability, it is necessary to print with only one wall line (Nozzle 0.4 mm). Decisive here is the adhesion between the layers! To achieve this, you must print at a much higher temperature than normal. As a **guideline**, 230° C is a good starting point. The parts-cooling fan should be set to 0% or a maximum of 20%. Since not every printer works the same, it may be necessary to make small adjustments to these settings.

The Blériot XI requires :

**PROFILE P1\_Fullbody**, **PROFILE P2\_Hollowbody** and **PROFILE P4\_Flex**



The development of a complex, airworthy RC flight model to express on any standard 3D printer is a very complex and extensive process. Therefore, we appeal to your fairness not to forward the STL data you have acquired to third parties.

**Thank you for your understanding and have fun with your PLANEPRINT MODEL!**

# PROFILE P1\_Fullbody Tough PLA (or PLA)

The following parts must be sliced with the PROFILE P1\_Fullbody.  
Please note the additional settings for the individual parts!

## P1\_Elevator\_bl.stl

**MATERIAL** PLA, Weight: ~ 10 g

### ADDITIONAL SETTINGS

None required

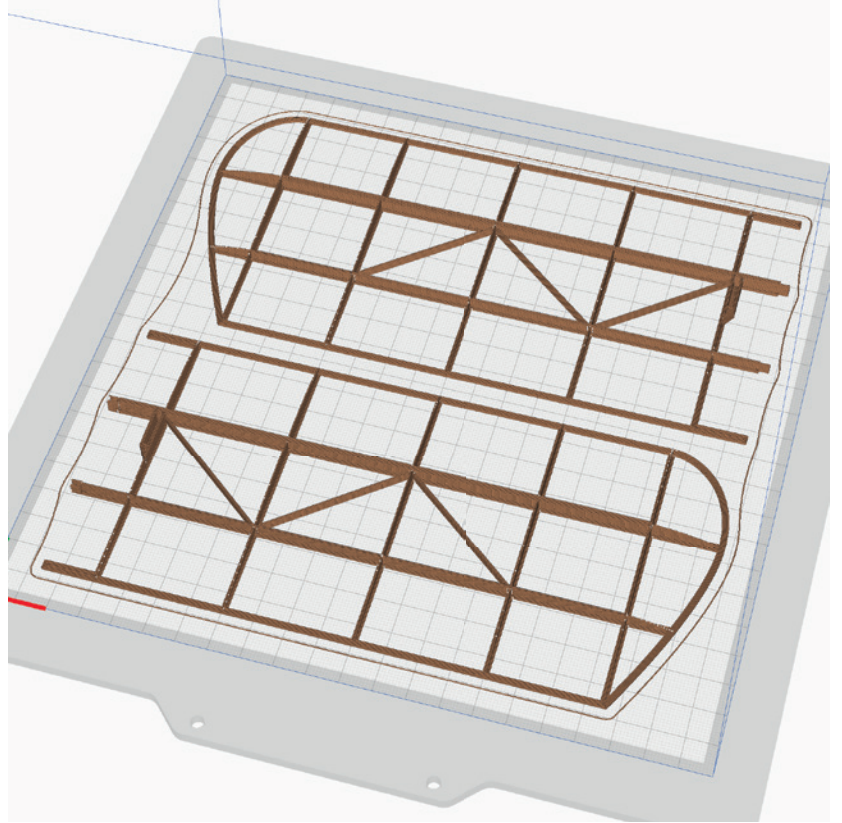

## P1\_Gear\_bl.stl

**MATERIAL** PLA, Weight: ~ 6 g

### ADDITIONAL SETTINGS

None required

**TIP** These parts should be black, you can paint them with acrylic paint or print them with black filament.

This part is not needed  
(serves to optimize the paths)

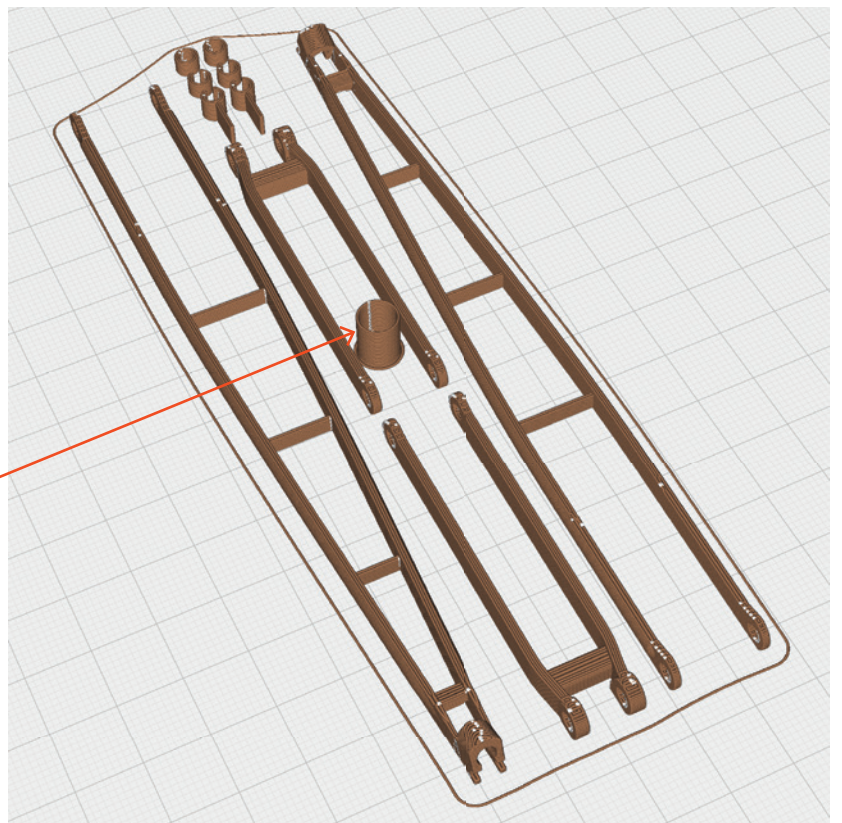

# PROFILE P1\_Fullbody Tough PLA (or PLA)

The following parts must be sliced with the PROFILE P1\_Fullbody.  
Please note the additional settings for the individual parts!

## P1\_Grid 1 side\_bl.stl

**MATERIAL** PLA, Weight: ~ 7 g

### ADDITIONAL SETTINGS

None required

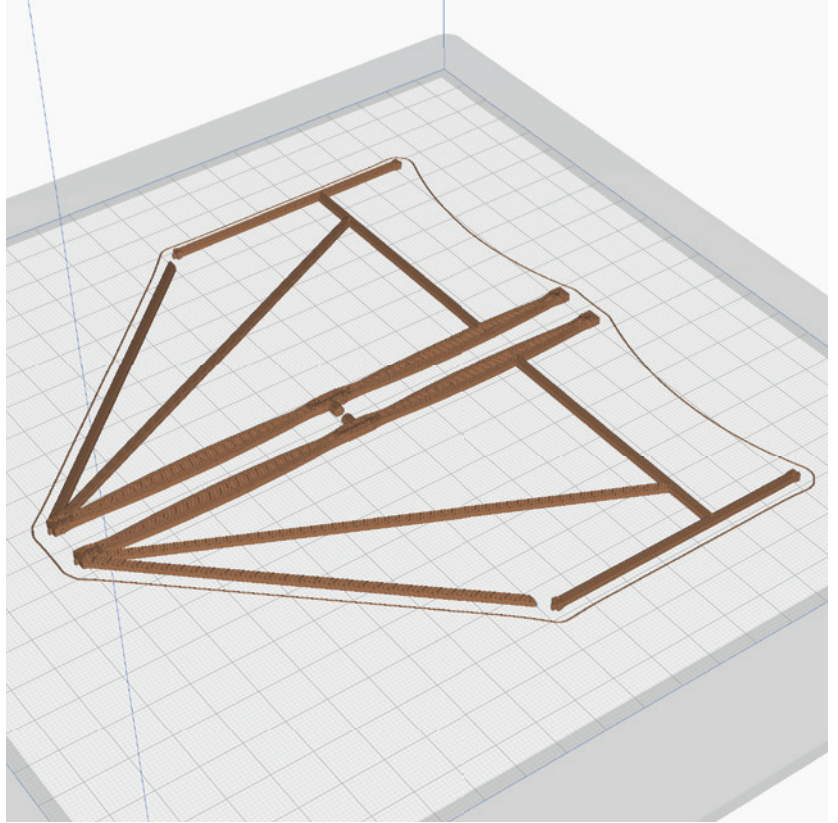

## P1\_Grid 1\_bl.stl

**MATERIAL** PLA, Weight: ~ 15 g

### ADDITIONAL SETTINGS

None required

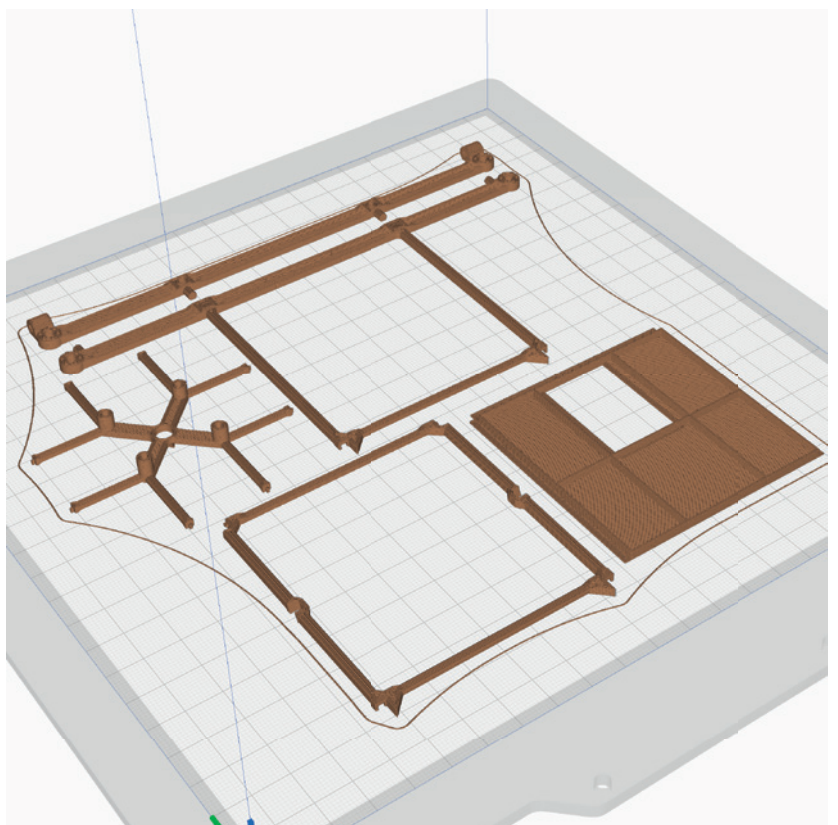

# PROFILE P1\_Fullbody Tough PLA (or PLA)

The following parts must be sliced with the PROFILE P1\_Fullbody.  
Please note the additional settings for the individual parts!

## P1\_Grid 2 side\_bl.stl

**MATERIAL** PLA, Weight: ~ 6 g

### **ADDITIONAL SETTINGS**

None required

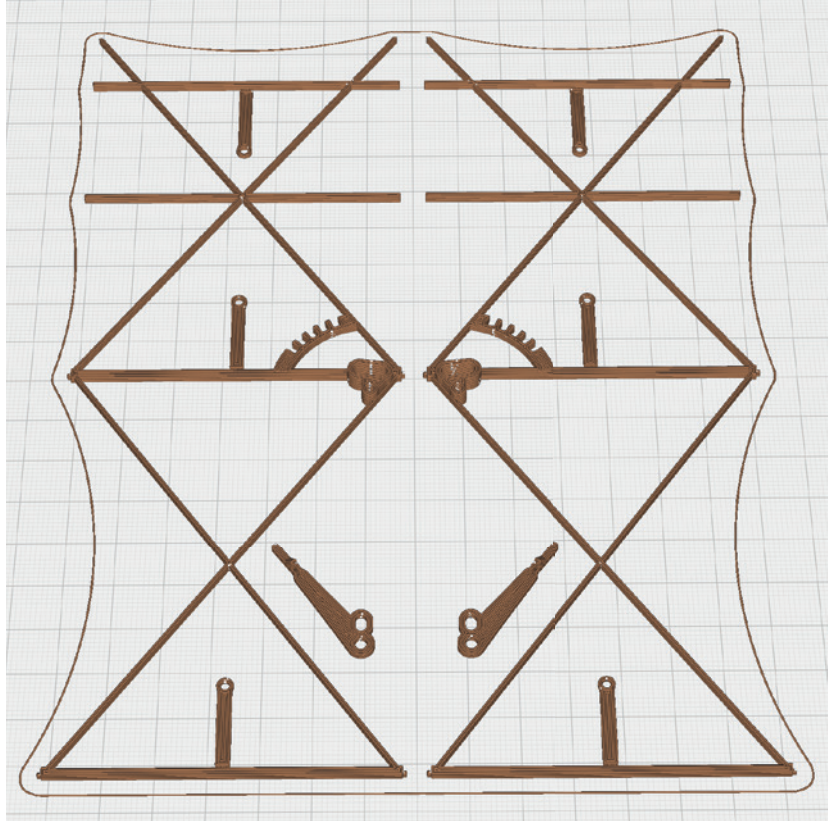

## P1\_Grid 2\_bl.stl

**MATERIAL** PLA, Weight: ~ 10 g

### **ADDITIONAL SETTINGS**

None required

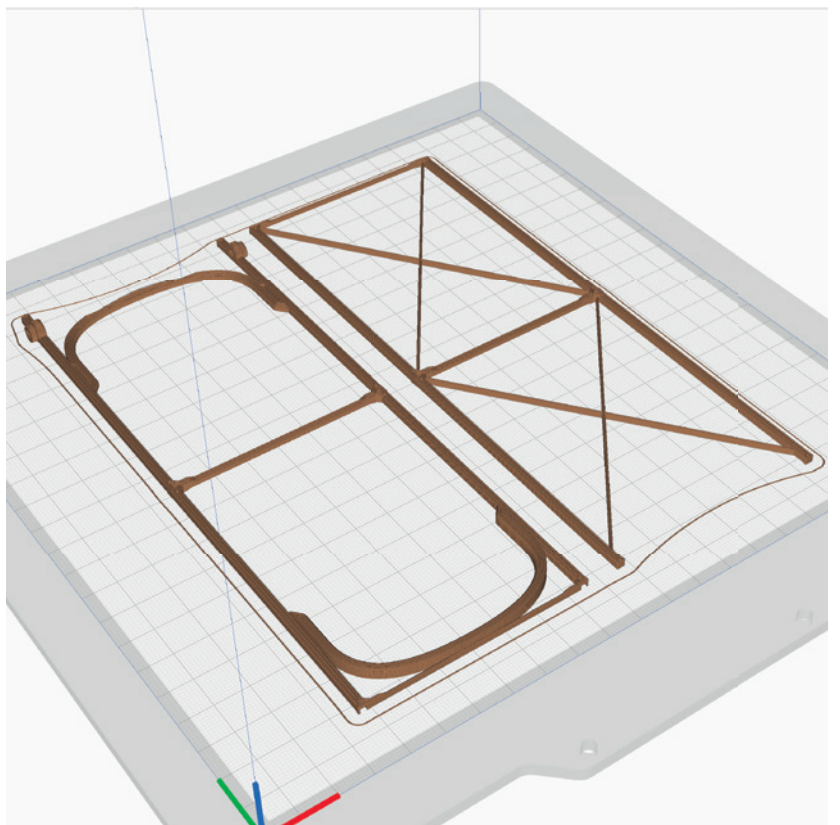

# PROFILE P1\_Fullbody Tough PLA (or PLA)

The following parts must be sliced with the PROFILE P1\_Fullbody.  
Please note the additional settings for the individual parts!

## P1\_Grid 3 side\_bl.stl

**MATERIAL** PLA, Weight: ~ 3 g

### ADDITIONAL SETTINGS

None required

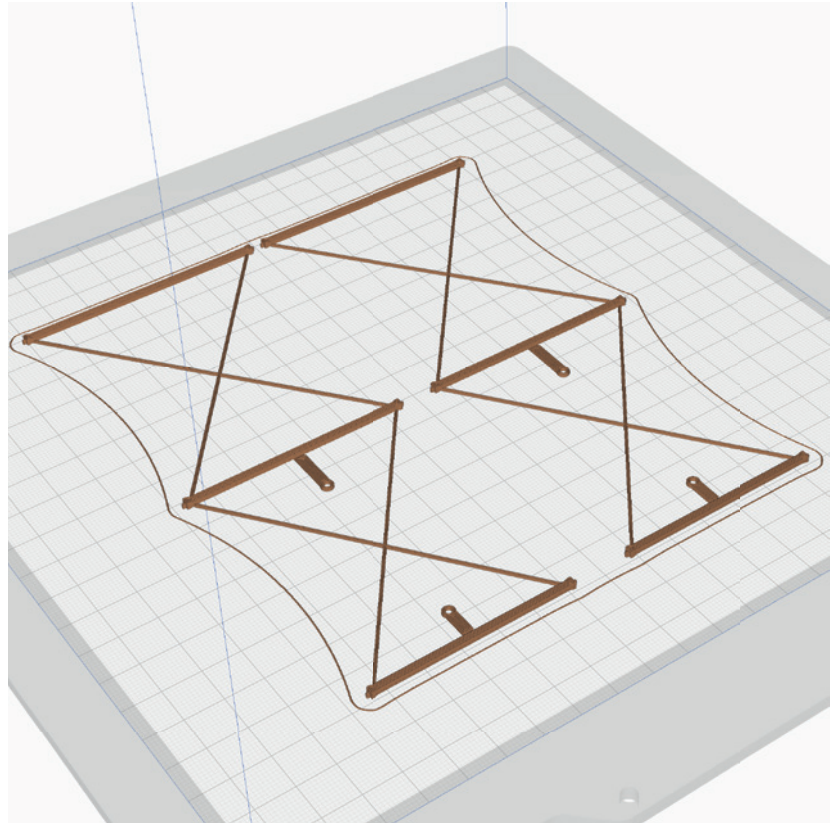

## P1\_Grid 3\_bl.stl

**MATERIAL** PLA, Weight: ~ 8 g

### ADDITIONAL SETTINGS

None required

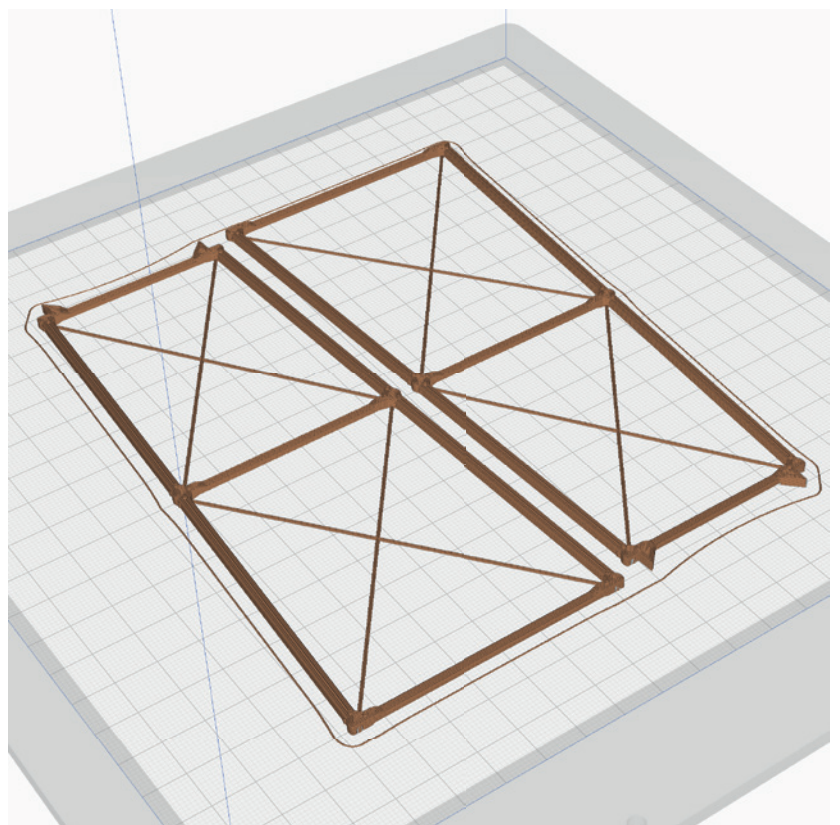

# PROFILE P1\_Fullbody Tough PLA (or PLA)

The following parts must be sliced with the PROFILE P1\_Fullbody.  
Please note the additional settings for the individual parts!

## P1\_Grid 4 down\_bl.stl

**MATERIAL** PLA, Weight: ~ 4 g

### ADDITIONAL SETTINGS

None required

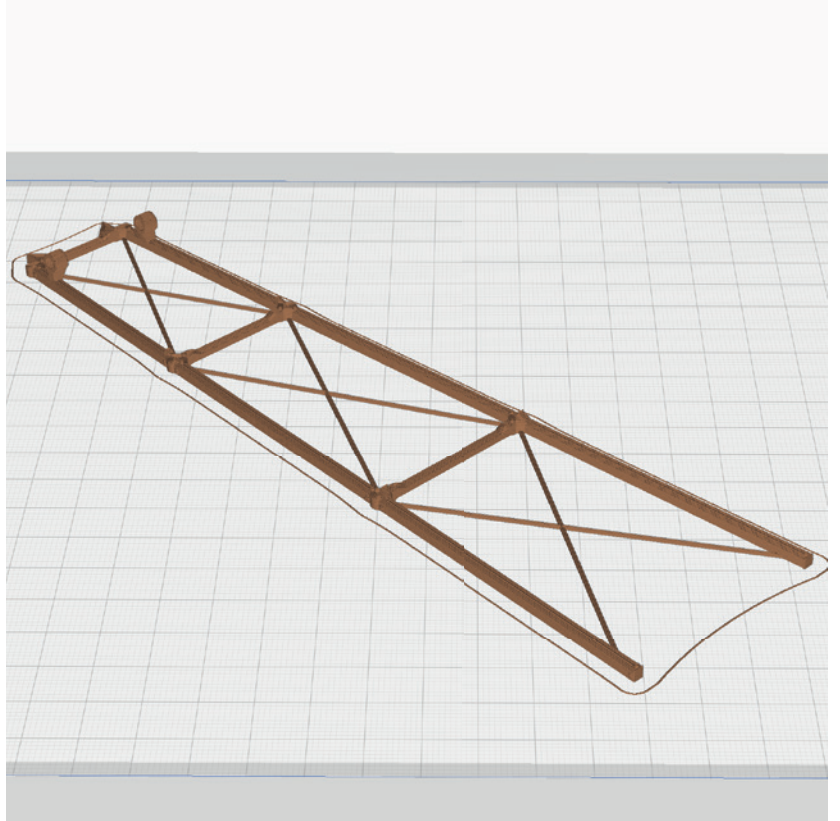

## P1\_Grid 4 side\_x2\_bl.stl

**MATERIAL** PLA, Weight: ~ 1 g

### ADDITIONAL SETTINGS

None required

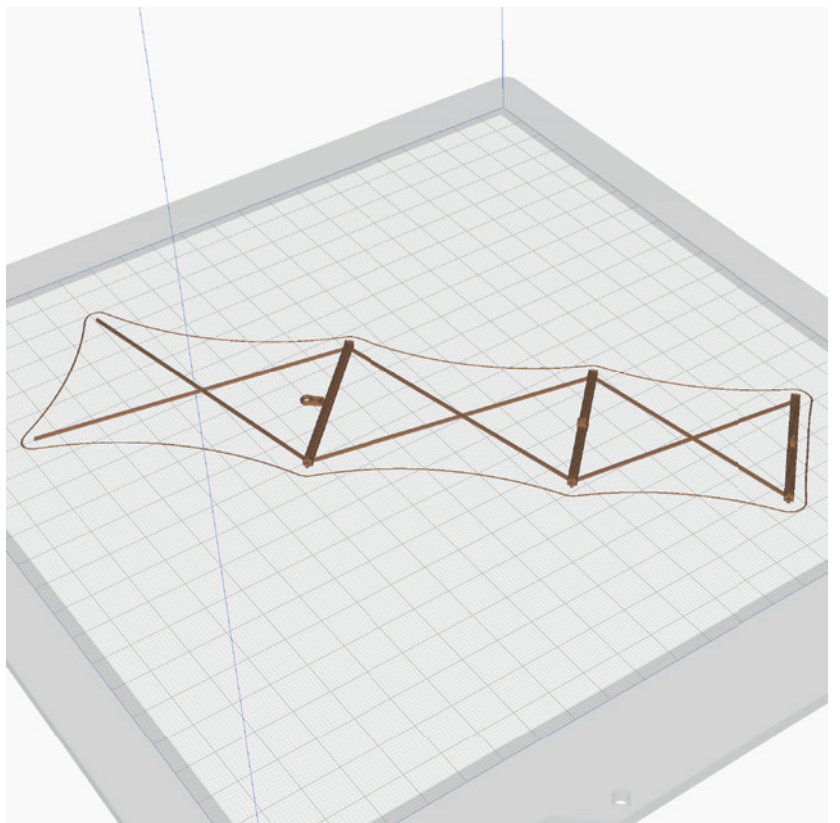

# PROFILE P1\_Fullbody Tough PLA (or PLA)

The following parts must be sliced with the PROFILE P1\_Fullbody.  
Please note the additional settings for the individual parts!

## P1\_Grid 4 up\_bl.stl

**MATERIAL** PLA, Weight: ~ 4 g

### **ADDITIONAL SETTINGS**

None required

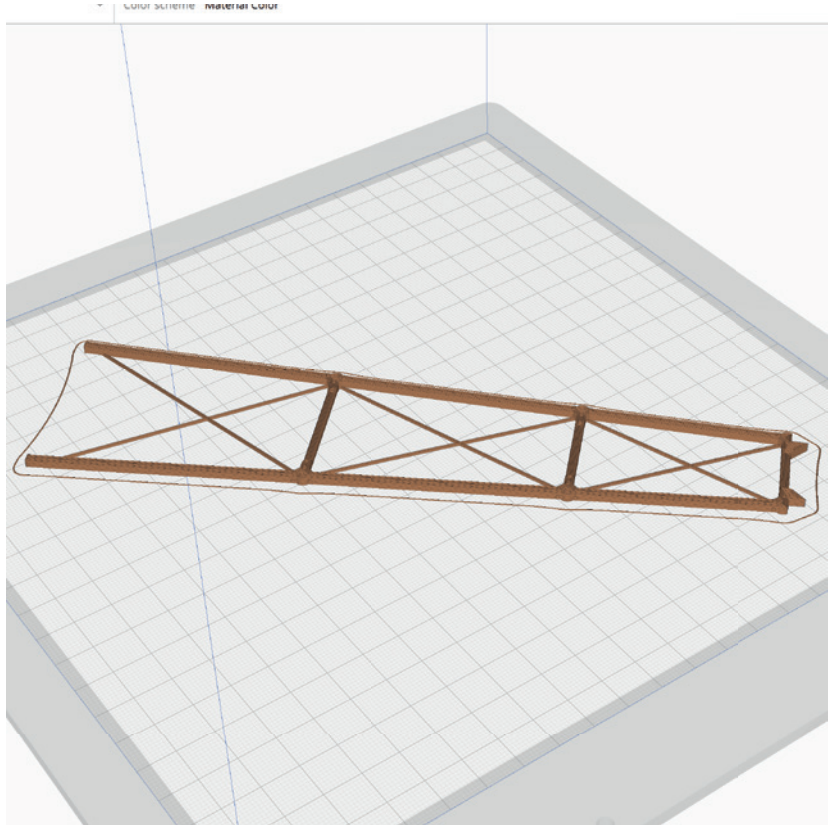

## P1\_Grid 5\_bl.stl

**MATERIAL** PLA, Weight: ~ 3 g

### **ADDITIONAL SETTINGS**

None required

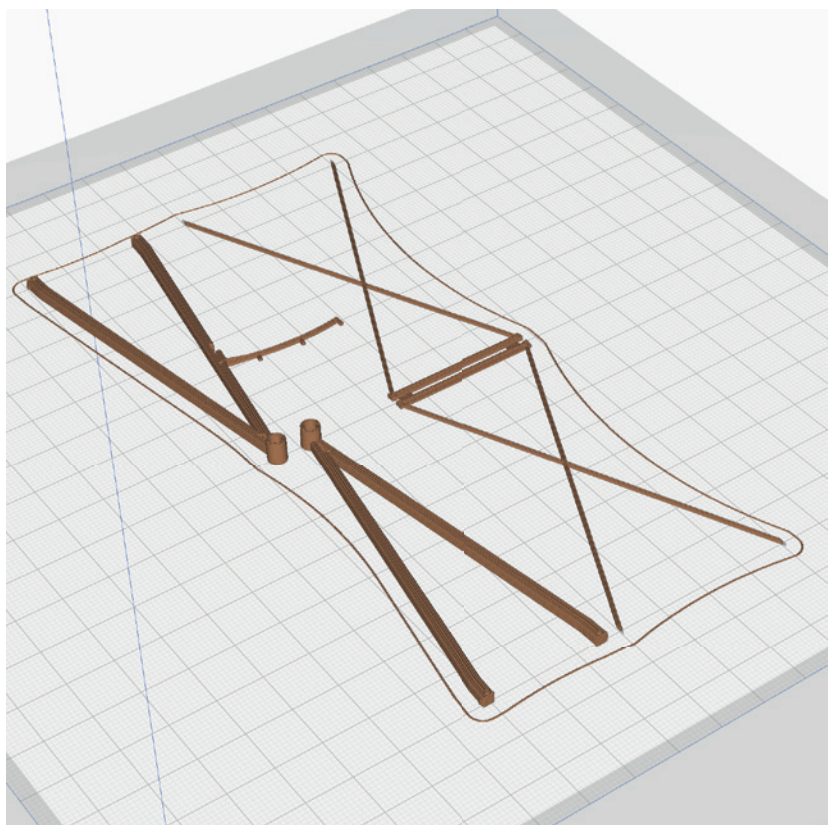

# PROFILE P1\_Fullbody Tough PLA (or PLA)

The following parts must be sliced with the PROFILE P1\_Fullbody.  
Please note the additional settings for the individual parts!

## P1\_Grid parts\_bl.stl

**MATERIAL** PLA, Weight: ~ 5 g

### ADDITIONAL SETTINGS

None required

**TIP** These parts should be black, you can paint them with acrylic paint or print them with black filament.

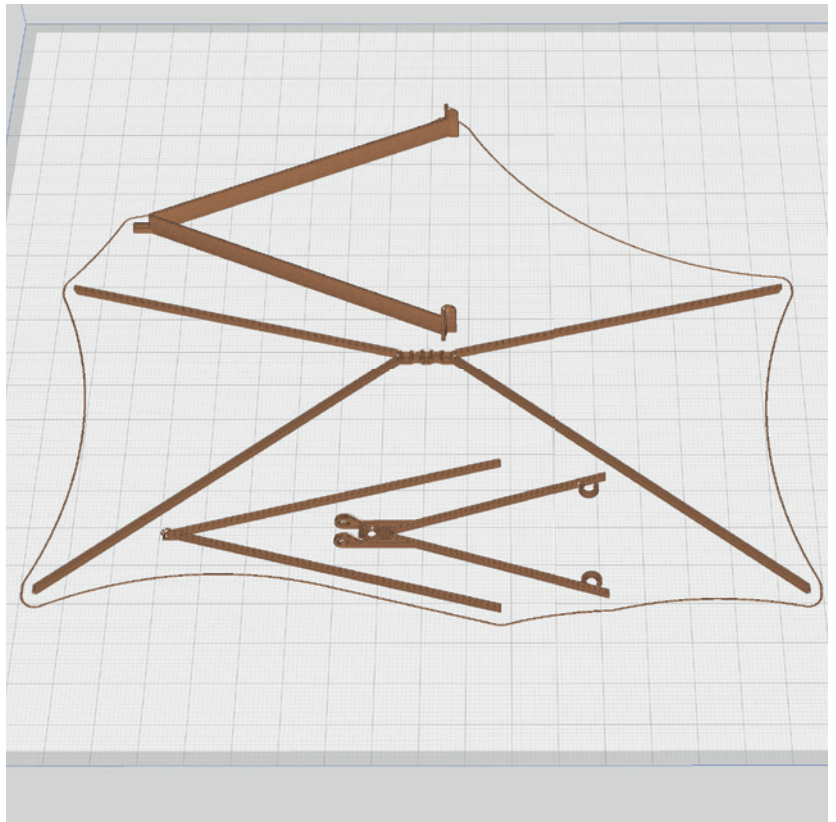

## P1\_Instruments\_bl.stl

**MATERIAL** PLA, Weight: ~ 0 g

### ADDITIONAL SETTINGS

None required

**TIP** These parts should be black, you can paint them with acrylic paint or print them with black filament.

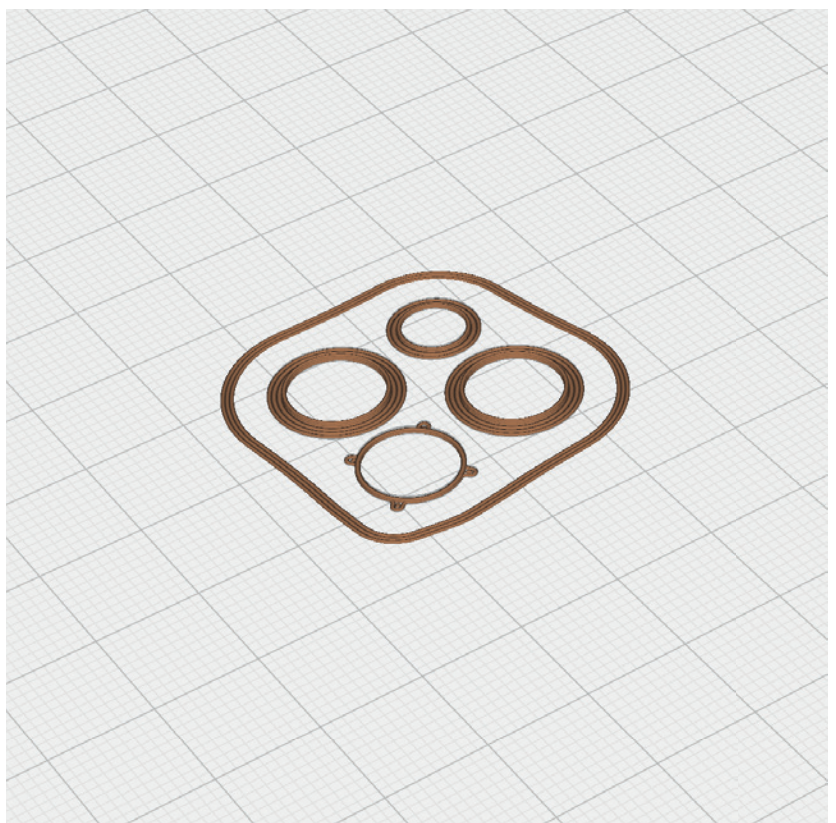

# PROFILE P1\_Fullbody Tough PLA (or PLA)

The following parts must be sliced with the PROFILE P1\_Fullbody.  
Please note the additional settings for the individual parts!

## P1\_Parts\_bl.stl

**MATERIAL** PLA, Weight: ~ 3 g

### **ADDITIONAL SETTINGS**

None required

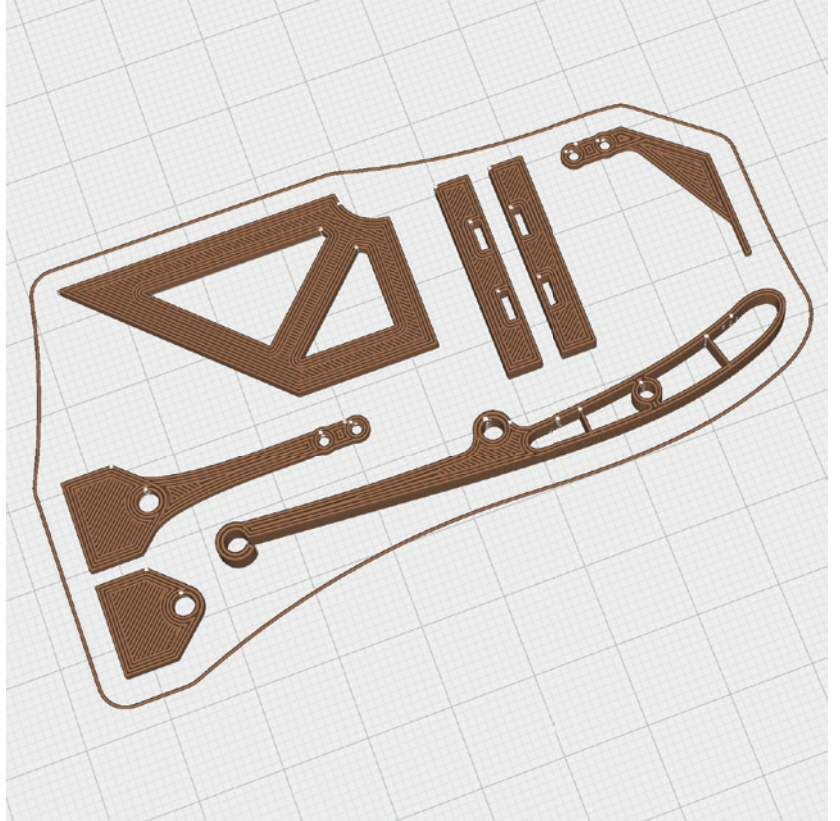

## P1\_Rim template\_bl.stl

**MATERIAL** PLA, Weight: ~ 4 g

### **ADDITIONAL SETTINGS**

None required

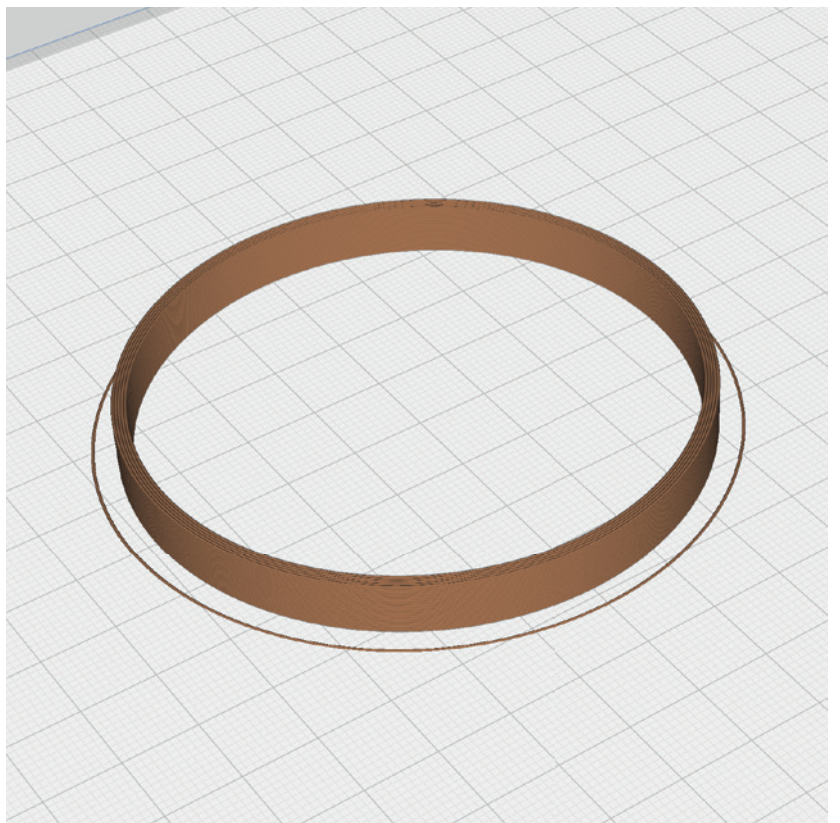

# PROFILE P1\_Fullbody Tough PLA (or PLA)

The following parts must be sliced with the PROFILE P1\_Fullbody.  
Please note the additional settings for the individual parts!

## P1\_Rim\_x4\_bl.stl

**MATERIAL** PLA, Weight: ~ 2 g

### ADDITIONAL SETTINGS

None required

**TIP** use gray or silver filament

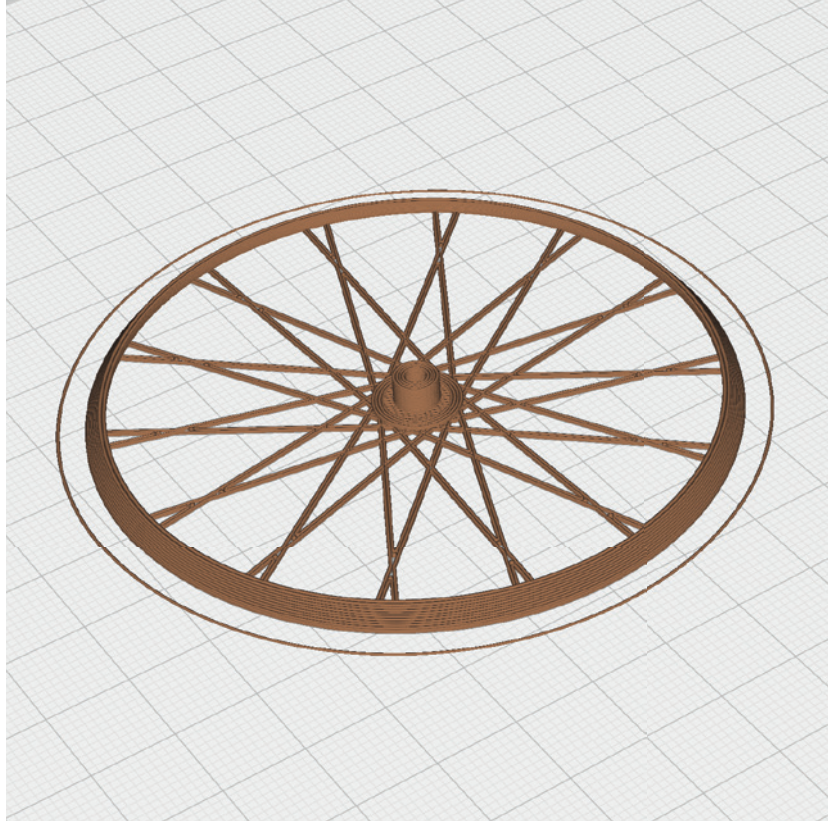

## P1\_Rudder\_bl.stl

**MATERIAL** PLA, Weight: ~ 2 g

### ADDITIONAL SETTINGS

None required

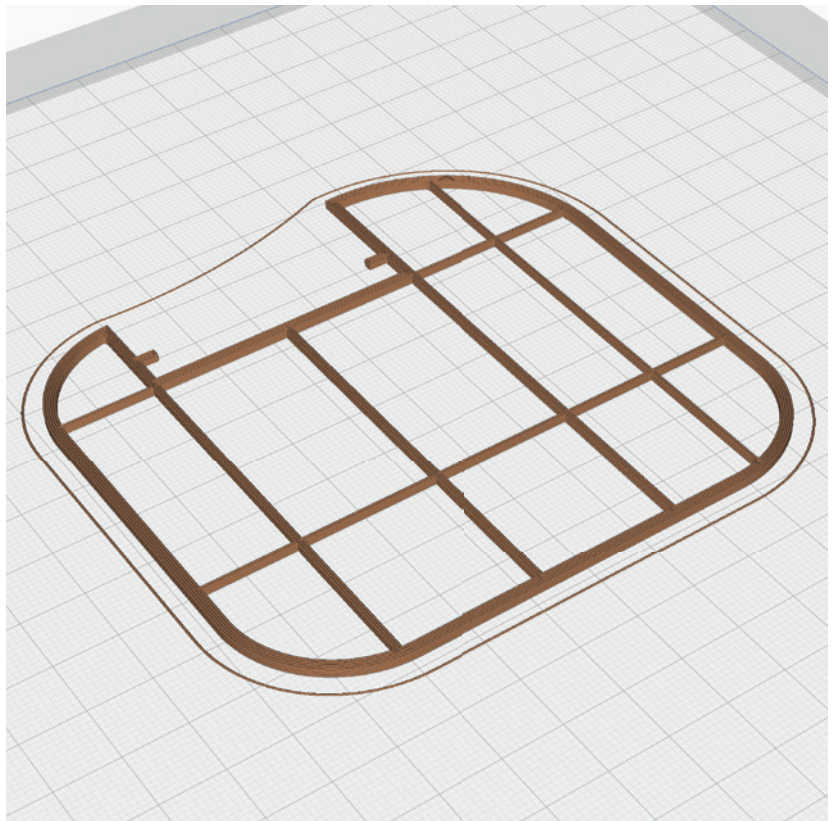

# PROFILE P1\_Fullbody Tough PLA (or PLA)

The following parts must be sliced with the PROFILE P1\_Fullbody.  
Please note the additional settings for the individual parts!

P1\_Wing 1-L\_bl.stl  
P1\_Wing 1-R\_bl.stl

**MATERIAL** PLA, Weight: ~ 14 g

**ADDITIONAL SETTINGS**

None required

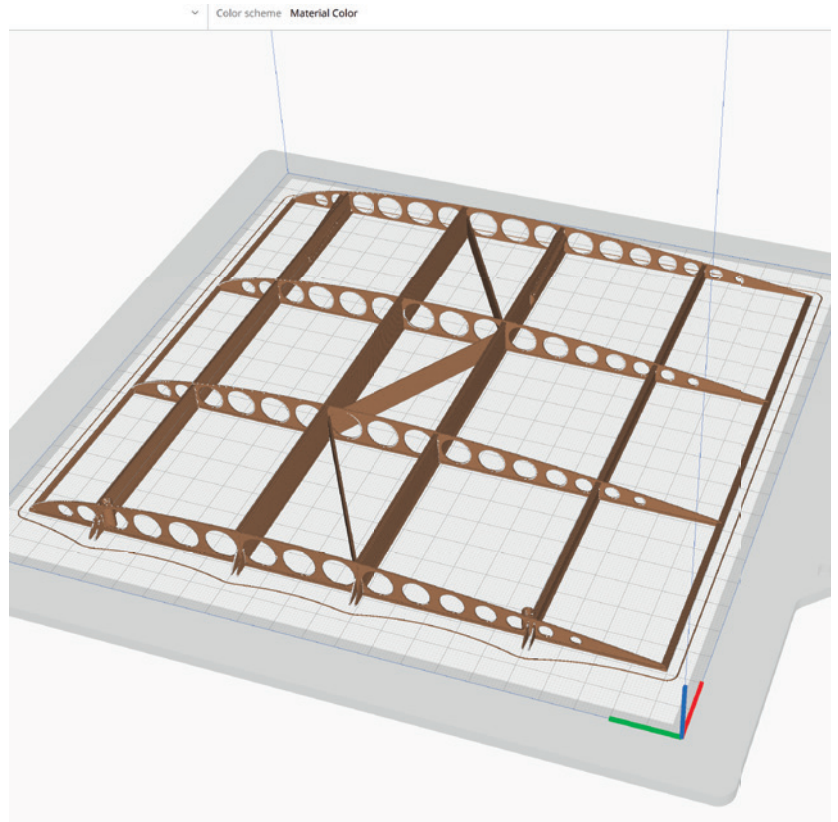

P1\_Wing 2-L\_bl.stl  
P1\_Wing 2-R\_bl.stl

**MATERIAL** PLA, Weight: ~ 8 g

**ADDITIONAL SETTINGS**

None required

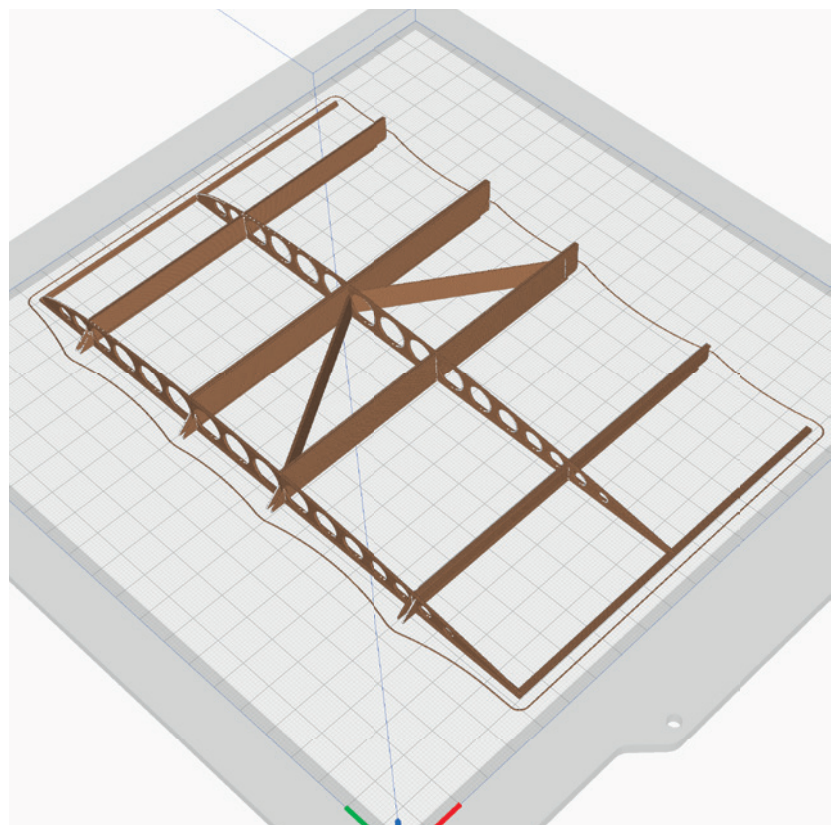

# PROFILE P1\_Fullbody Tough PLA (or PLA)

The following parts must be sliced with the PROFILE P1\_Fullbody.  
Please note the additional settings for the individual parts!

P1\_Wing 3-L\_bl.stl  
P1\_Wing 3-R\_bl.stl

**MATERIAL** PLA, Weight: ~ 8 g

**ADDITIONAL SETTINGS**

None required

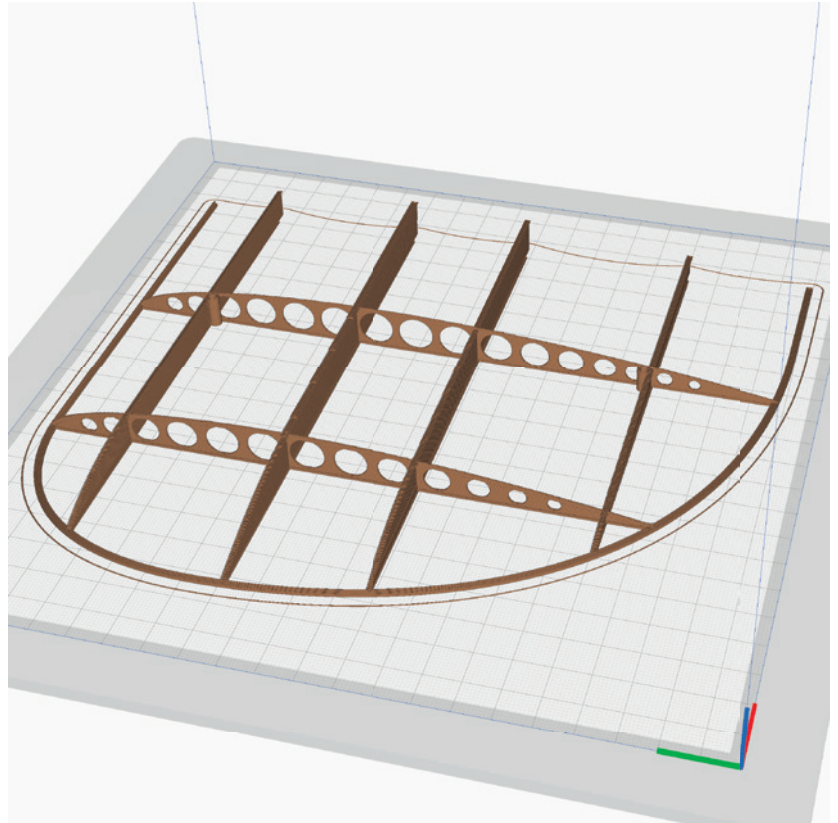

# PROFILE P2\_Hollowbody Tough PLA (or PLA)

The following parts must be sliced with the PROFILE P2\_Hollowbody.  
Please note the additional settings for the individual parts!

## P2\_Hood\_bl.stl

**MATERIAL** PLA, Weight: ~ 12 g

### ADDITIONAL SETTINGS

None required

**TIP** Paint this part with black acrylic paint (looks better than black PLA)

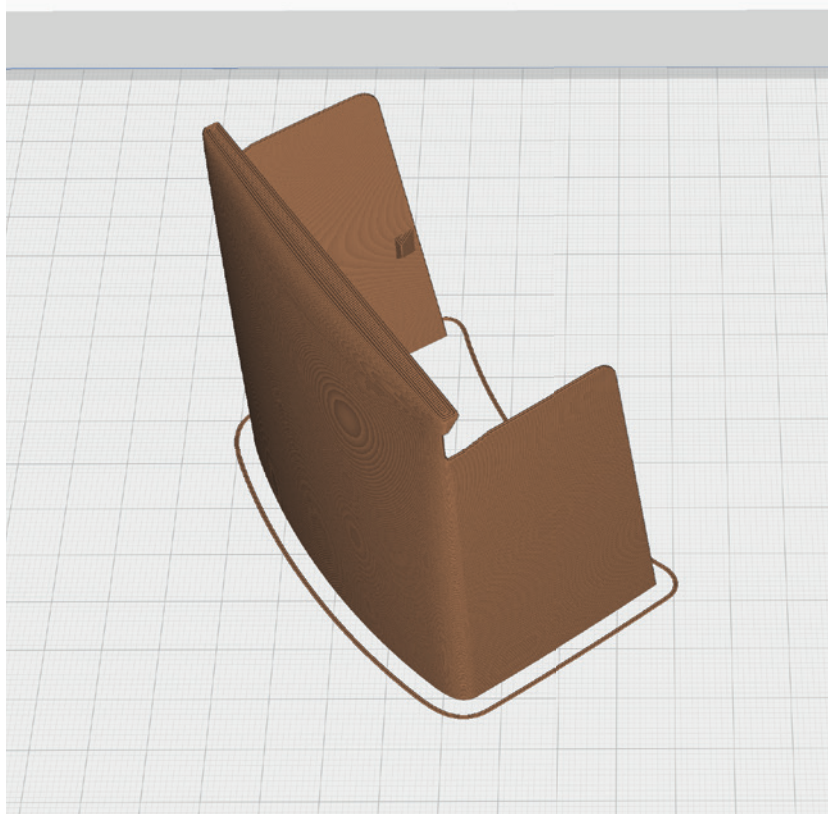

## P2\_Instrument panel\_bl.stl

**MATERIAL** PLA, Weight: ~ 5 g

### ADDITIONAL SETTINGS

- Wall Line Count: 1
- Bottom Layers: 1

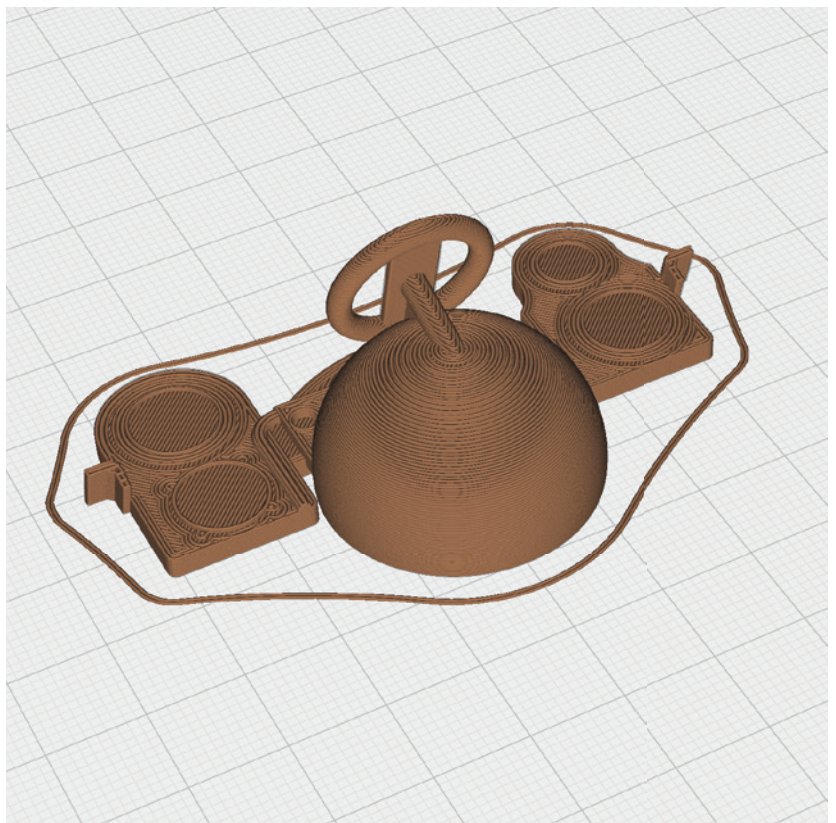

# PROFILE P2\_Hollowbody Tough PLA (or PLA)

The following parts must be sliced with the PROFILE P2\_Hollowbody.  
Please note the additional settings for the individual parts!

## P2\_Motor\_bl.stl

**MATERIAL** PLA, Weight: ~ 6 g

### **ADDITIONAL SETTINGS**

- Wall Line Count: 1
- Bottom Layers: 0

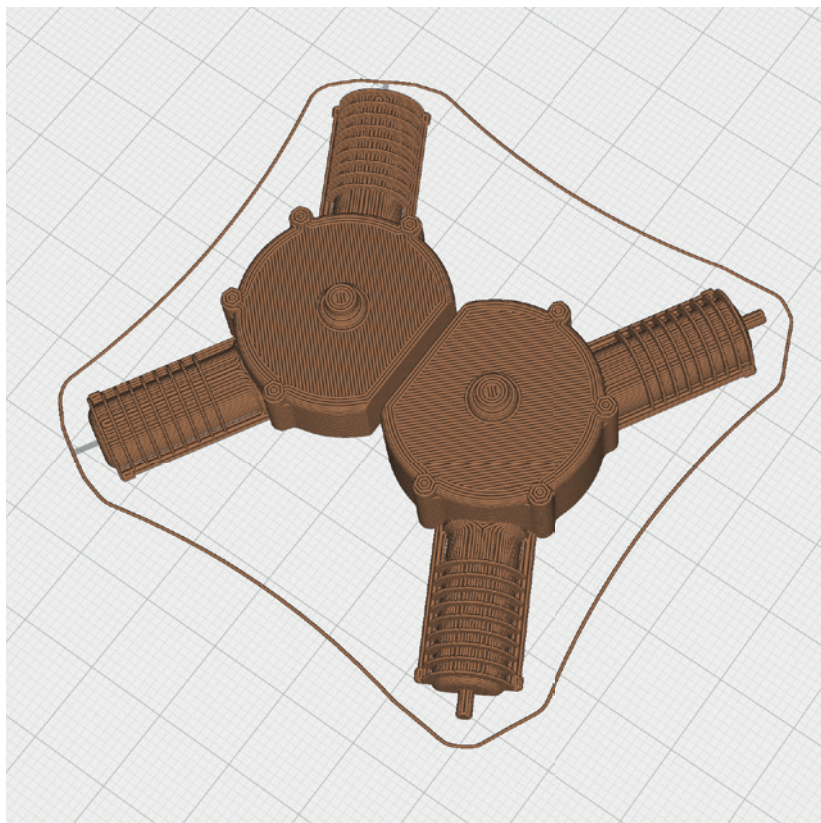

# PROFILE P4\_Flex LW TPU VarioShore

The following parts must be sliced with the PROFILE P4\_Flex.  
**Please note the additional settings for the individual parts!**

## P4\_Tire\_x2\_bl.stl

**MATERIAL** TPU VarioShore, Weight: ~ 2 g

### **ADDITIONAL SETTINGS**

- Infill Density: 100 %
- Flow: 60 % (VarioShore)
- Print it twice

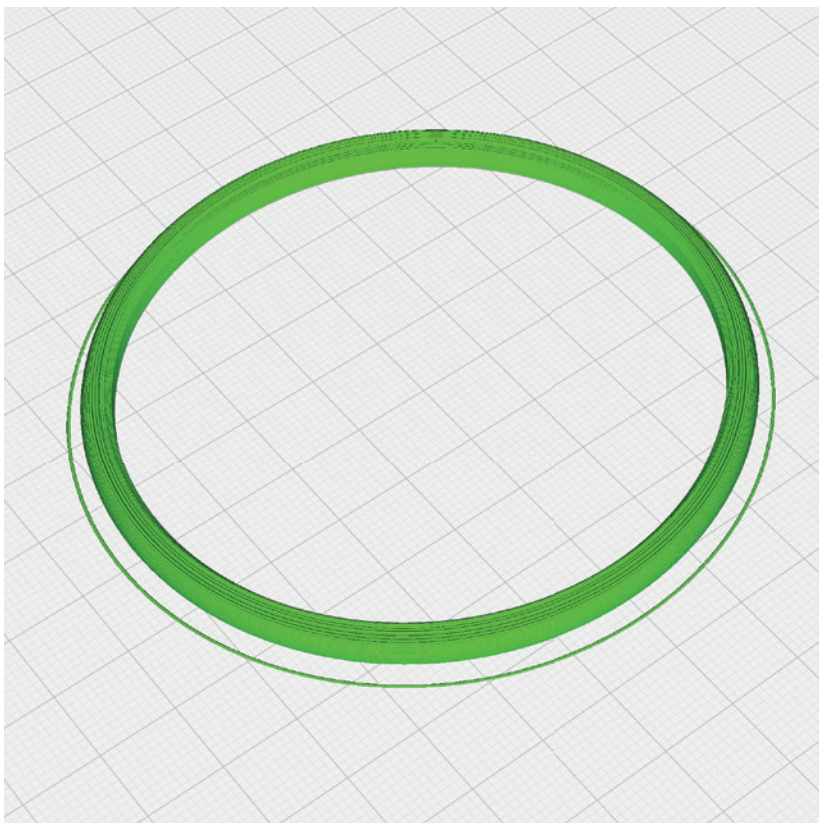

# Wings assembly

Mount the wings on a flat table or surface. Place something to protect the glued areas, for example the backing paper of an adhesive film.



P1\_Wing 1-L\_bl.stl

P1\_Wing 2-L\_bl.stl

P1\_Wing 3-L\_bl.stl

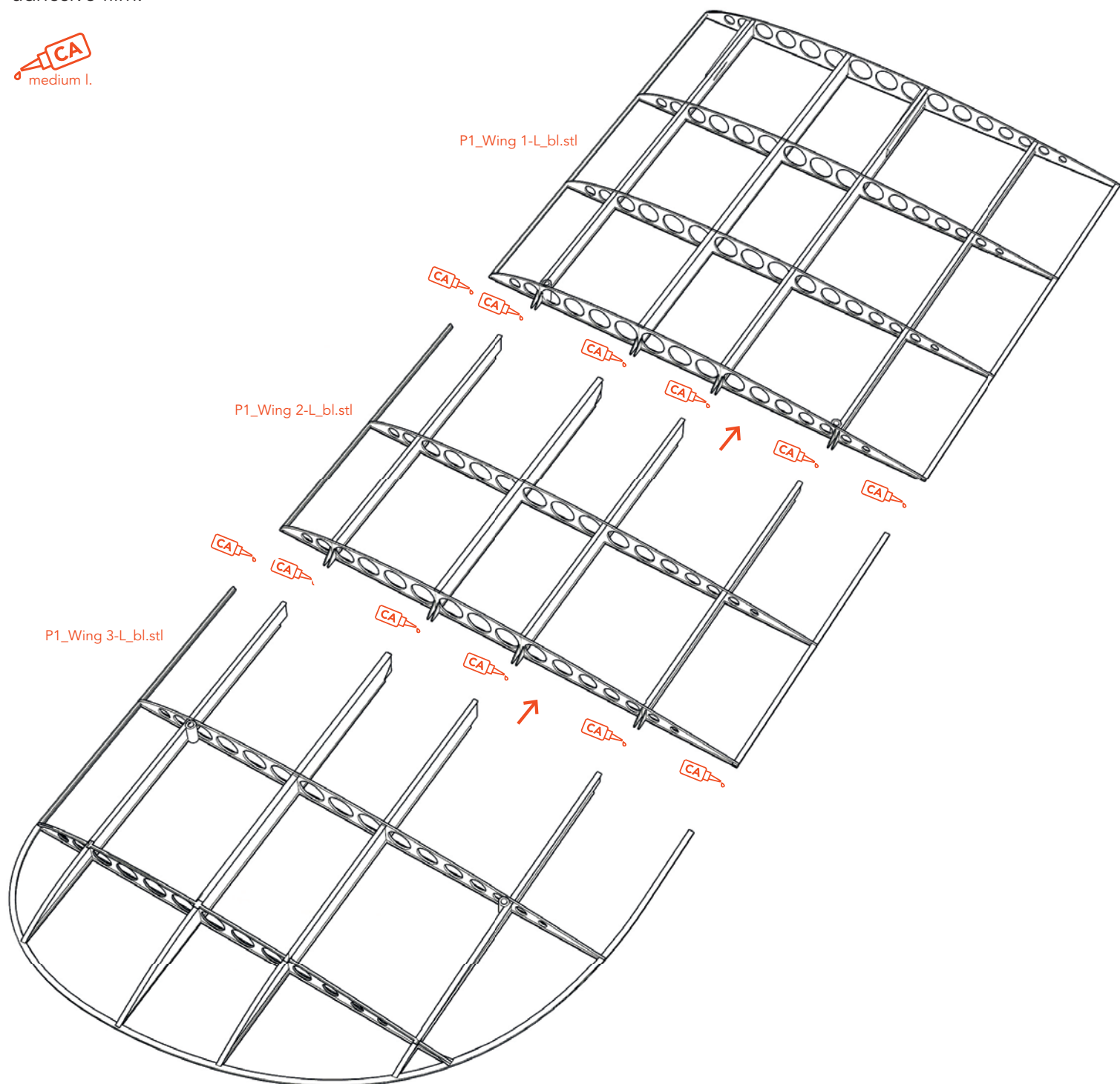

# Covering the wings

Tape a piece of Parchment or tissue paper to a flat surface without wrinkles.

Dilute the wood glue with a little (little) water and apply it like paint with a small brush on the underside of the wings.

Place the wing on the paper and weigh it down so that the entire adhesive surface lies flat on the paper.

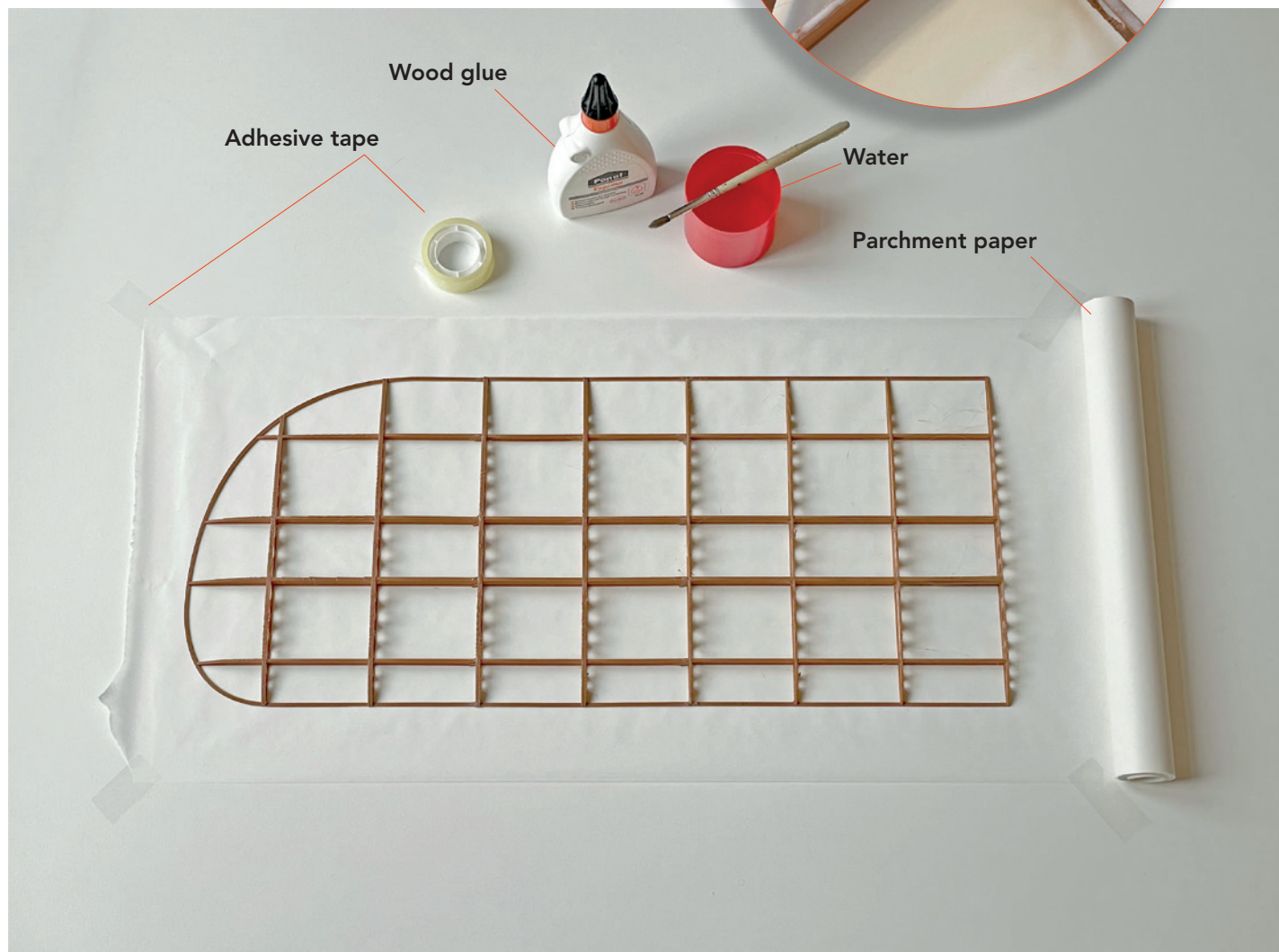
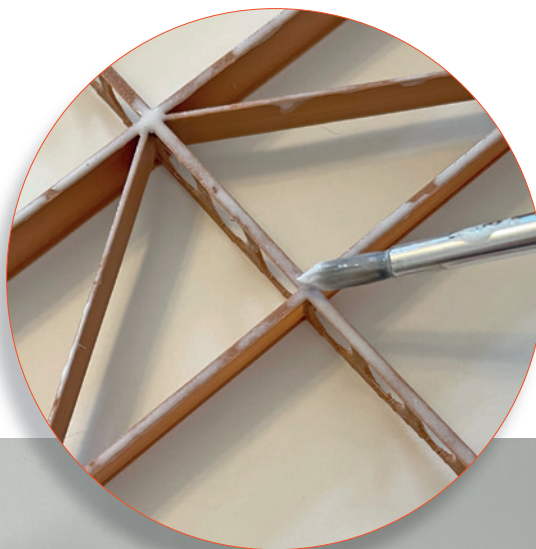

When the glue is dry, cut the paper with some overhang (5 mm) along the wing edge and fold it on the bottom side and glue it with the help of the brush.

The next step is to glue a strip of paper to the wingtips, see picture.

Finally, cover the top side.



# Covering the wings

Now spray the entire wing with a fine water sprayer so that the paper is slightly damp (not wet).

To dry, the wing must lie absolutely flat and be well ventilated at the top and bottom.

**Weigh it down at the top in several places so that it cannot warp during drying!**

During drying, the paper stretches a little and becomes absolutely smooth. Test this process beforehand with the paper you are using to be sure (rudder).

**IMPORTANT** If the wing is twisted after drying, the procedure must be repeated (It is enough to moisten it only on the top side). The wing must be as flat as possible on the underside.

**TIP** You can also use other methods and materials to cover the wings, there are many tutorials on youtube.

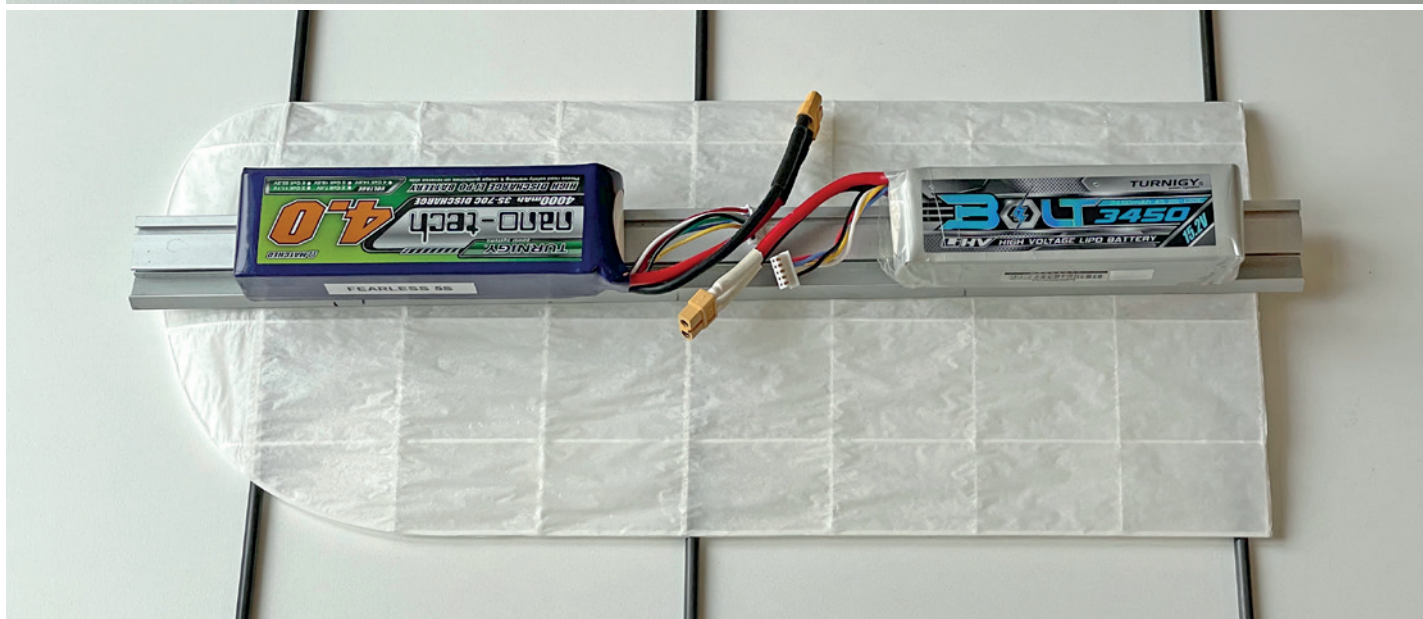

# Tailplane assembly

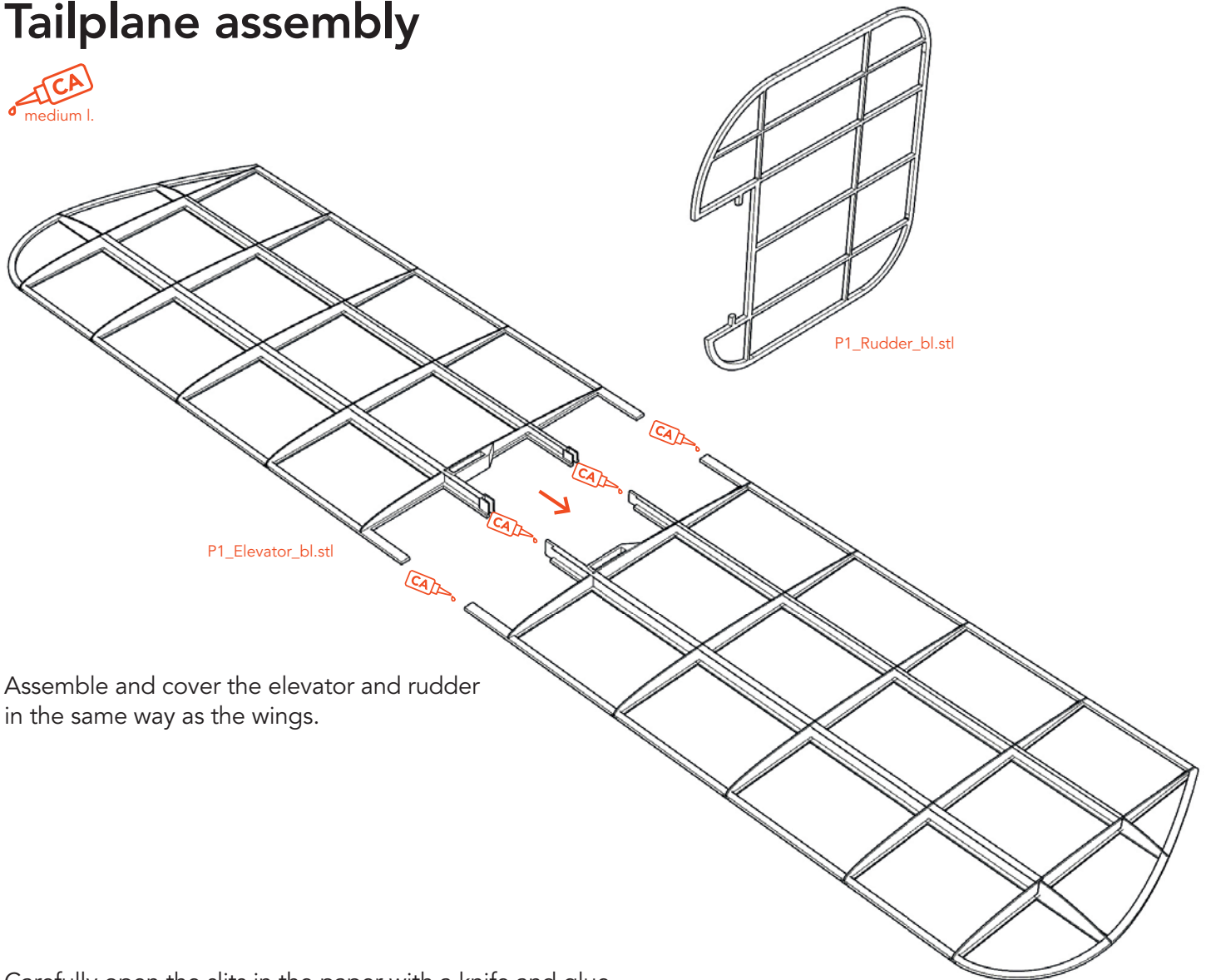

Assemble and cover the elevator and rudder in the same way as the wings.

Carefully open the slits in the paper with a knife and glue the control horns in place as shown.

**With the help of a 2mm carbon rod, make sure that the horns are glued in parallel!**

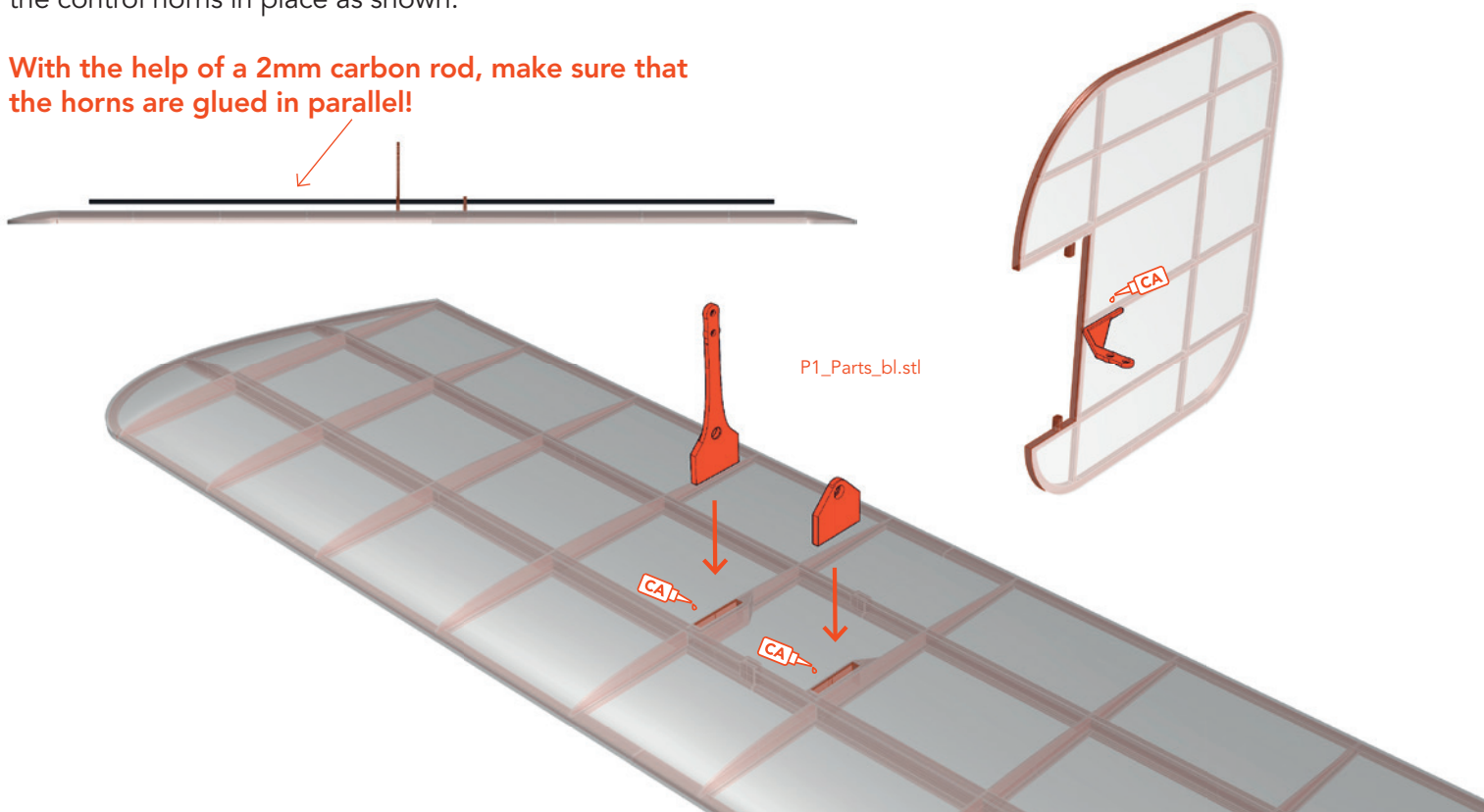

# Fuselage assembly

Bend the eyelets for the linkage 90° inwards and fix the bending point with a drop of viscous CA glue.



P1\_Grid 2 side\_bl.stl  
P1\_Grid 3 side\_bl.stl  
P1\_Grid 4 side\_x2\_bl.stl

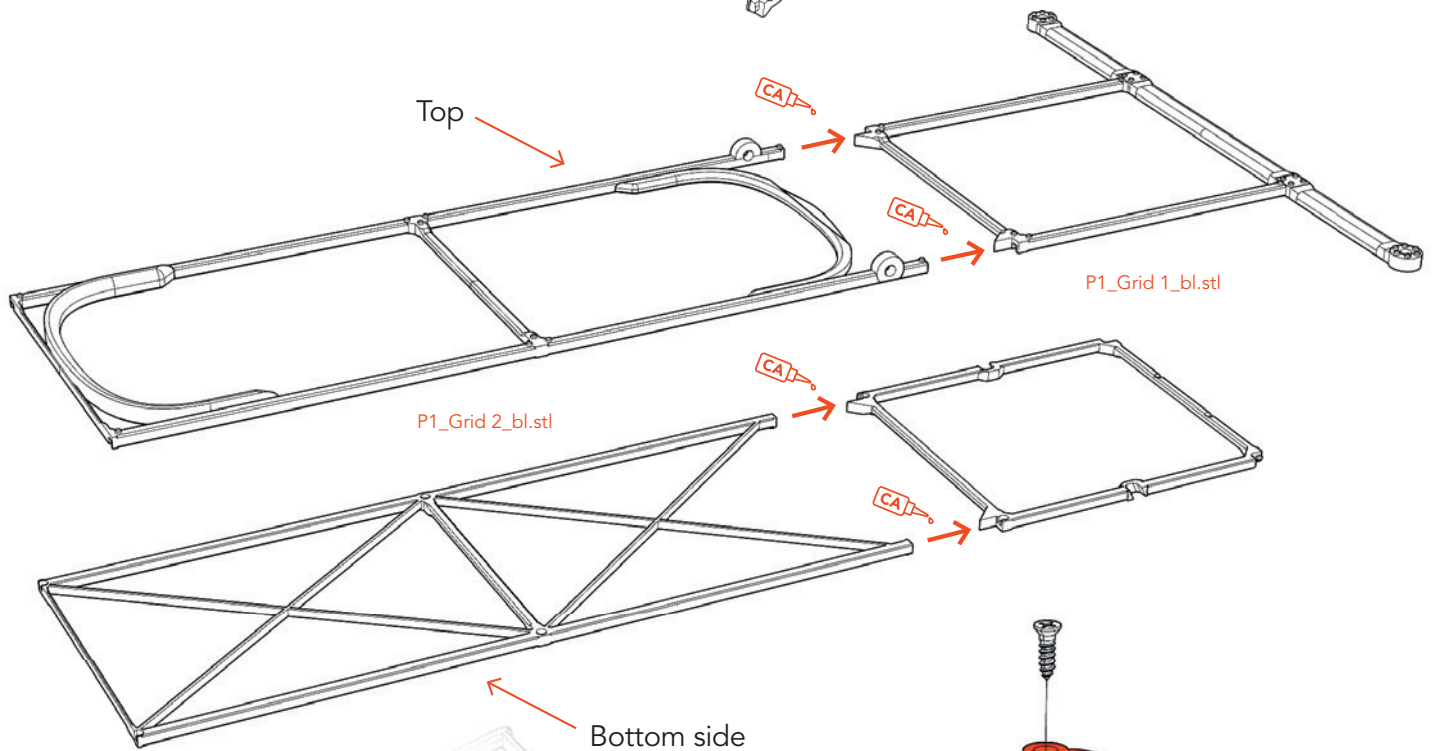
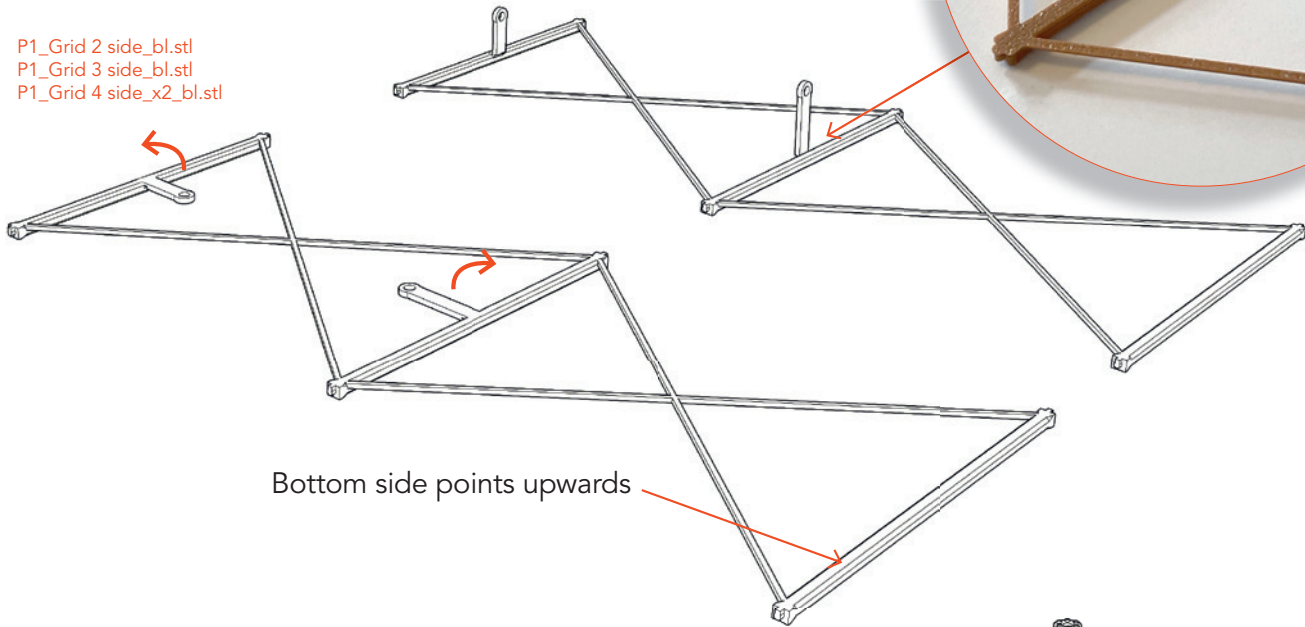

Loosely tighten the lever for changing the **angle of incidence** with a small sheet metal screw so that the lever can still be moved.

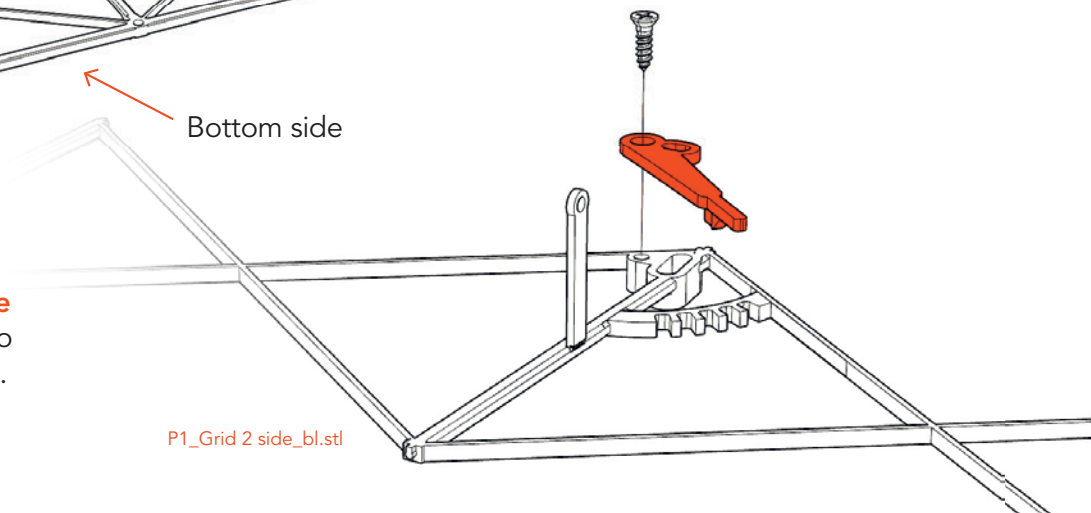

# Fuselage assembly

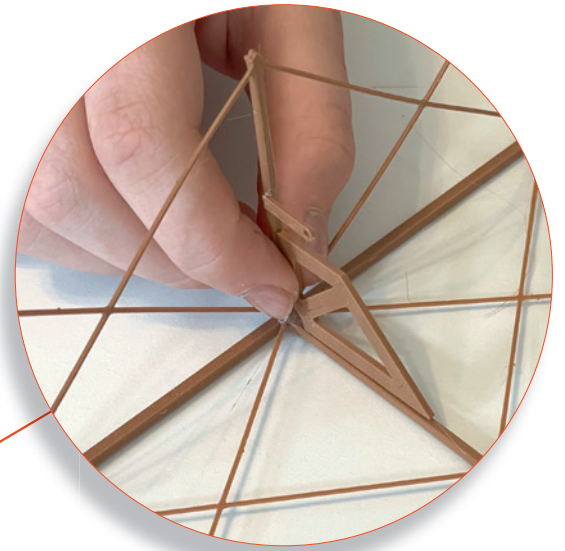
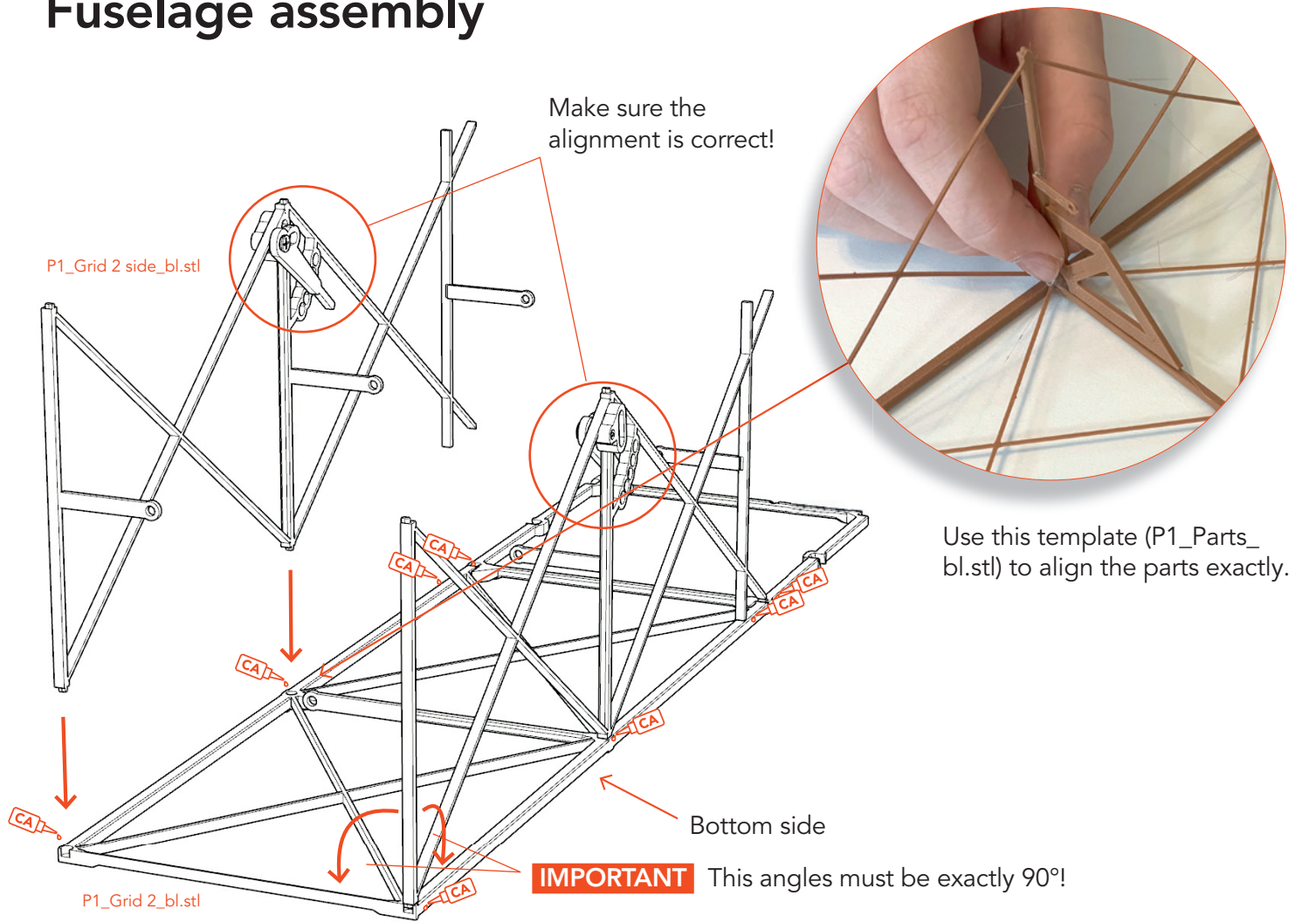

Use this template (P1\_Parts\_bl.stl) to align the parts exactly.

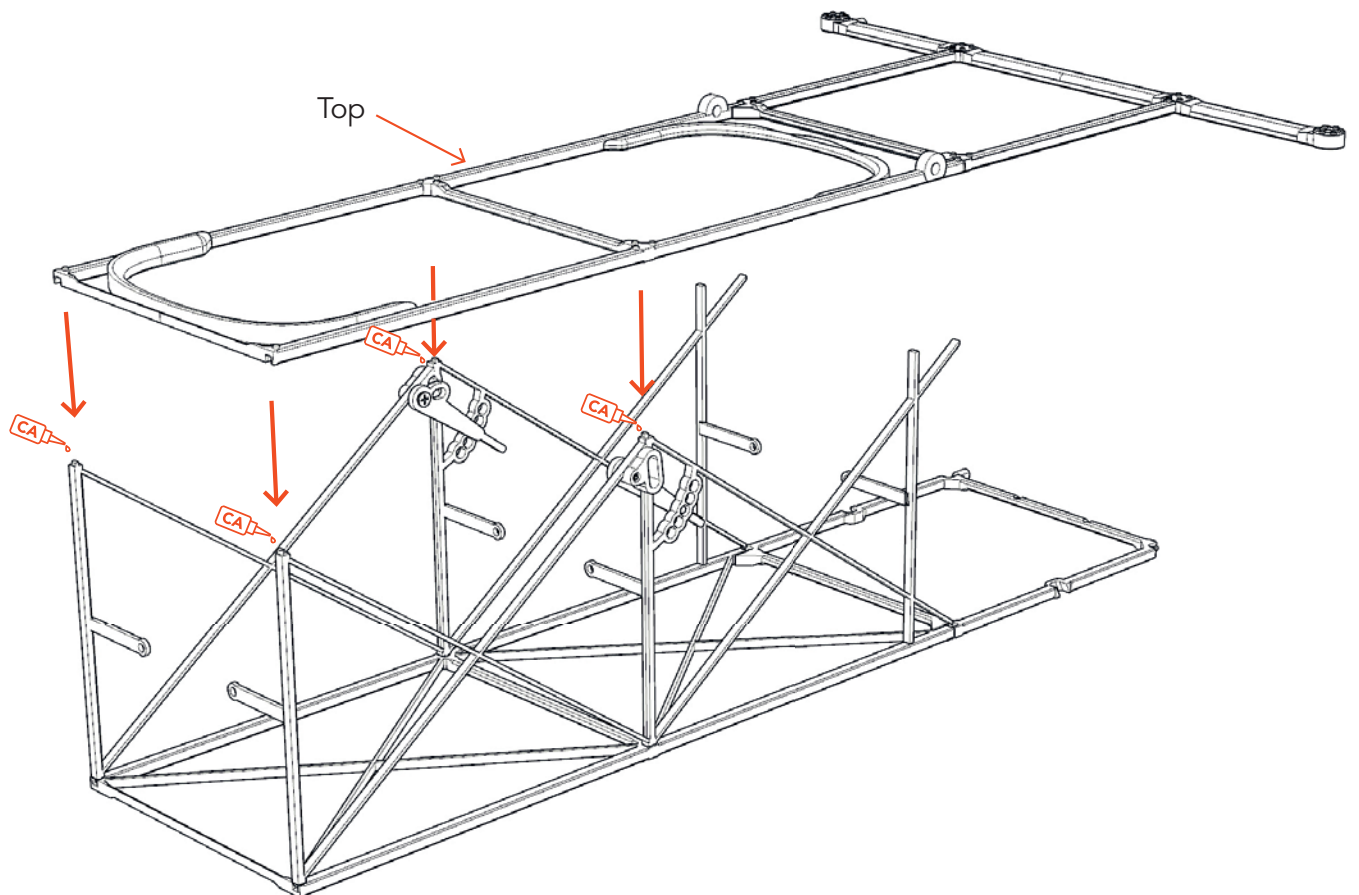

# Fuselage assembly

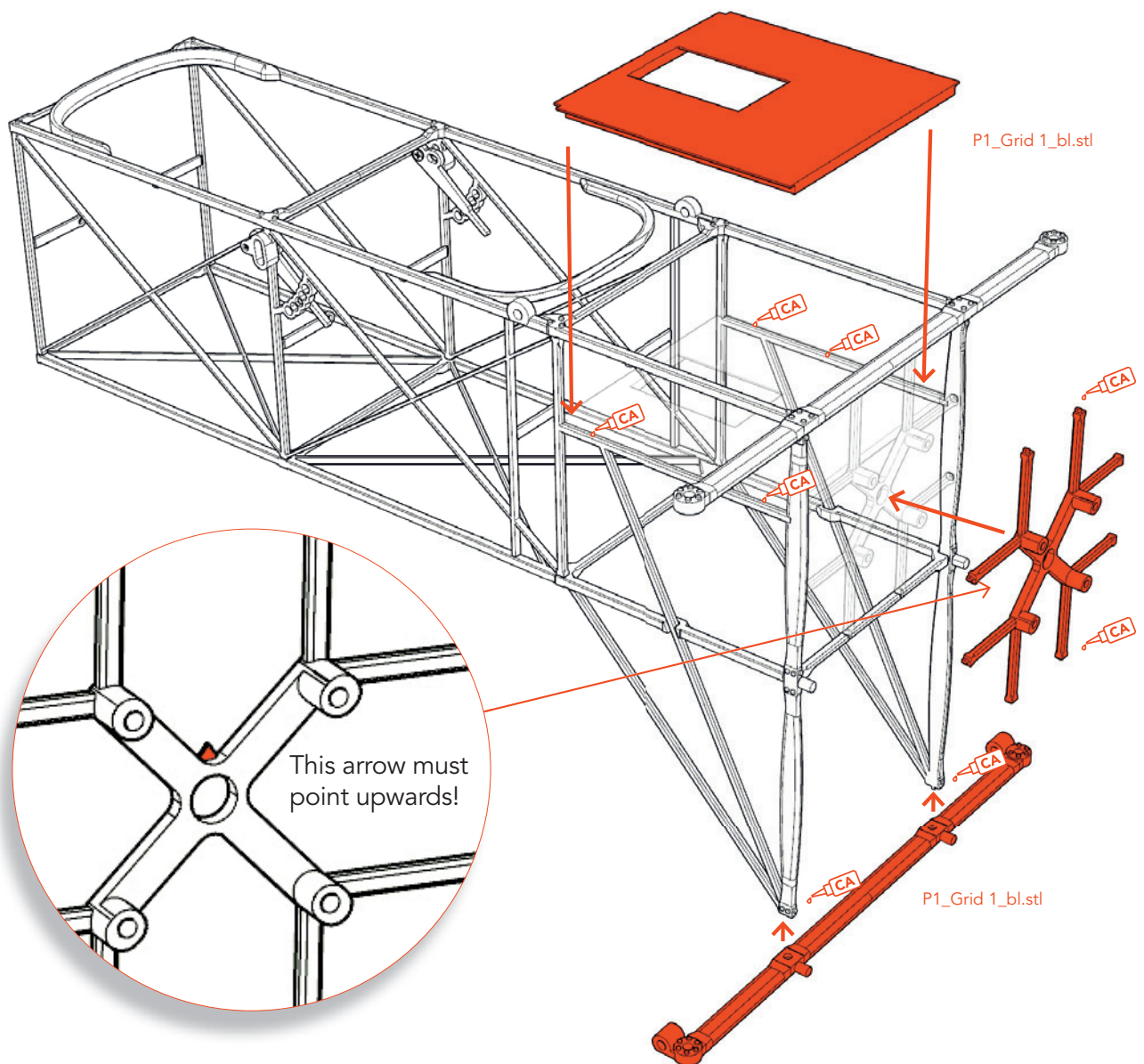
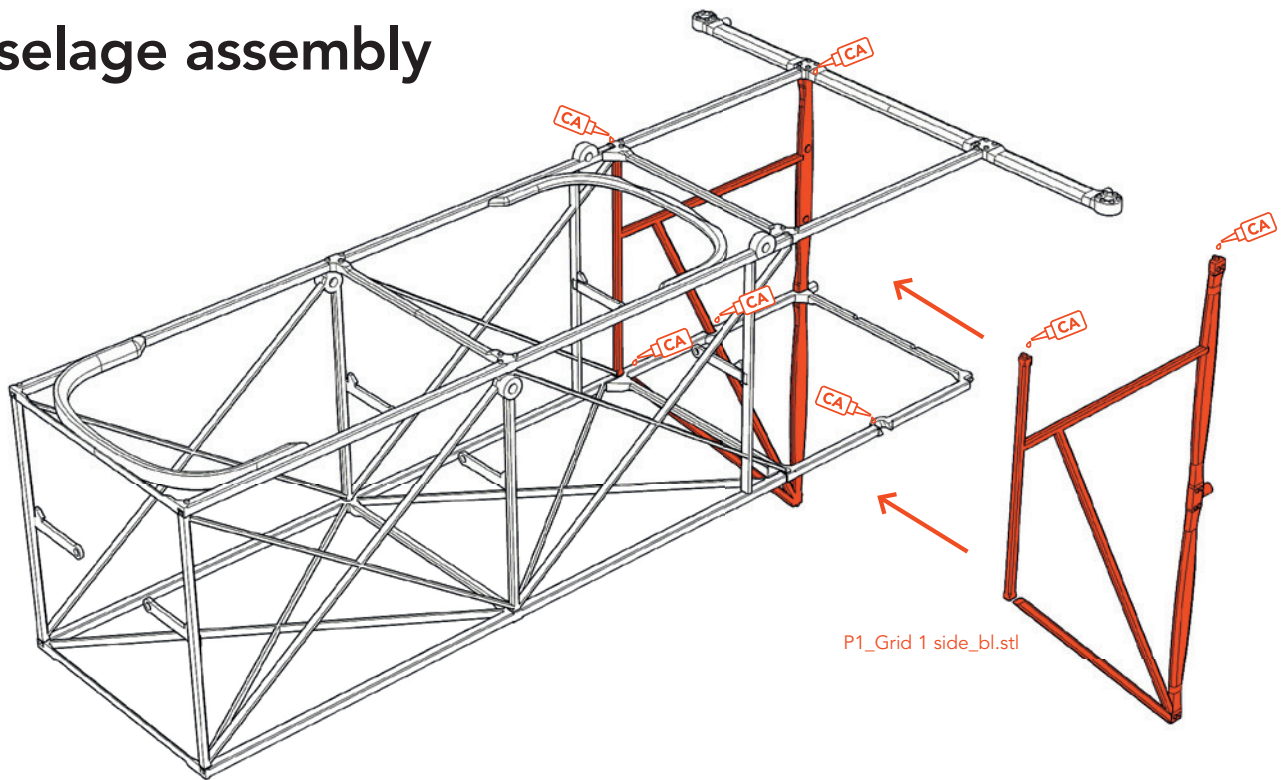

# Fuselage assembly

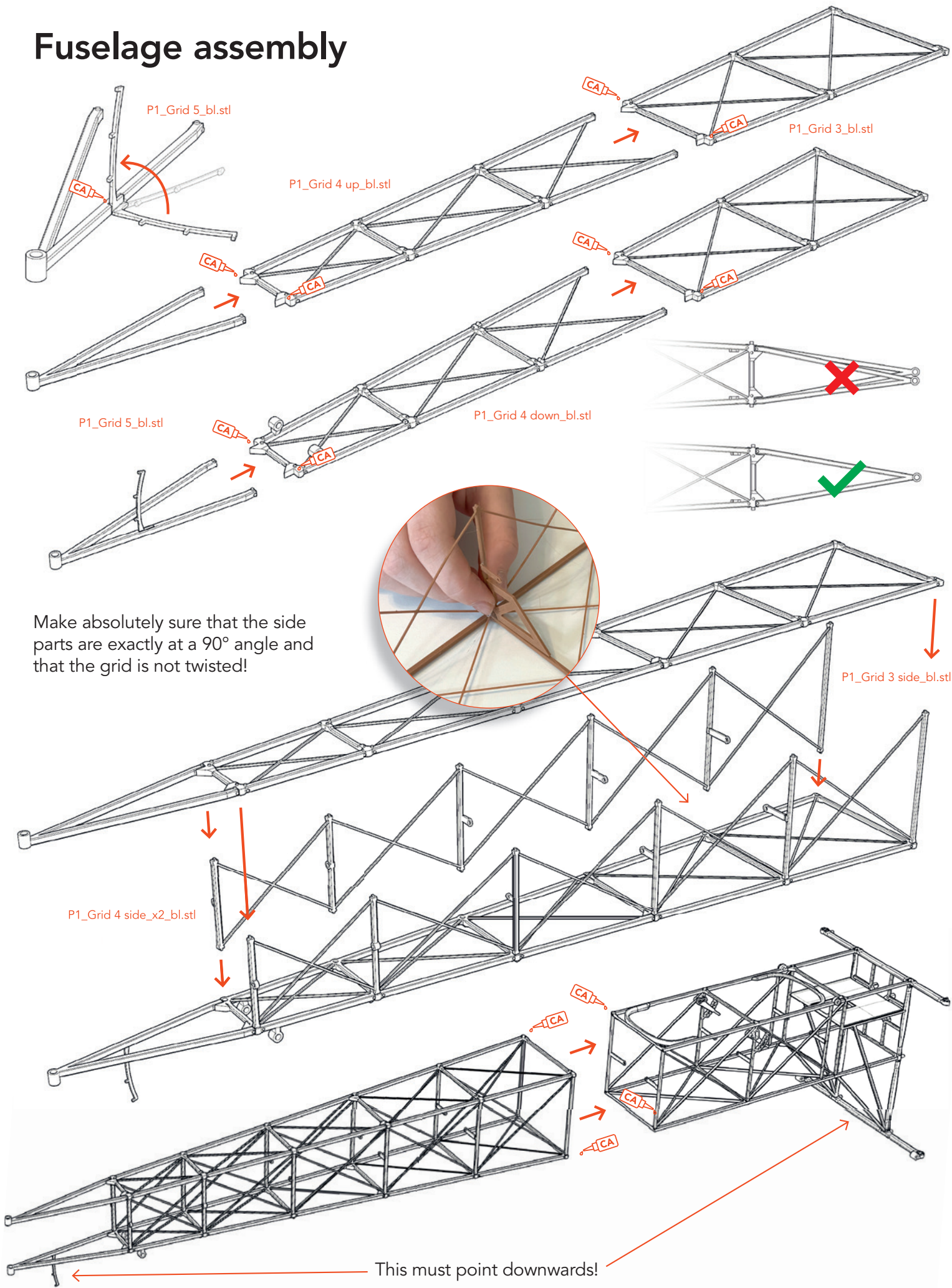

Make absolutely sure that the side parts are exactly at a 90° angle and that the grid is not twisted!

This must point downwards!

# Gear assembly

Apply glue to the lower half of the rim and place it on a flat surface. Then place the tire and the upper rim half on top and press down firmly with the help of the **rim template** until the glue holds. The spokes automatically get tension because the inner axle is higher than the wheel width.

Rotate the rims before gluing as shown here.

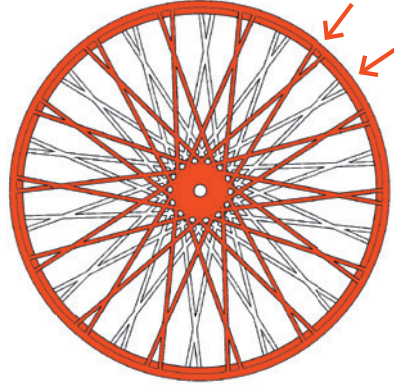

P1\_Rim\_template\_bl.stl

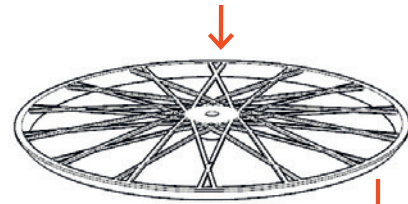

P4\_Tire\_x2\_bl.stl

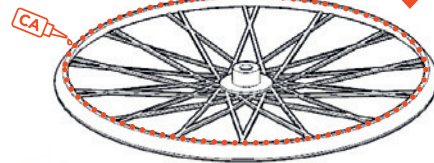

P1\_Rim\_x4\_bl.stl

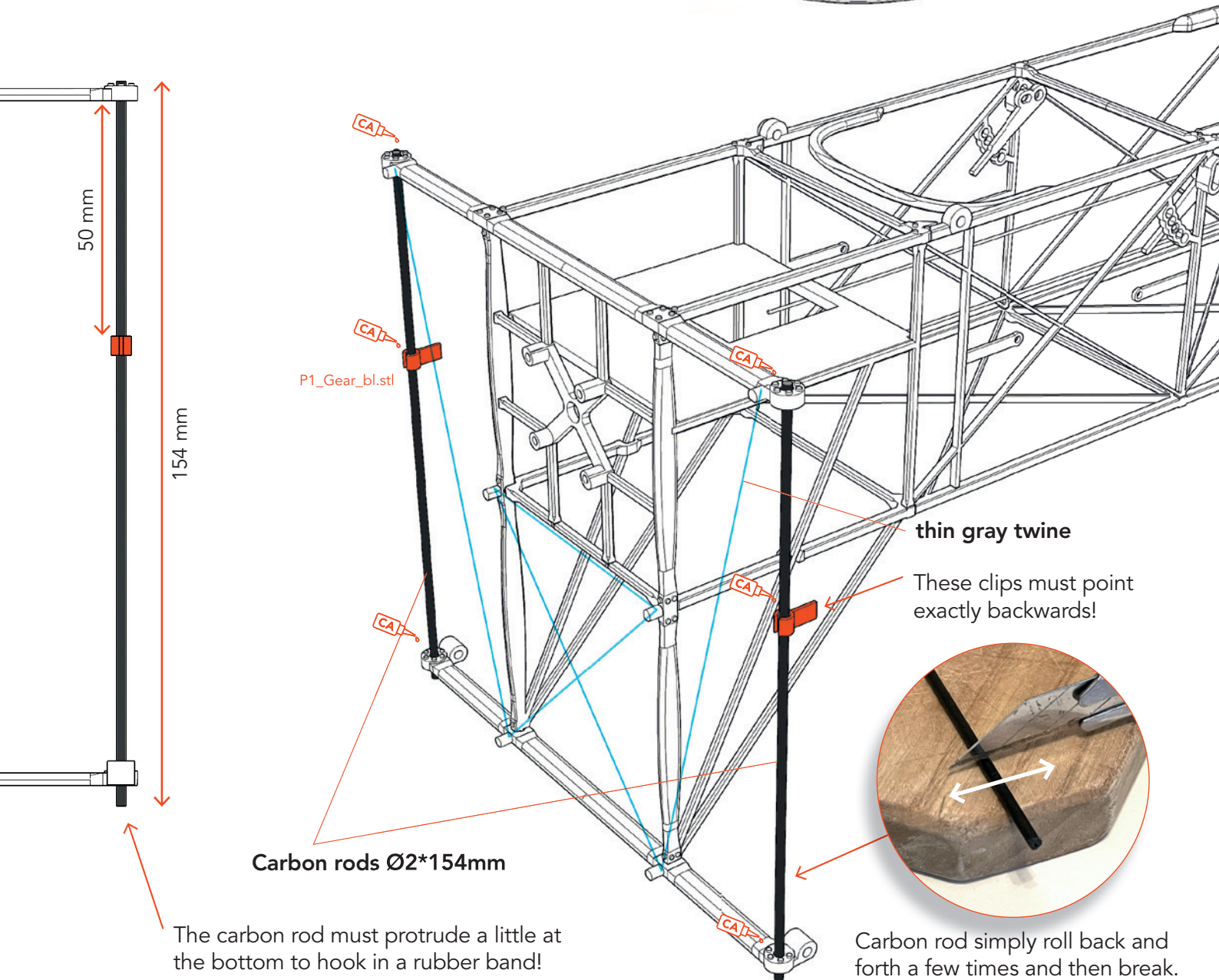

# Gear assembly

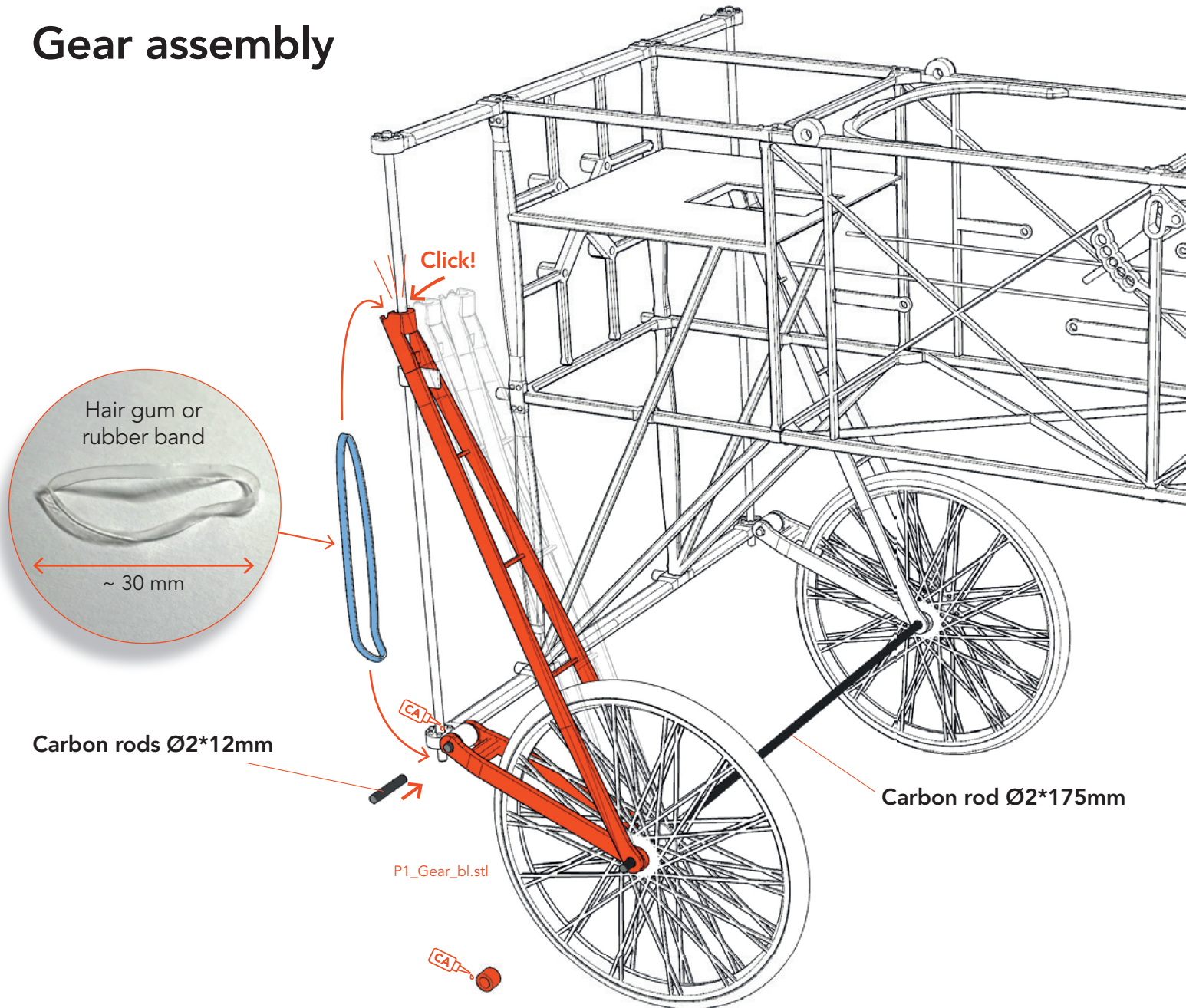

Make sure that these joints must be very smooth!

The tension of the rubber band should be just strong enough so that the gear does not sink in by itself. If the gear is very softly sprung, the landings will be super soft and like original.

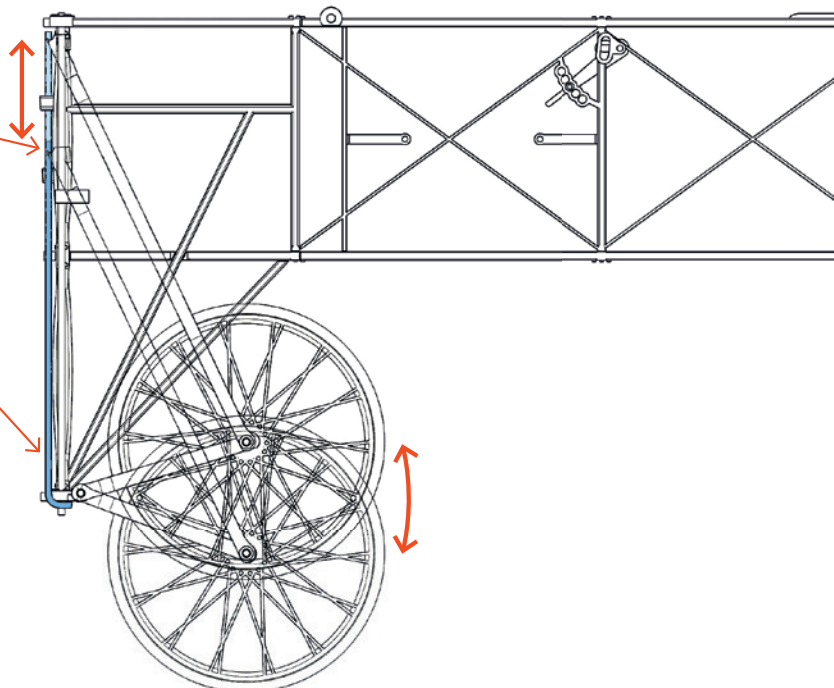

# Spring loaded tail spur

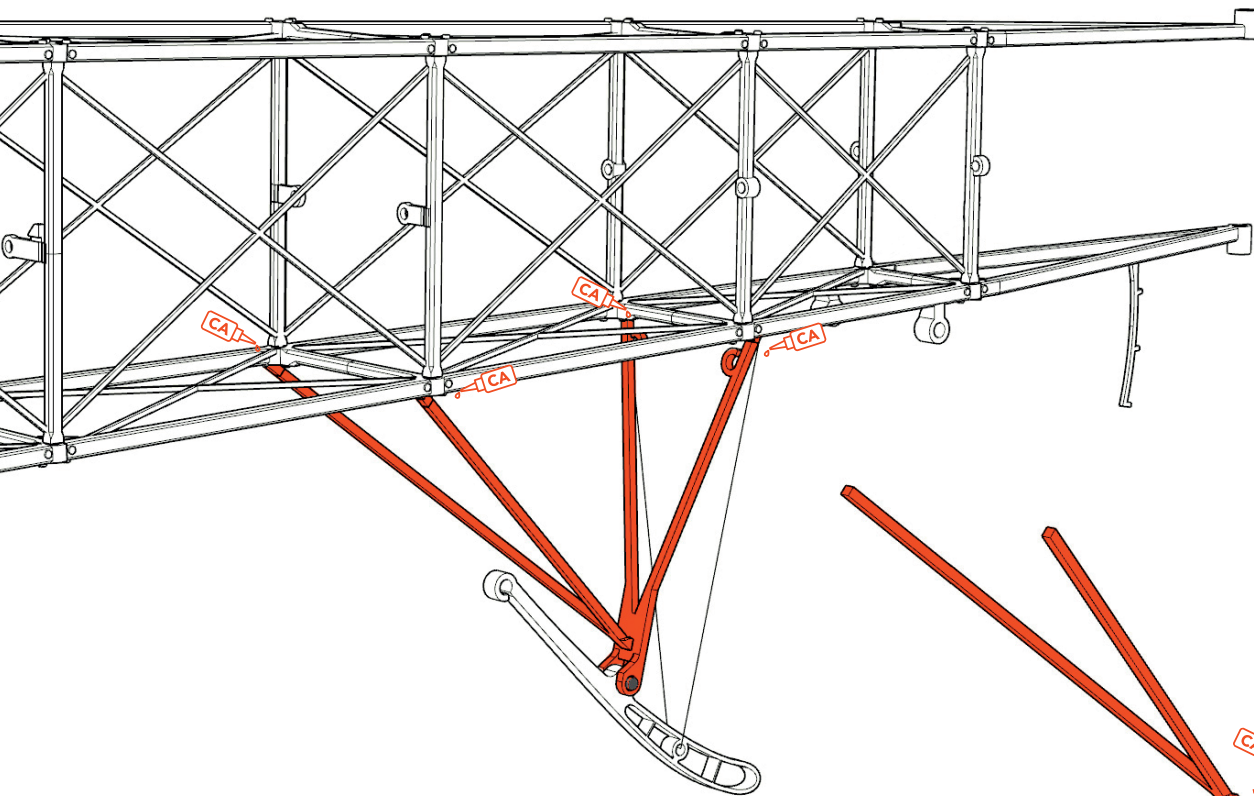

Adjust the twine so that the tail spur points approximately 45 down.

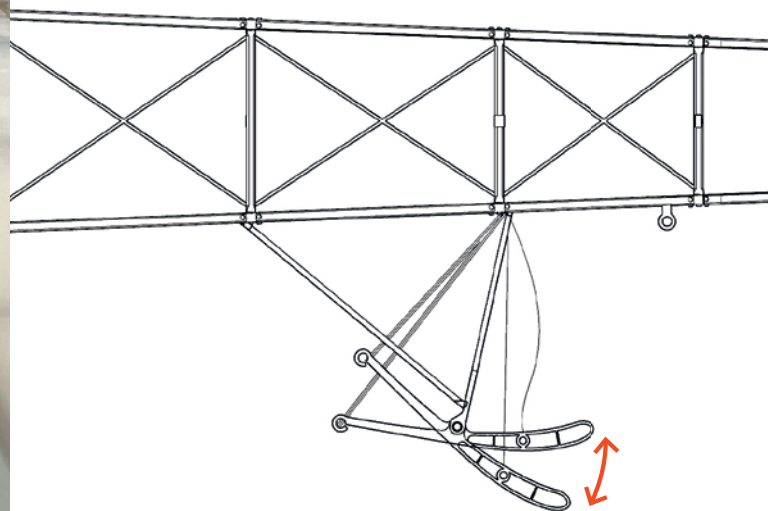
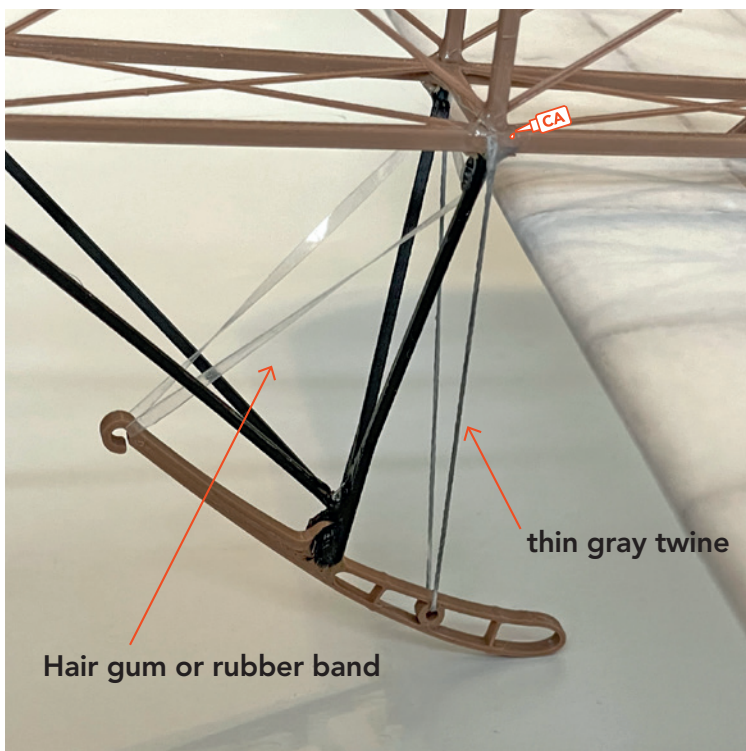
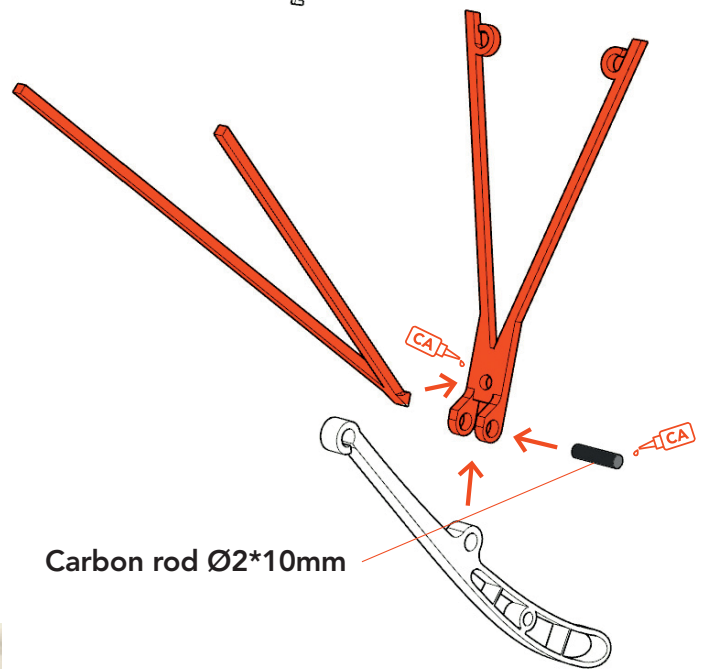

# Tail plane assembly

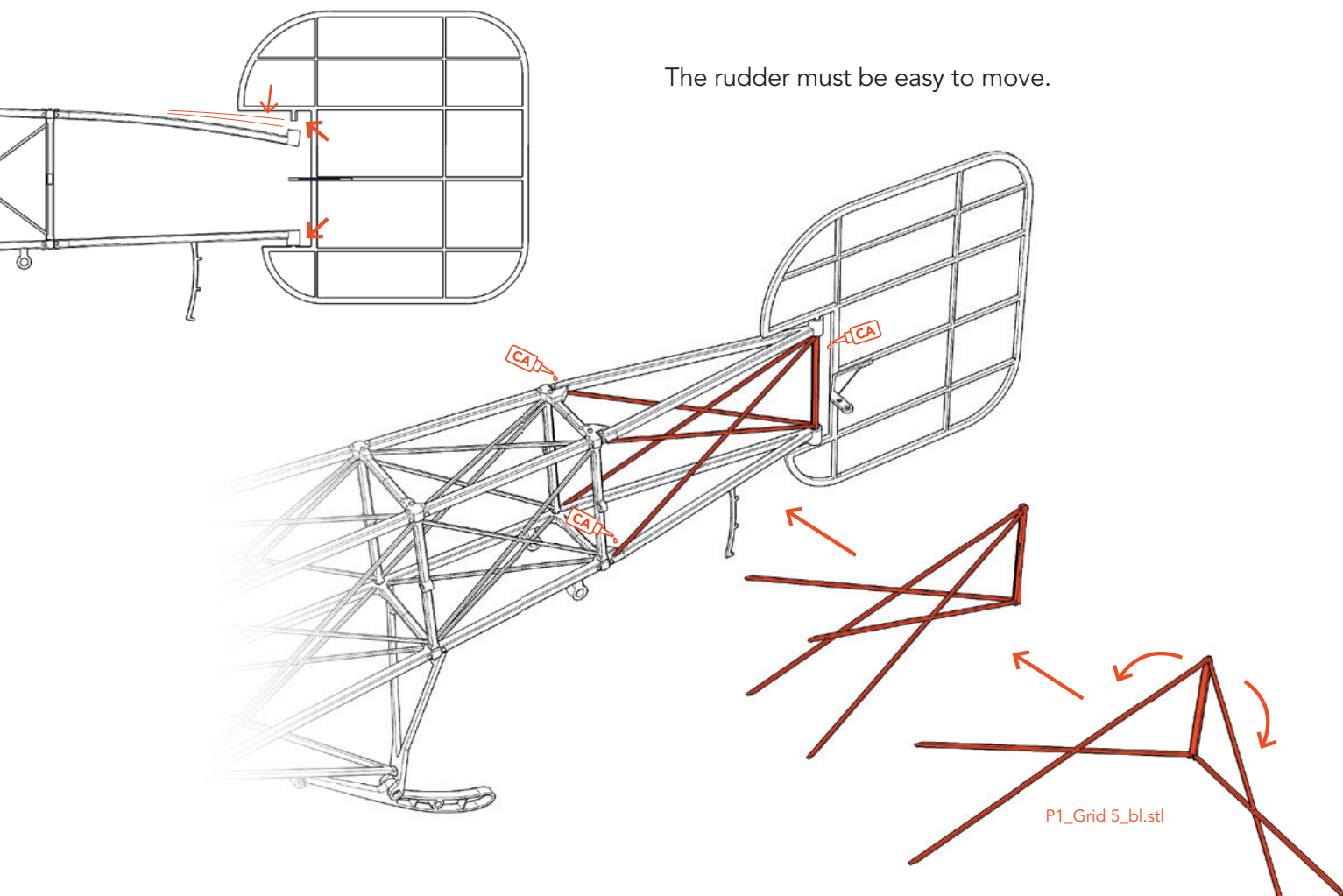

The rudder must be easy to move.

Fix the carbon rod on the outside with a drop of glue. **No glue may get into the joint!**

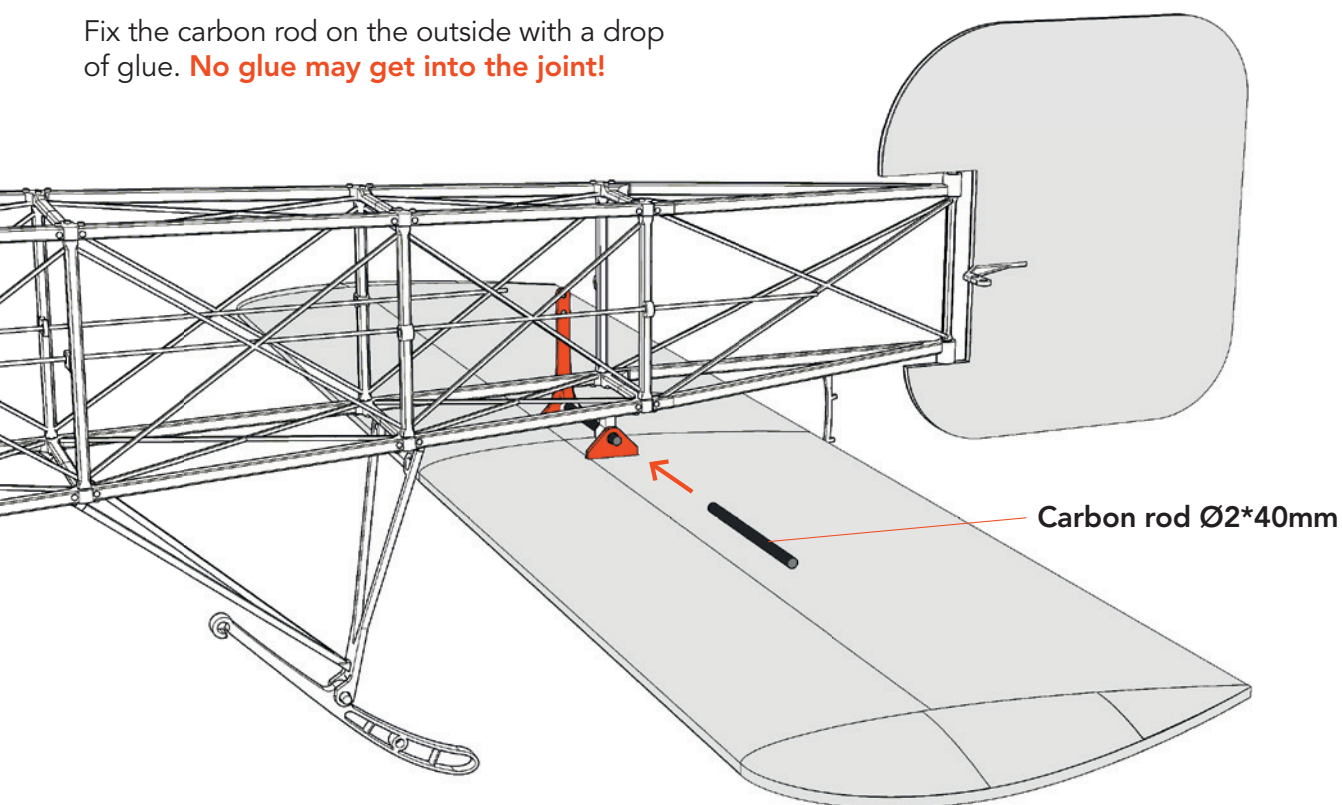

# Servo mount

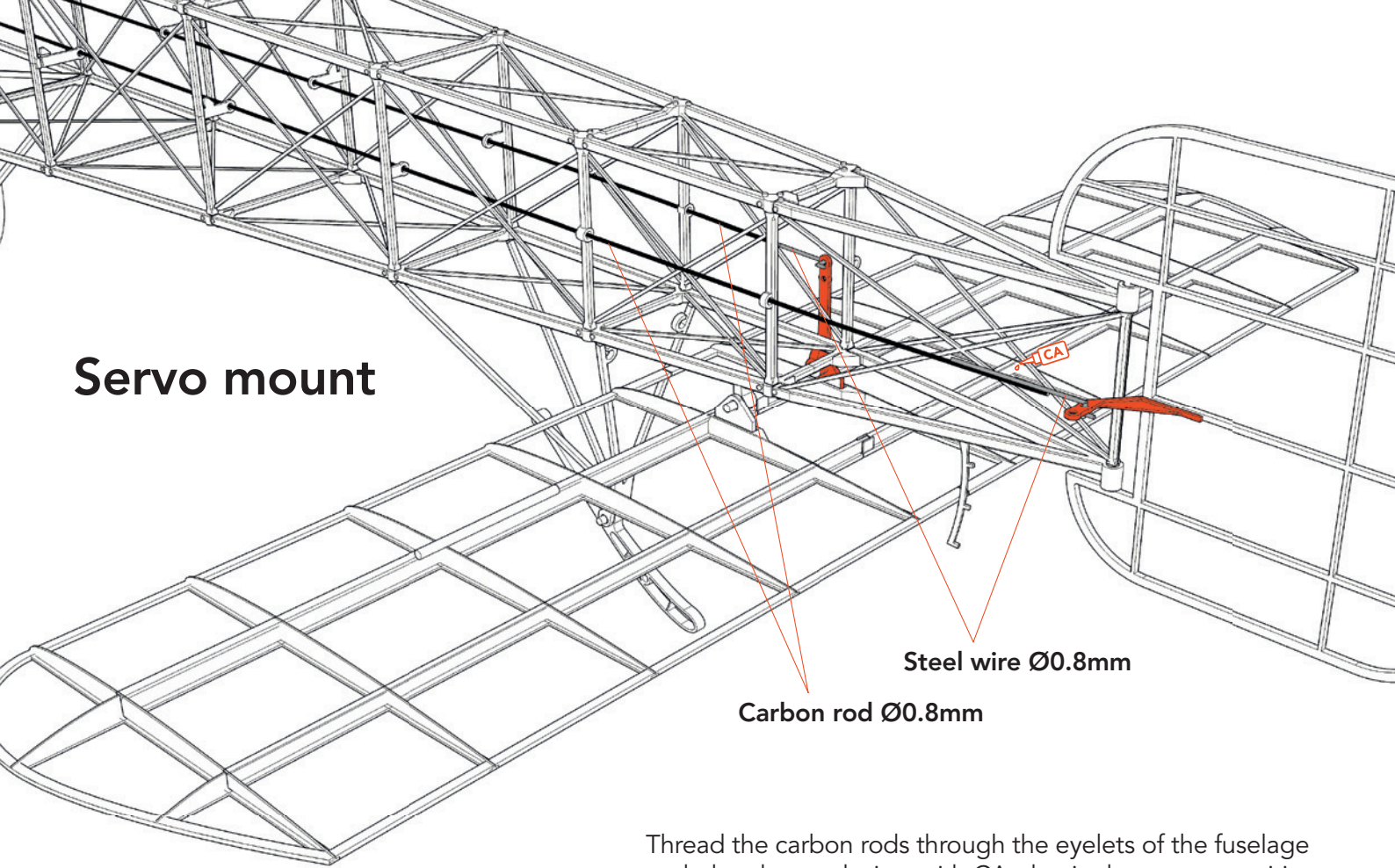

Thread the carbon rods through the eyelets of the fuselage and glue the steel wires with CA glue in the correct position (servo and rudder/elevator in zero position).

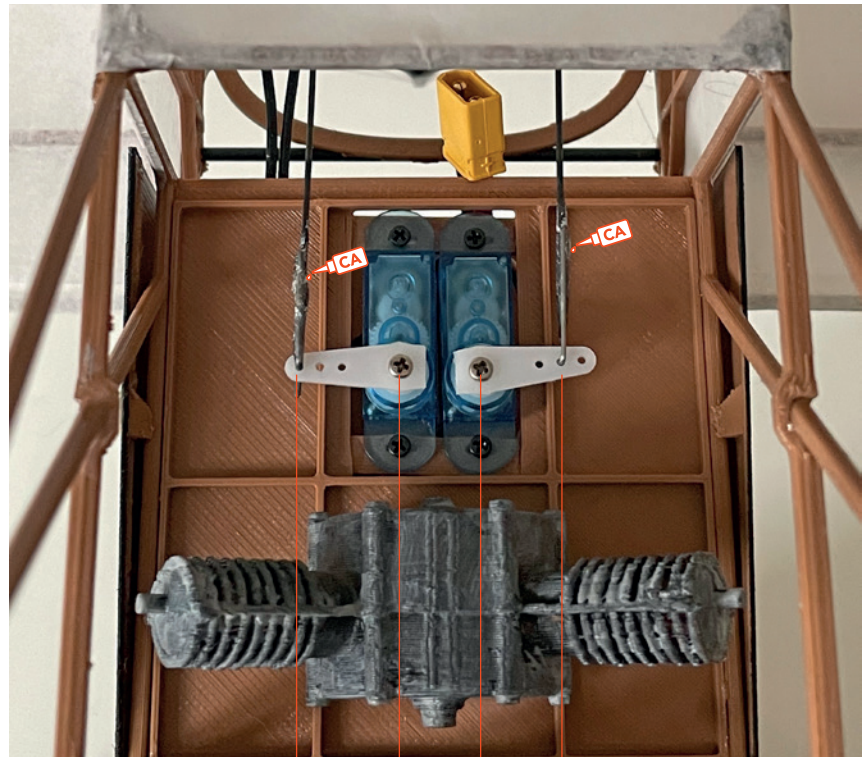
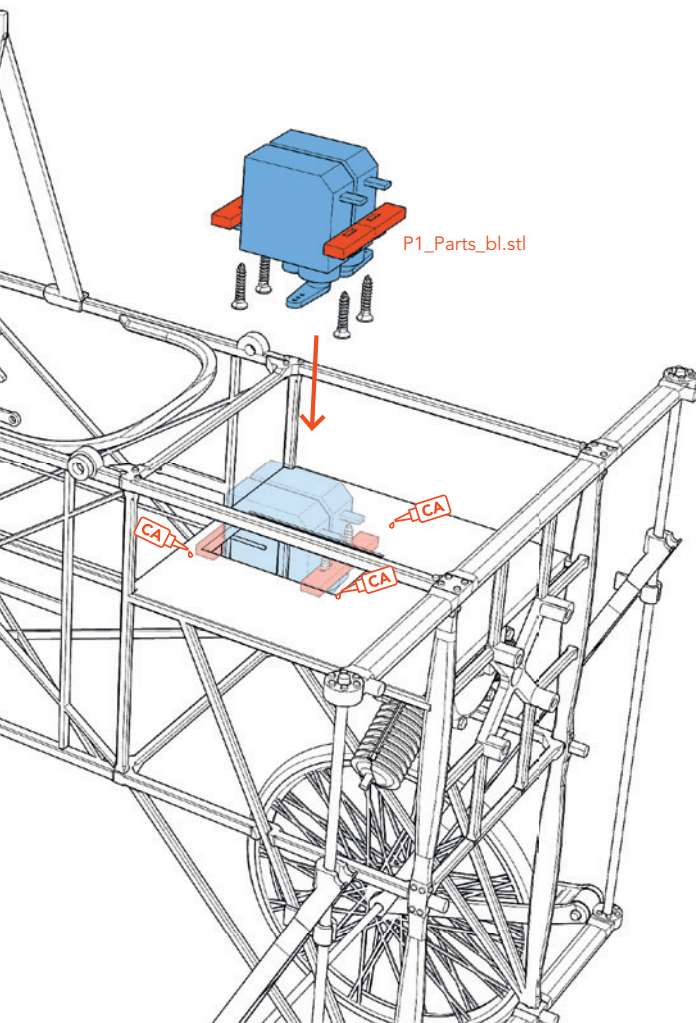

10 mm Rudder  
8 mm Elevator

# Instrument panel assembly

Print this page (format 100 %) and cut out the instruments on the right.

Then glue them behind the frames as shown in the picture.

The spherical tank should be painted in brass or gold.

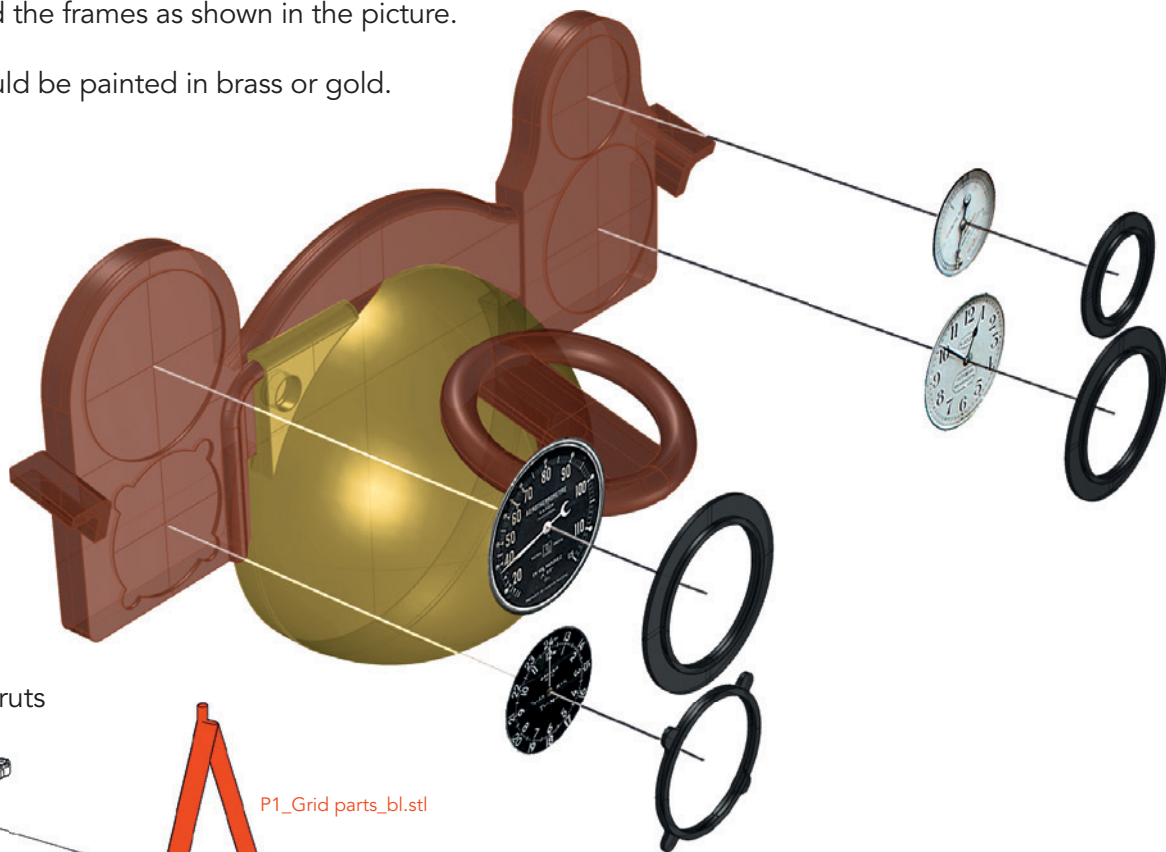

Glue the upper wing struts to this position.

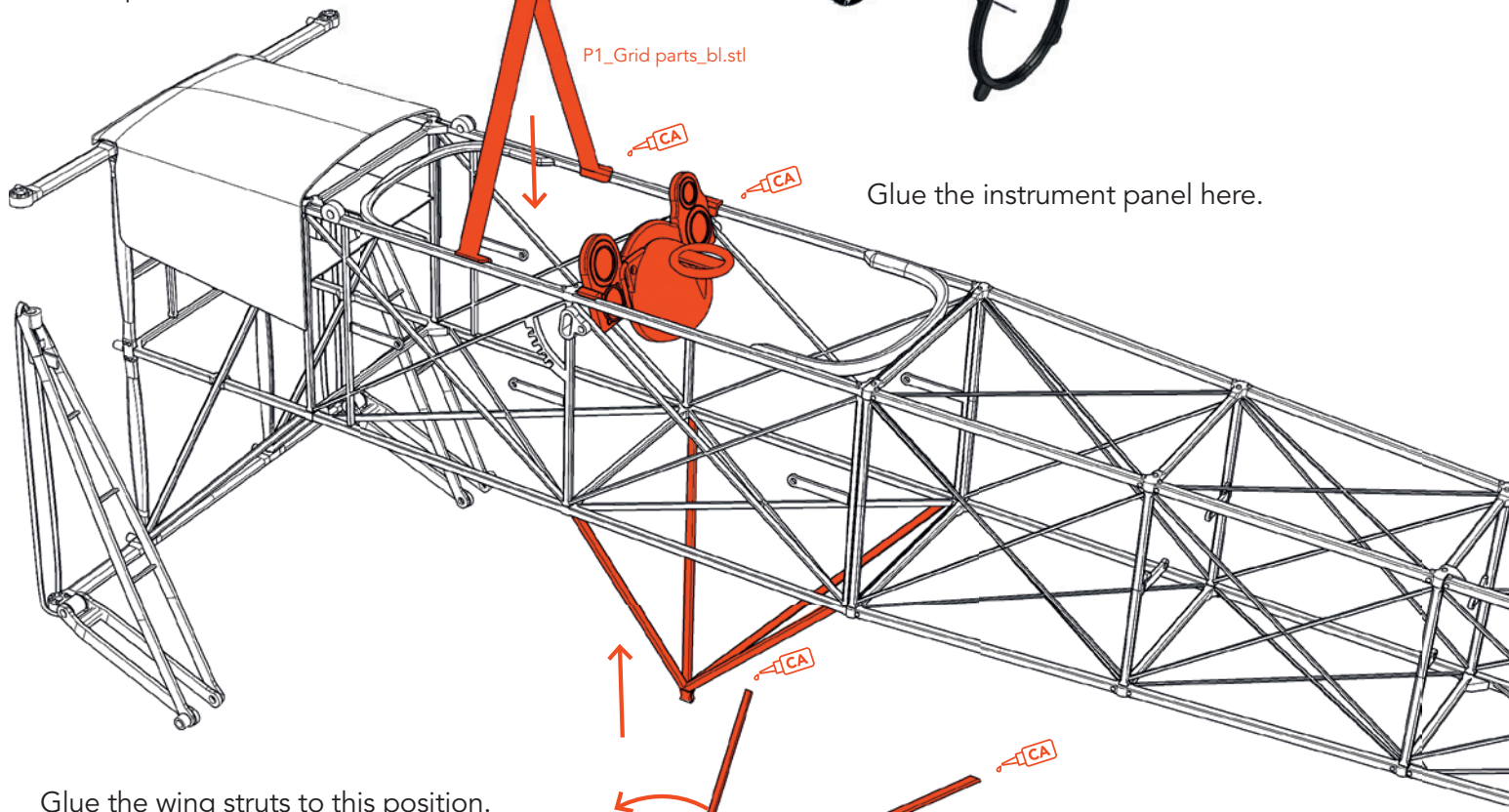

Glue the instrument panel here.

Glue the wing struts to this position.

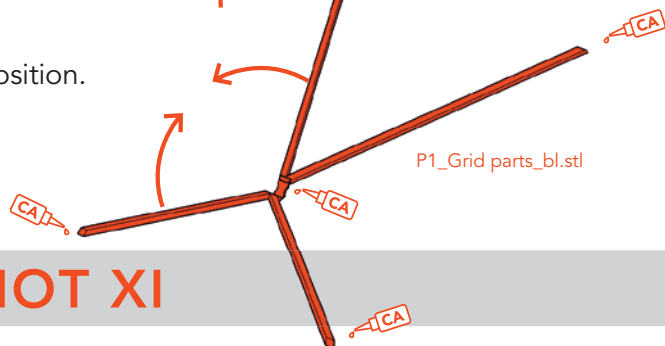

# Wing ropes

Carefully open the holes in the paper and thread the twine through the wing from above.

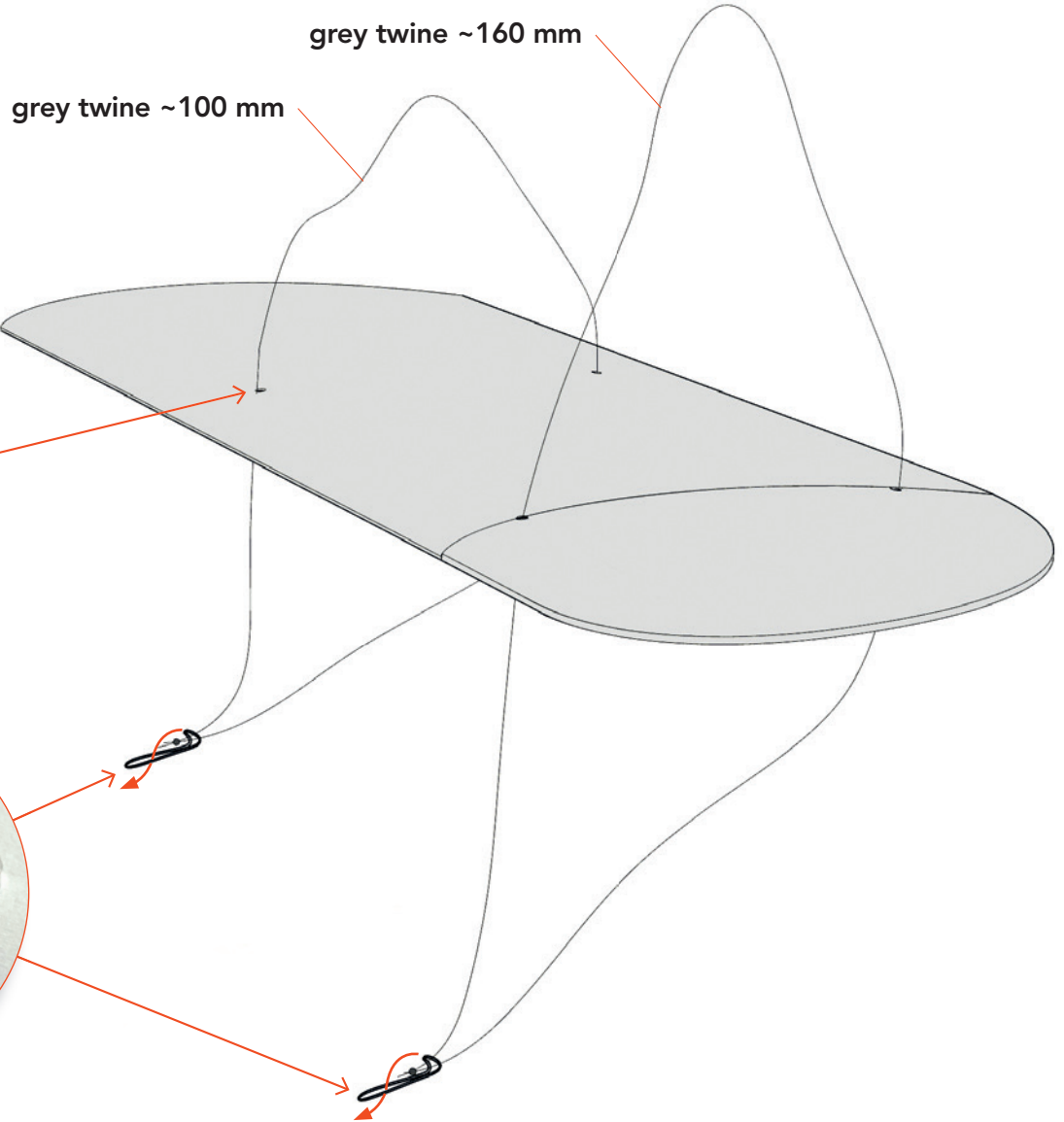
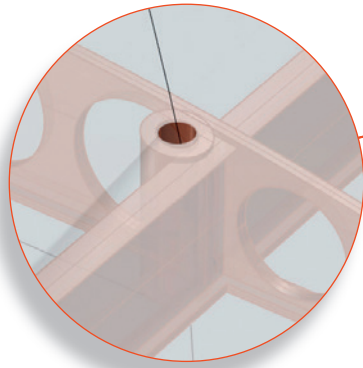

Attach the wings to the fuselage as shown in the picture, hang the wing ropes on the top and then on the bottom. The ropes should NOT be glued to the wing!

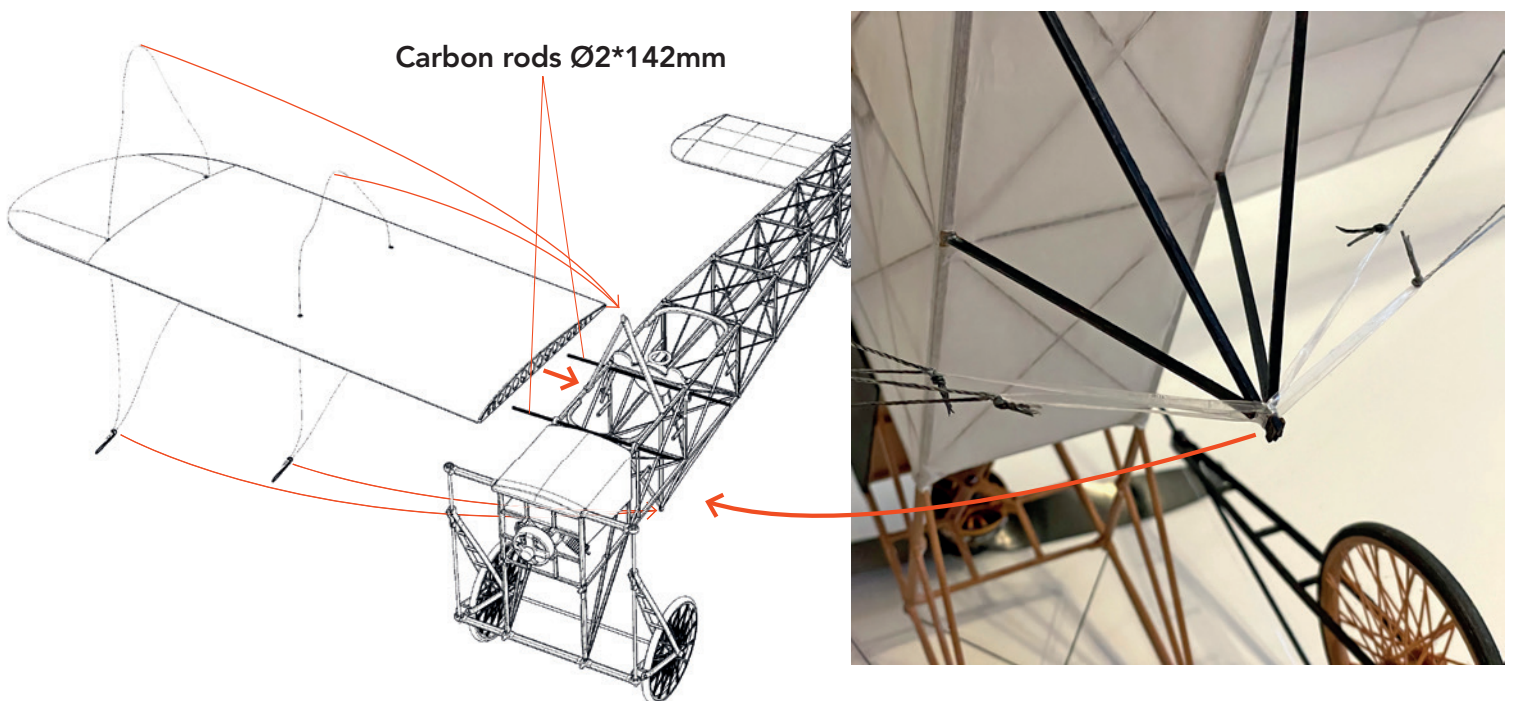

# RC components

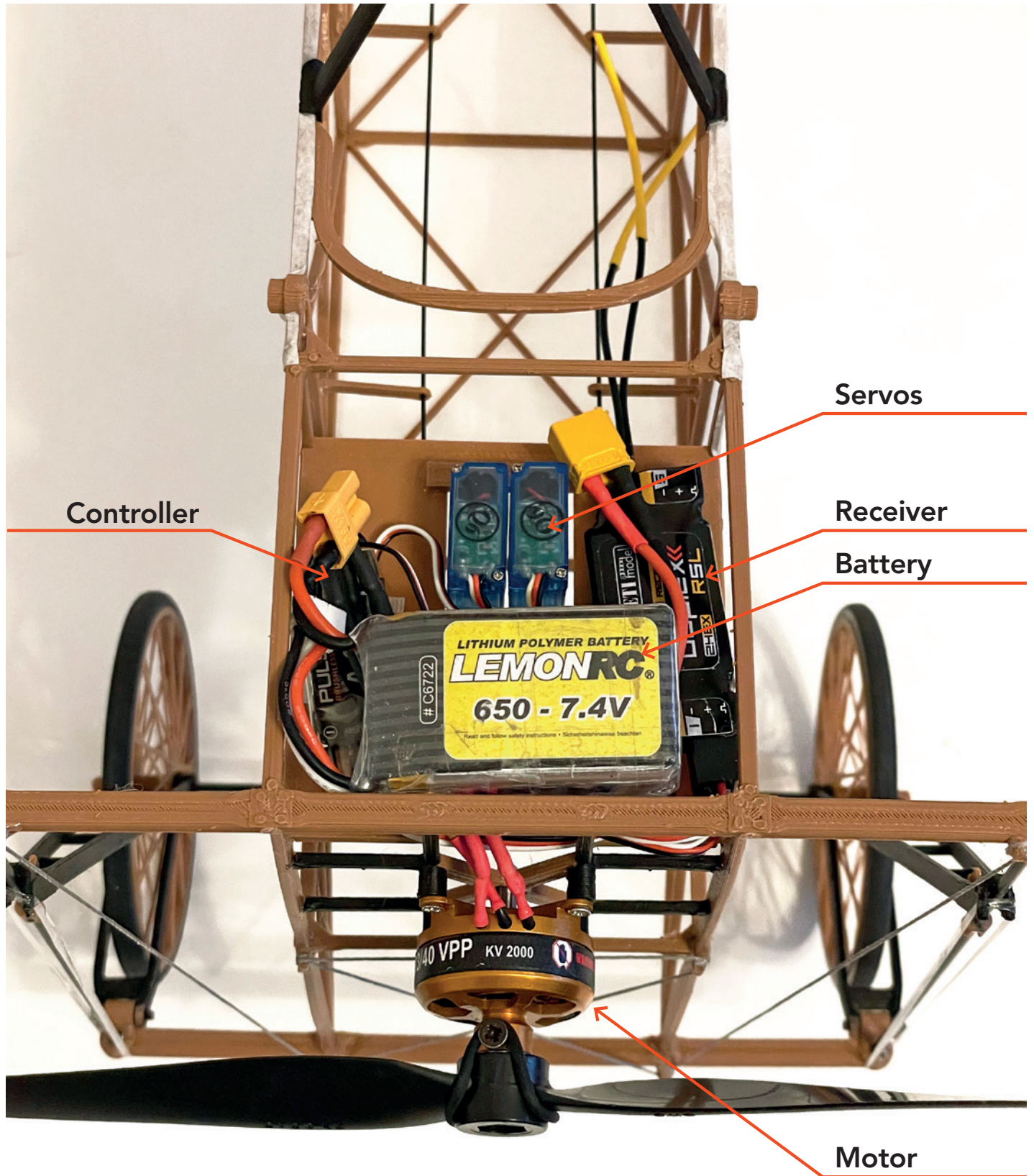

# Motor and hood

**SAFETY FIRST** Use appropriate screws for motor mounting to ensure safe operation! Make sure the prop runs smoothly and does not generate vibrations. **Check regularly that the motor mounting is absolutely tight!**

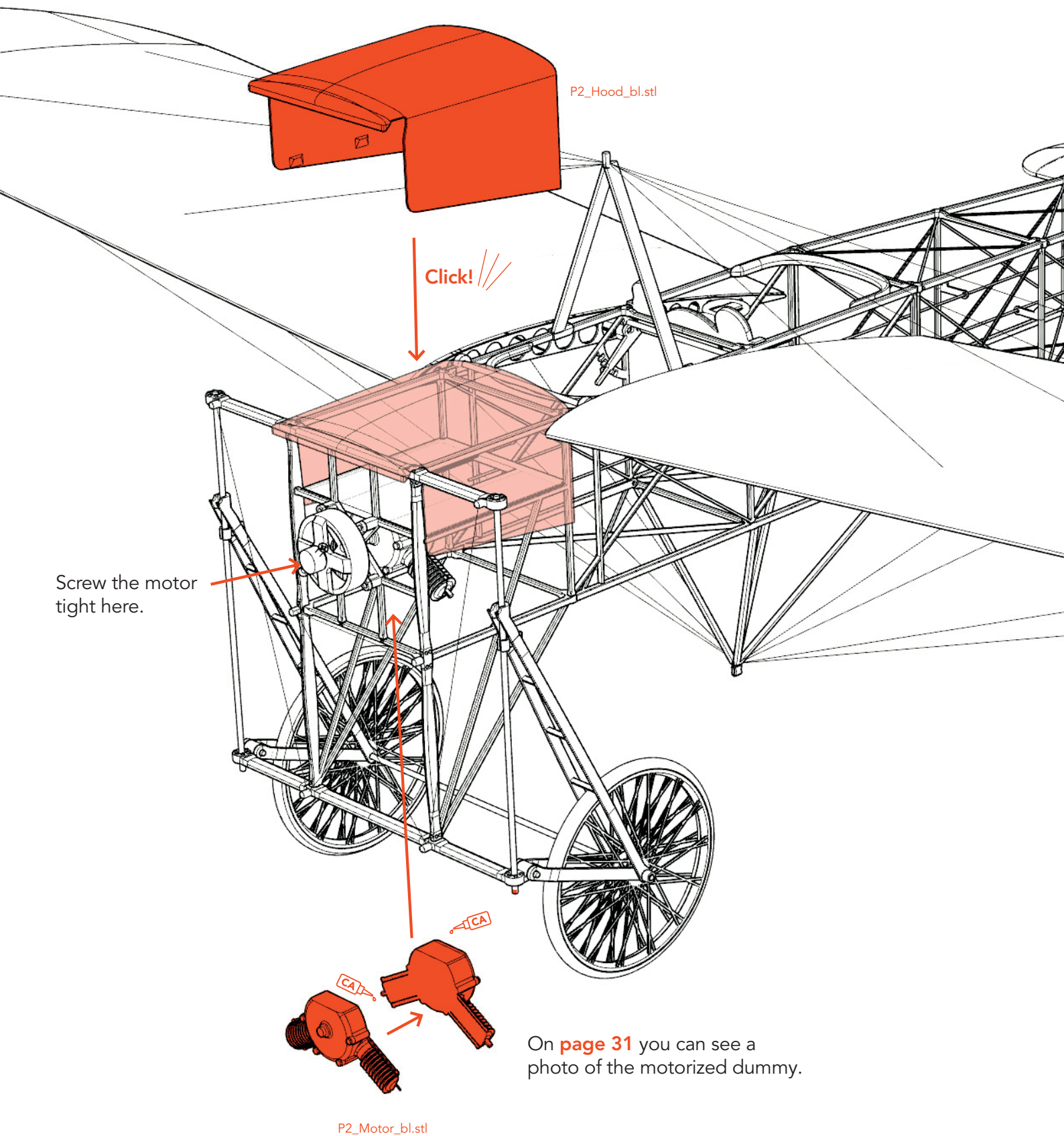

On **page 31** you can see a photo of the motorized dummy.

# Wing adjustment and AOI

Since it is difficult to string the wings absolutely flat, there is the possibility to adjust the **Angle of Incidence (AOI)** for both wings separately. No tools are necessary and you can adjust the angle at any time.

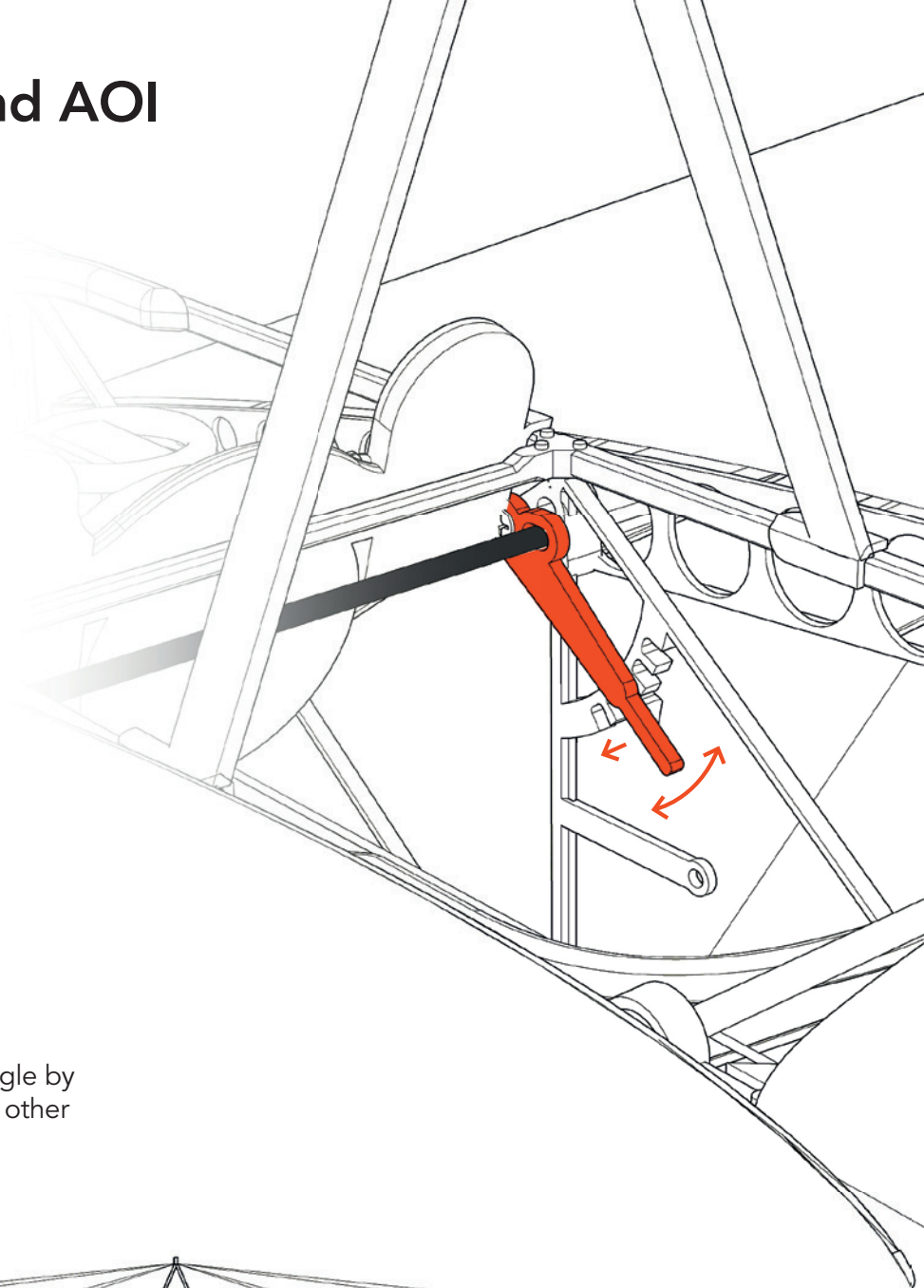
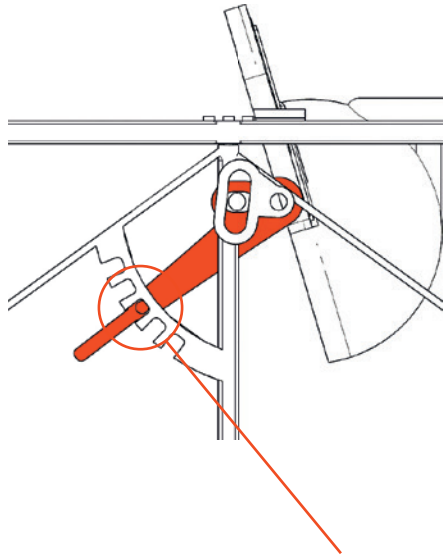

The correct AOI is in the **middle setting**. If a wing is slightly twisted, change the angle by one notch. If it is not enough, change the other wing in the opposite direction.

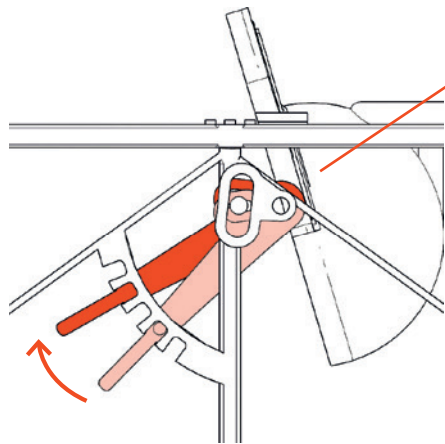
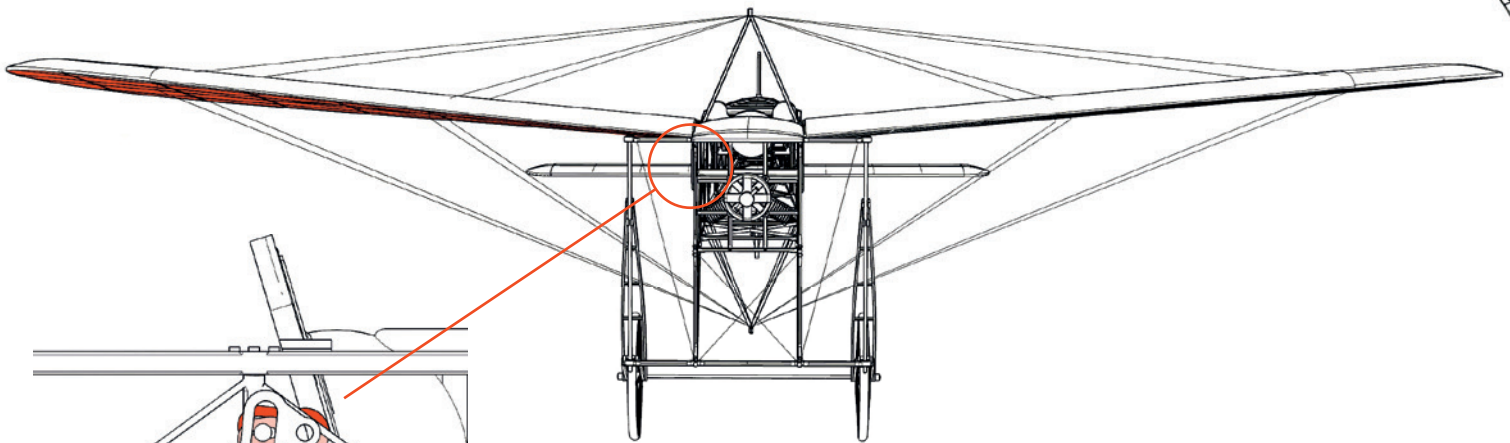

**IMPORTANT** Due to changes in temperature and humidity, **check before flight that the wings are as parallel as possible** by looking from exactly in front or behind, otherwise **correct it with the AOI levers**.

# Technical specifications

**WINGSPAN** 1016 mm/40 inches

**LENGTH** 800 mm/31 inches

**FLIGHT WEIGHT** 285 grams

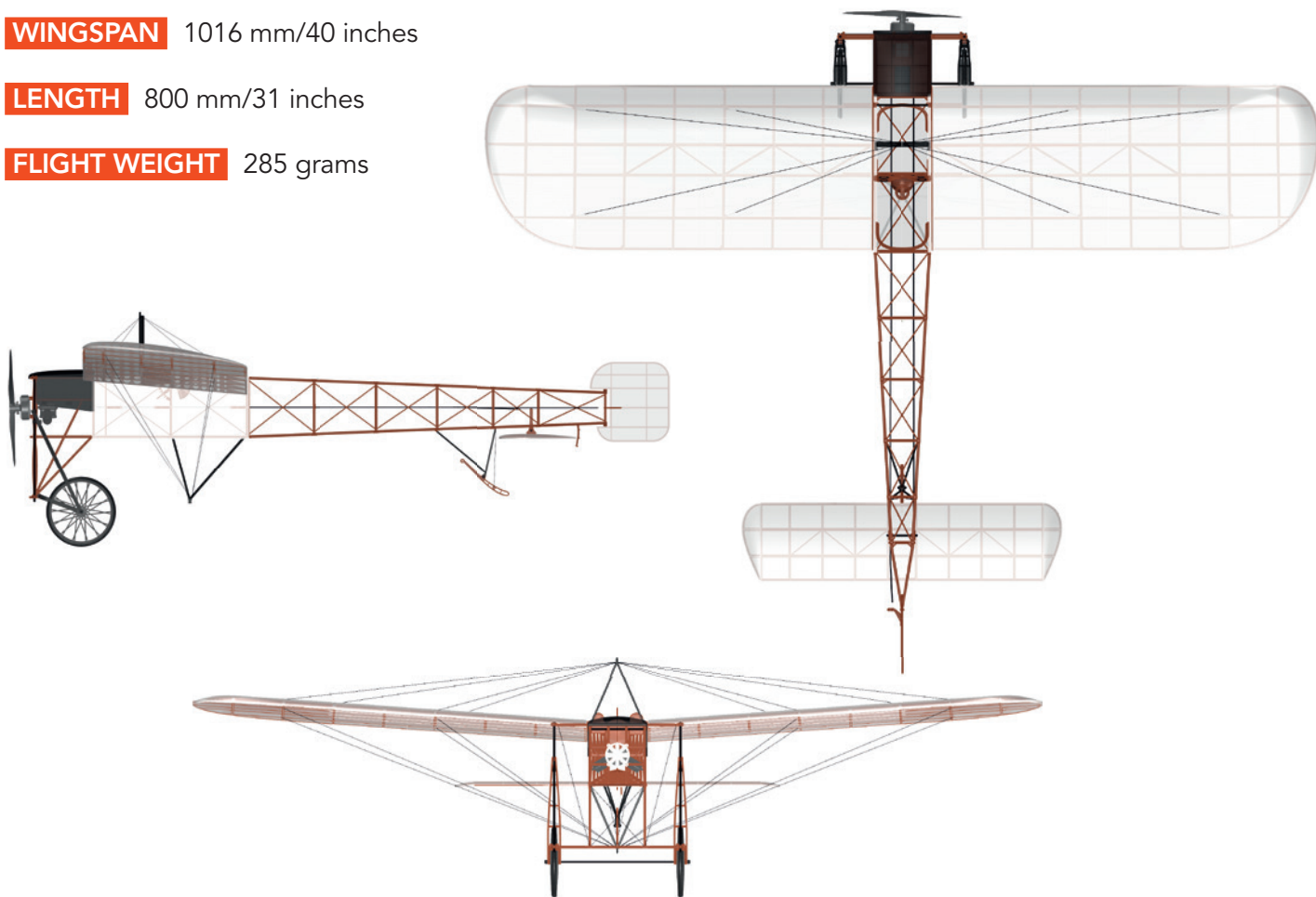

## Center of Gravity (CG)

The CG fits when the aircraft is pitching slightly backward when balanced on the **second spar**.

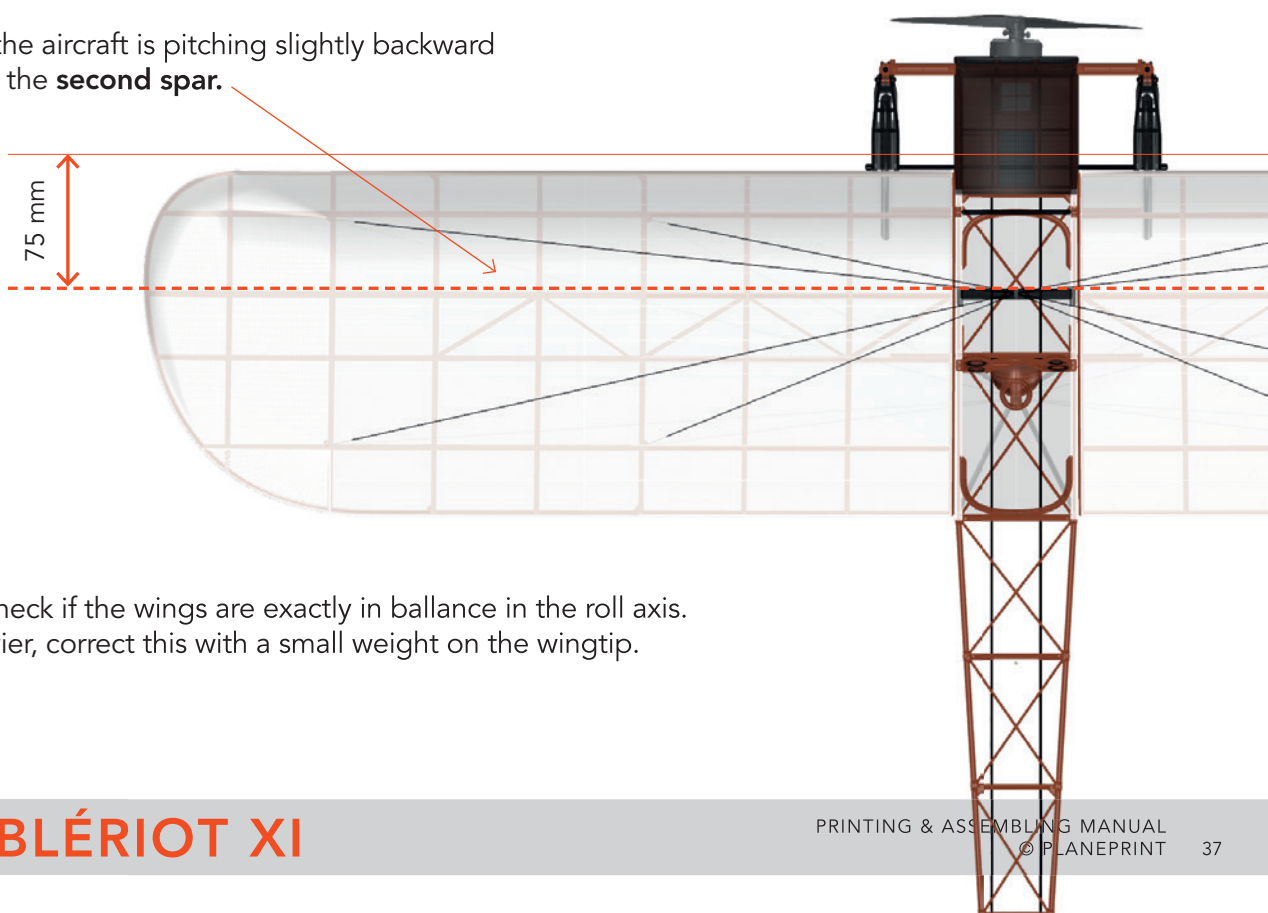

Do not forget to check if the wings are exactly in ballance in the roll axis. If one wing is heavier, correct this with a small weight on the wingtip.

# Settings for flying

When checking the control directions, **look at the elevator from left.**

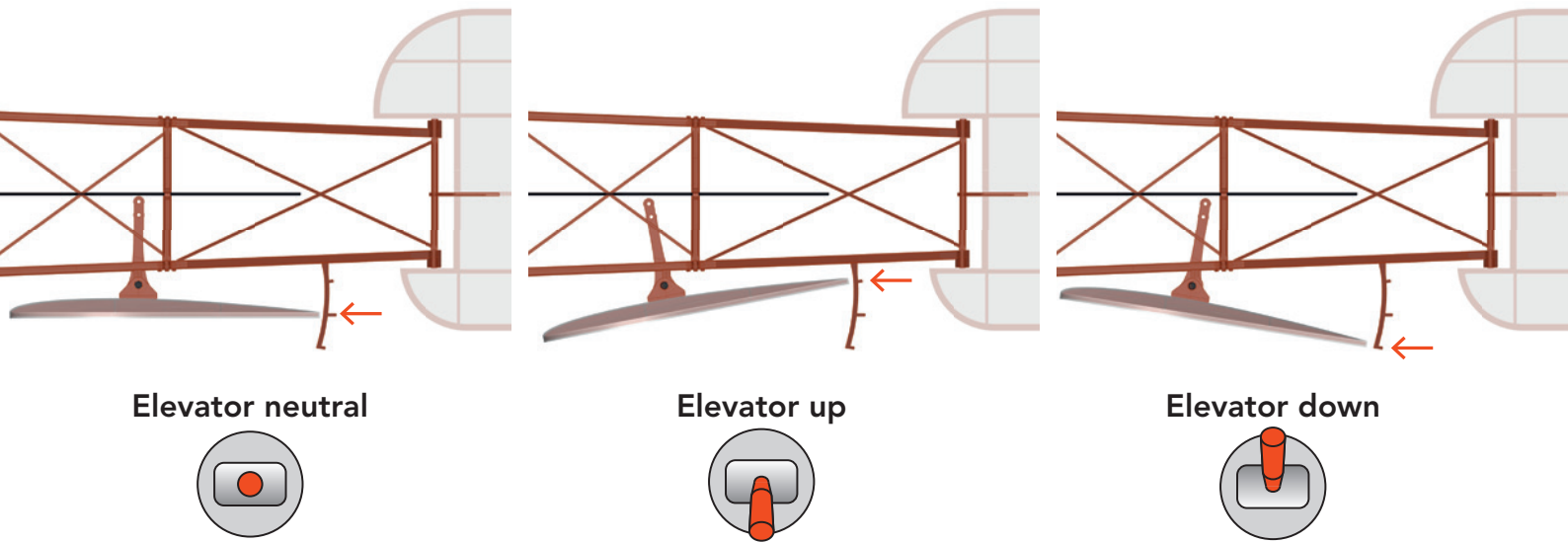

When checking the control directions, **look at the rudder from above.**

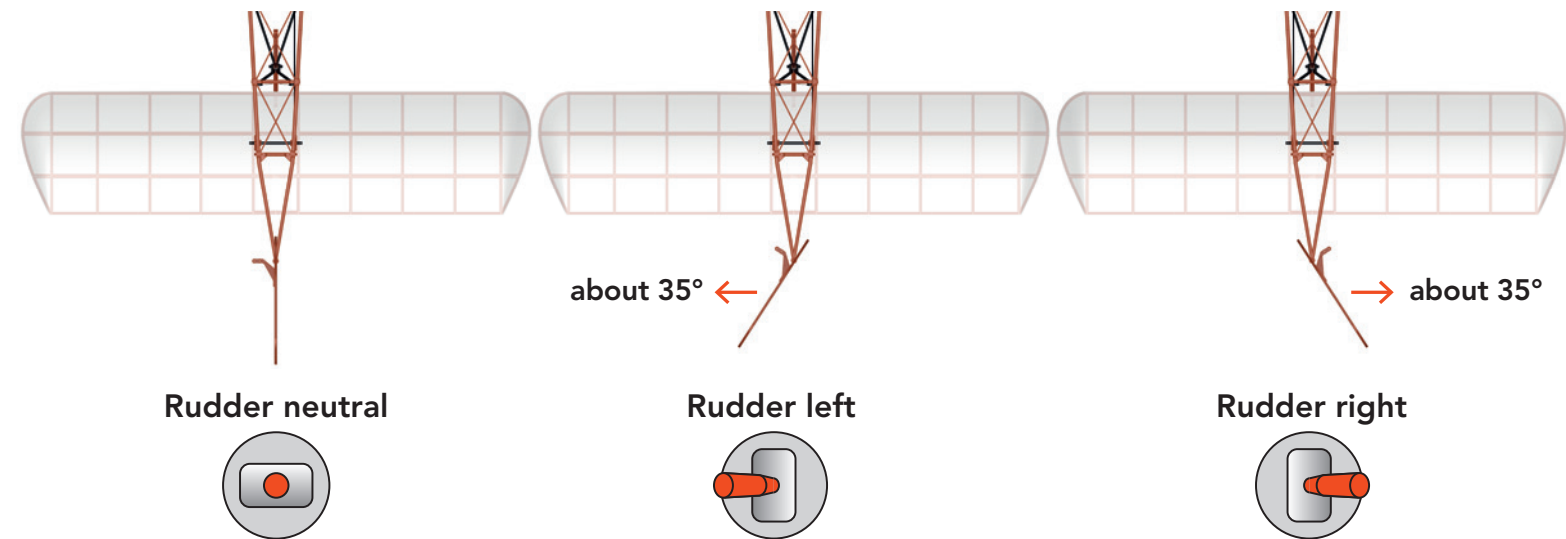

## Expo setting

**ELEVATOR** 30 %

**RUDDER** 30 %

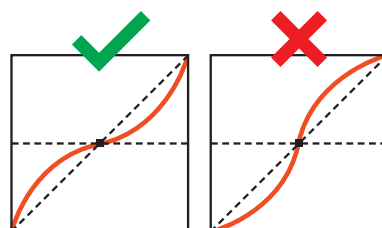

(for some remote controls a minus has to be in front of the number)

# AGE RECOMMENDATION 14+

## NOT FOR CHILDREN UNDER 14 YEARS. THIS IS NOT A TOY!

The STL data (or data processed from it, such as G codes) must never be passed on to third parties!

The purchase of the STL does not authorize the production of models for third parties.

By using the download data, an RC model airplane, called „model“ for short, can be manufactured using a 3D printer. As a user of this model, only you are responsible for safe operation that does not endanger you or others, or that does not damage the model or property of others.

PLANEPRINT.com assumes no responsibility for damage to persons and property caused by pressure, transport or use of the product. Filaments, printing supplies, hardware or consumables that can not be used after faulty 3D printing will not be replaced by PLANEPRINT.com in any way.

When operating, always keep a safe distance from your model in all directions to avoid collisions and injuries.

This model is controlled by a radio signal. Radio signals can be disturbed from outside without being able to influence it. Interference can lead to a temporary loss of control.

Always operate your model on open terrains, far from cars, traffic and people.

Always follow the instructions and warnings for this product and any optional accessories (servos, receivers, motors, propellers, chargers, rechargeable batteries, etc.) carefully.

Keep all chemicals, small parts and electrical components out of the reach of children.

Avoid water contact with all components that are not specially designed and protected. Moisture damages the electronics.

Never take an item of the model or accessory in your mouth as this can lead to severe injuries or even death.

Never operate your model with low batteries in the transmitter or model.

Always keep the model in view and under control. Use only fully charged batteries.

Always keep the transmitter switched on when the model is switched on.

Always remove the battery before disassembling the model.

Keep moving parts clean and dry at all times.

Always allow the parts to cool before touching them.

Always remove the battery after use.

Make sure that the Failsafe is properly set before the flight.

Never operate the model with damaged wiring.

Never touch moving parts.

We develop our models to the best of our knowledge and belief. We accept no liability for consequential damage and injuries caused by improper use or incorrectly printed parts. **Please be careful when handling motors, batteries and propellers** and only move your model with insurance and in approved places!

# PLANE PRINT