

# FOUGA MAGISTER



**NOTE:** Slicing only works with CURA!



You can find the STL data at [www.planeprint.com](http://www.planeprint.com)

# PRINTING THE PARTS – PRINTING PROFILES

You may wonder why this 3D model is suitable exclusively for CURA right?

The most important thing about small RC model airplanes is always the ratio of size to weight. The lighter a model is, the better its flight characteristics and also the flight time is significantly increased.

With our unique design process, we manage to make Weights relevant items in a **true 1-wall printing process** for the outer skin but also for the filling offer. So we save weight while maintaining the necessary stability.

Here we show you how to get started from a standard CURA profile Make settings. For this model we only need 4, easy to create profiles.

It is **absolutely necessary** to observe the information provided by **PLANEPRINT.com** in order: to slice the component correctly. However, it may make sense to perfect your 3D printing by additionally performing several hiring activities depending on your printer and the filament used.

## STEP 1:

For slicing all Planeprint models, four profiles have to be created in Cura:

PROFILE P1\_fullbody  
PROFILE P2\_hollowbody  
PROFILE P3\_surface  
PROFILE P4\_flex

You can find the description at [www.planepprint.com/print](http://www.planepprint.com/print)

## IMPORTANT FOR THE 1-WALL-PRINT!

In order to print airfoils of the lowest possible weight with high stability, it is necessary to print with only one wall line (Nozzle 0.4 mm). Decisive here is the adhesion between the layers! To achieve this, you must print at a much higher temperature than normal. As a **guideline**, 230 ° C is a good starting point. The parts-cooling fan should be set to 0% or a maximum of 20%. Since not every printer works the same, it may be necessary to make small adjustments to these settings.



The development of a complex, airworthy RC flight model to express on any standard 3D printer is a very complex and extensive process. Therefore, we appeal to your fairness not to forward the STL data you have acquired to third parties. Our STL files are provided with indelible copyright watermarks that can be verified at any time.

**Thank you for your understanding and have fun with your PLANEPRINT MODEL!**

# PROFILE P1\_FULLBODY

The following parts must be sliced with the PROFILE P1\_FULLBODY.  
Please note the additional settings for the individual parts!

fm\_battery holder\_profile1.stl

**MATERIAL** PLA, Weight: ~ 6 g

**ADDITIONAL SETTINGS**

None required

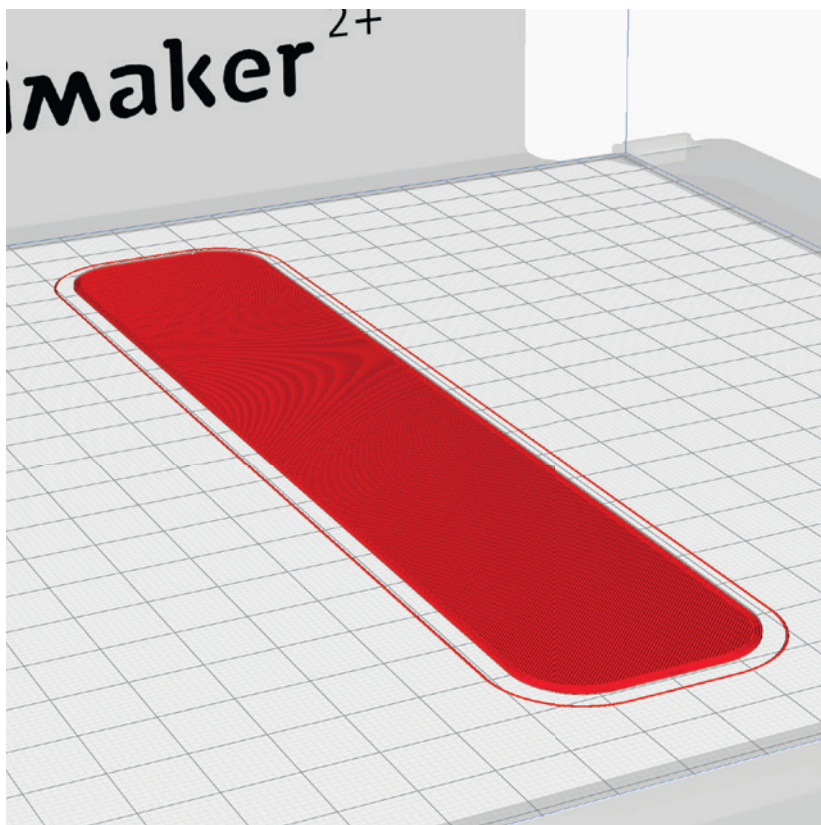

fm\_Gear Covers\_profile1.stl

**MATERIAL** PLA, ~ 3 g

**ADDITIONAL SETTINGS**

None required

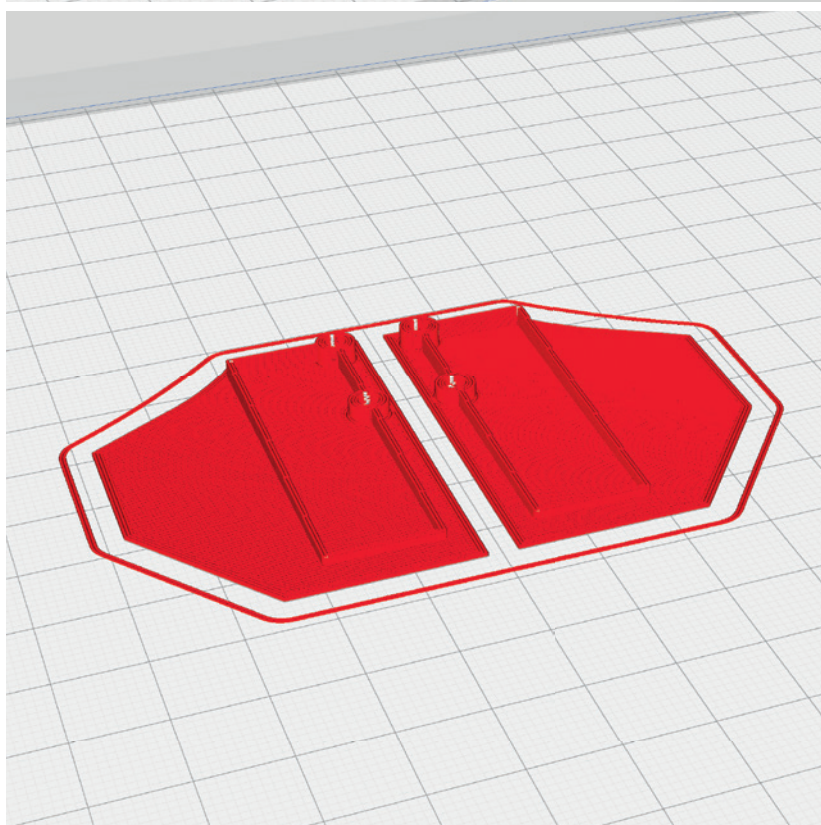

# PROFILE P1\_FULLBODY

The following parts must be sliced with the PROFILE P1\_FULLBODY.  
Please note the additional settings for the individual parts!

## fm\_Gear nose\_profile1.stl

**MATERIAL** PLA, ~ 8 g

### ADDITIONAL SETTINGS

- Wall Line Count 3

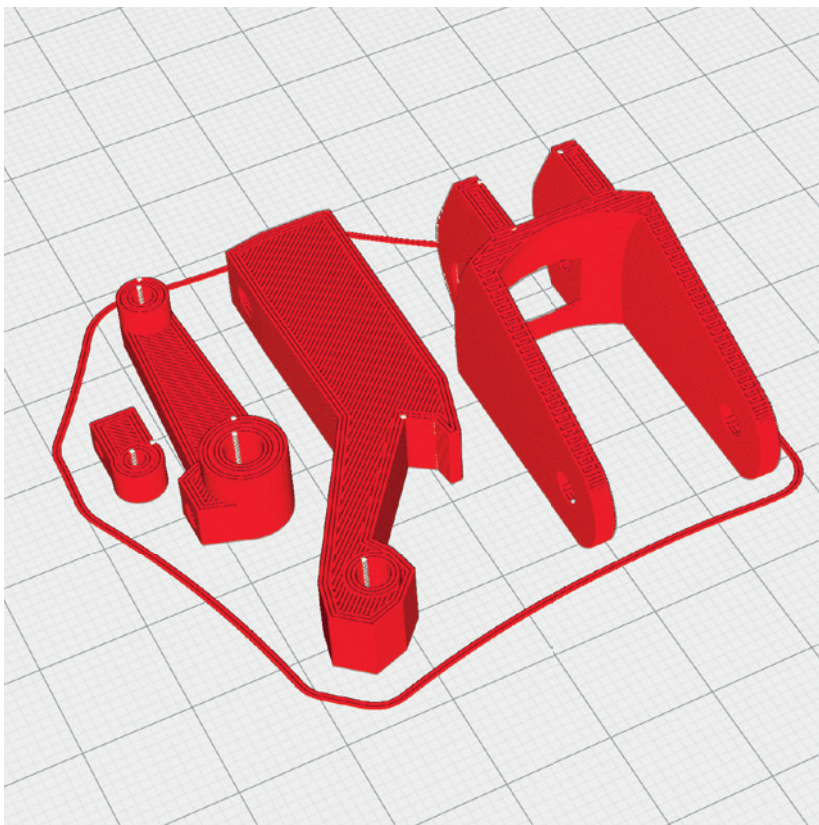

## fm\_Gear main\_profile1.stl

**MATERIAL** PLA, ~ 16 g

### ADDITIONAL SETTINGS

- Wall Line Count 3

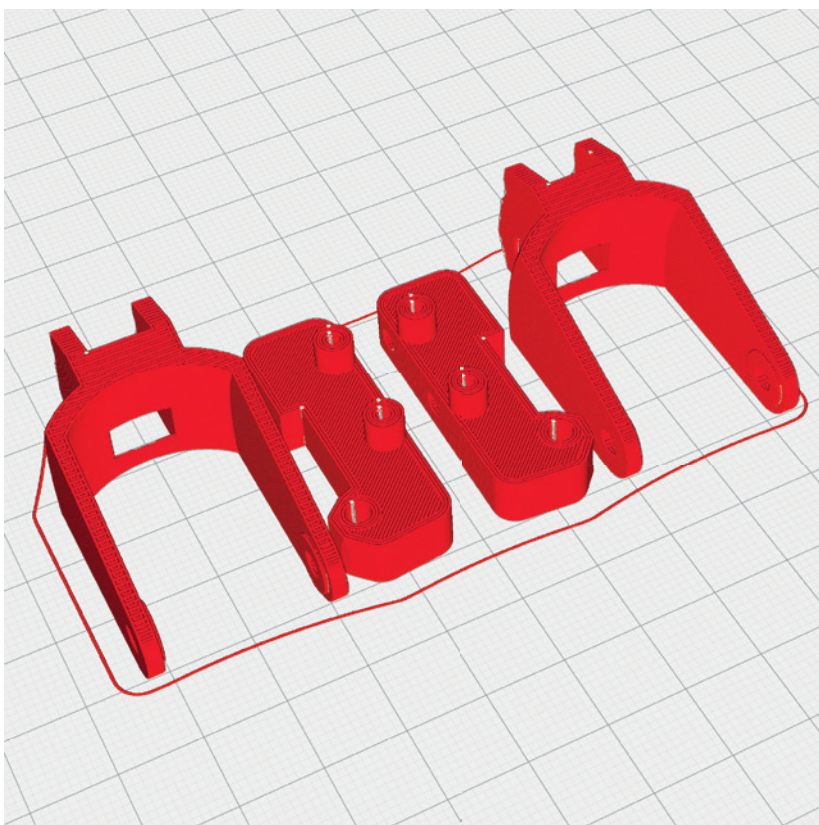

# PROFILE P1\_FULLBODY

The following parts must be sliced with the PROFILE P1\_FULLBODY.  
Please note the additional settings for the individual parts!

## fm\_Interconnects\_profile1.stl

**MATERIAL** PLA, ~ 3 g

### ADDITIONAL SETTINGS

None required

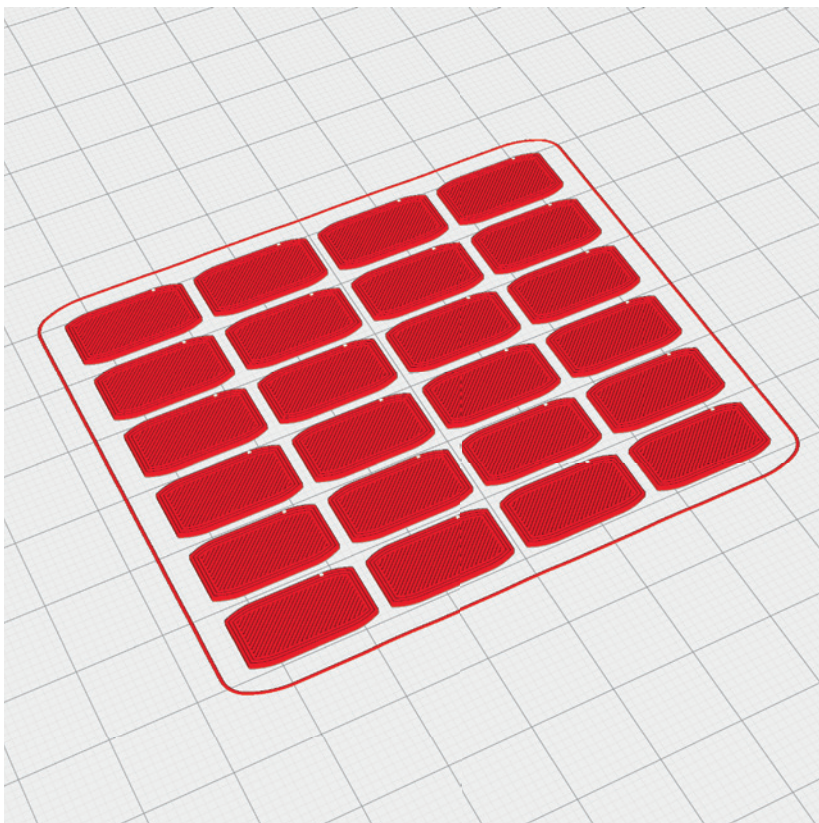

## fm\_Lights\_profile1.stl

**MATERIAL** transparent PLA, ~ 3 g

### ADDITIONAL SETTINGS

- Wall Line Count 10

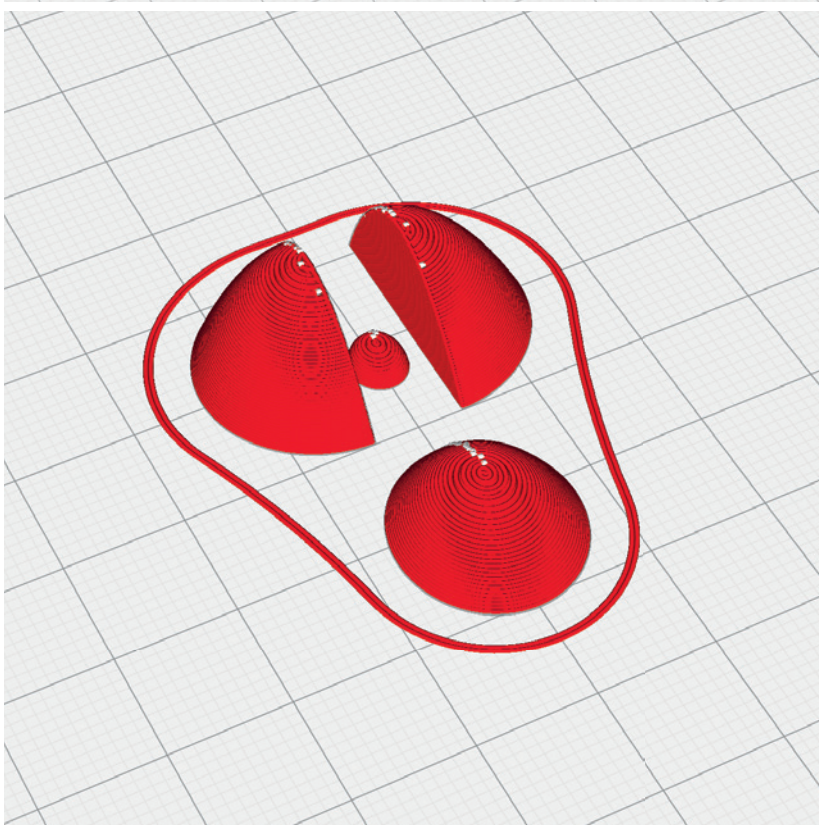

# PROFILE P1\_FULLBODY

The following parts must be sliced with the PROFILE P1\_FULLBODY.  
Please note the additional settings for the individual parts!

fm\_Parts\_profile1.stl

**MATERIAL** PLA, ~ 12 g

**ADDITIONAL SETTINGS**

None required

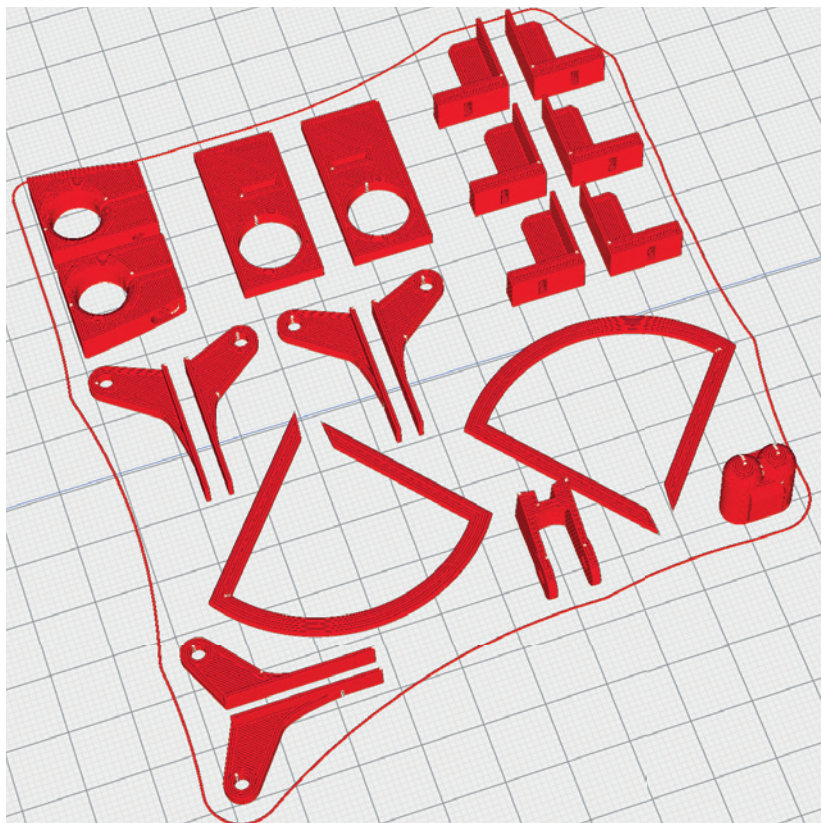

fm\_Rims\_profile1.stl

**MATERIAL** PLA, ~ 7 g

**ADDITIONAL SETTINGS**

None required

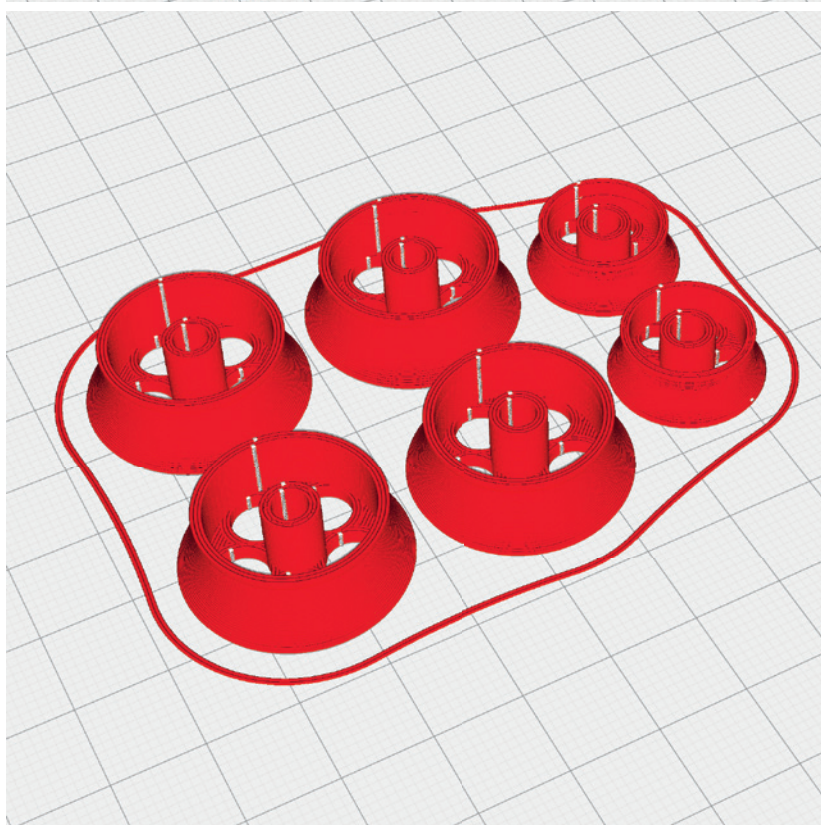

# PROFILE P1\_FULLBODY

The following parts must be sliced with the PROFILE P1\_FULLBODY.  
Please note the additional settings for the individual parts!

## fm\_Servocovers Ailerons\_xxx \_profile1.stl

**MATERIAL** PLA, ~ 6 g

### ADDITIONAL SETTINGS

None required

### INFO

There are different variants,  
look at the file name!

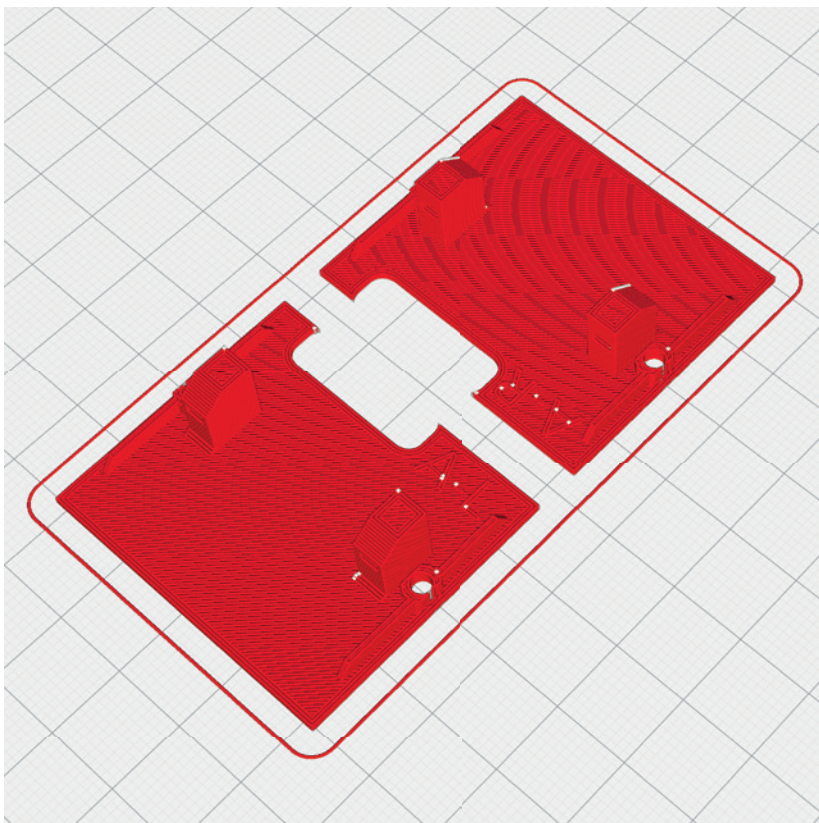

## fm\_Servocovers Flaps\_xxx \_profile1.stl

**MATERIAL** PLA, ~ 6 g

### ADDITIONAL SETTINGS

None required

### INFO

There are different variants,  
look at the file name!

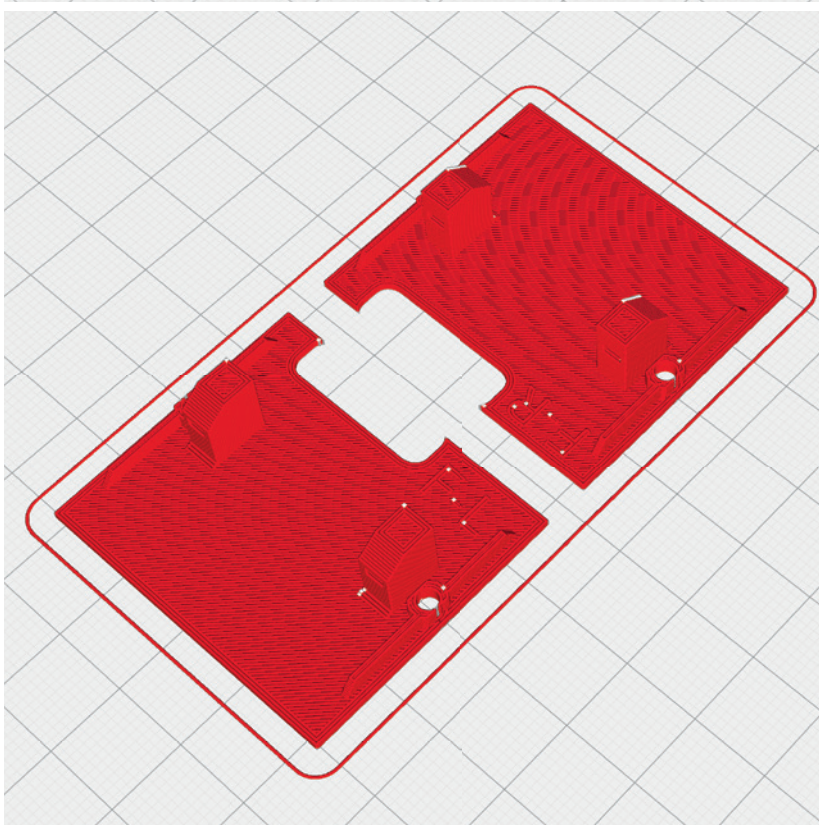

# PROFILE P1\_FULLBODY

The following parts must be sliced with the PROFILE P1\_FULLBODY.  
Please note the additional settings for the individual parts!

fm\_Nose detail\_profile1.stl

**MATERIAL** PLA, ~ 2 g

**ADDITIONAL SETTINGS**

None required

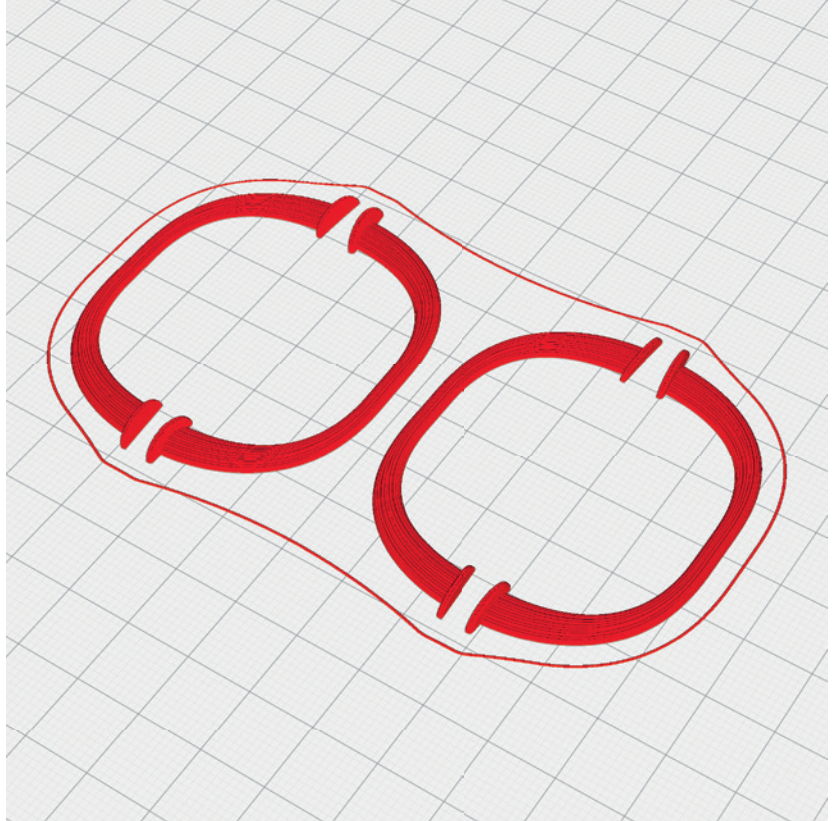

# PROFILE P2\_HOLLOWBODY

The following parts must be sliced with the PROFILE P2\_HOLLOWBODY.  
Please note the additional settings for the individual parts!

## fm\_Gear Brackets\_profile2.stl

**MATERIAL** PLA, ~ 5 g

### ADDITIONAL SETTINGS

- Wall Line Count: 5

View of the infill:

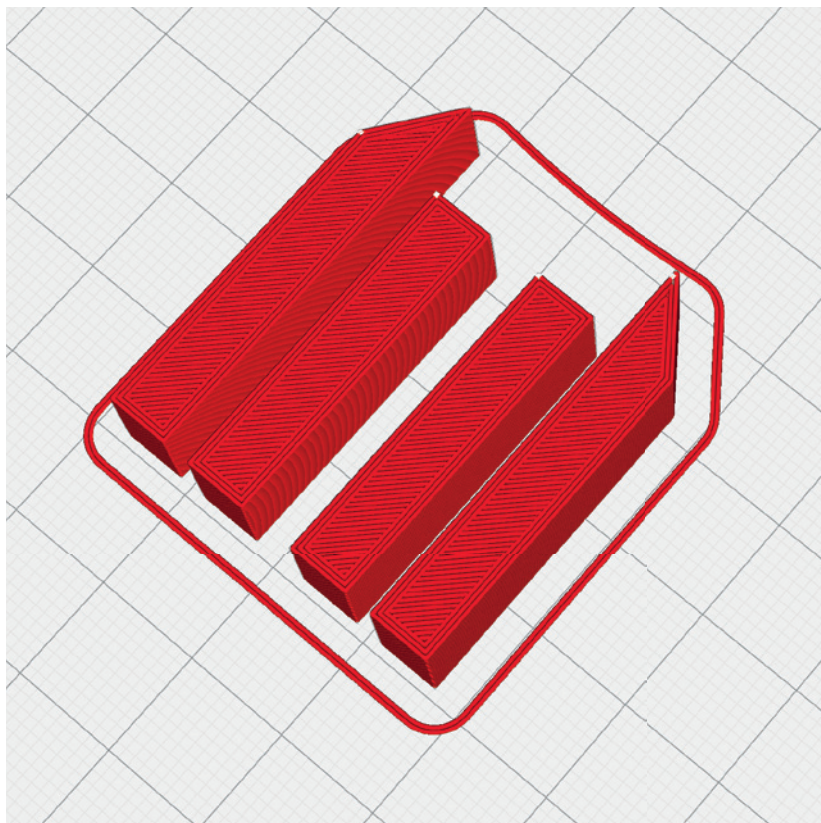
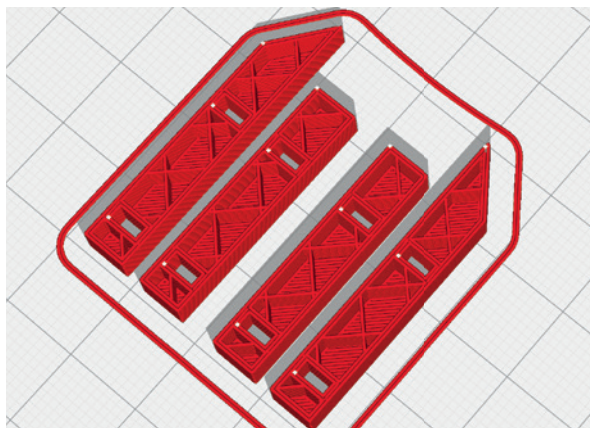

## fm\_Canopy Latch\_profile2.stl

**MATERIAL** PLA, ~ 3 g

### ADDITIONAL SETTINGS

None required

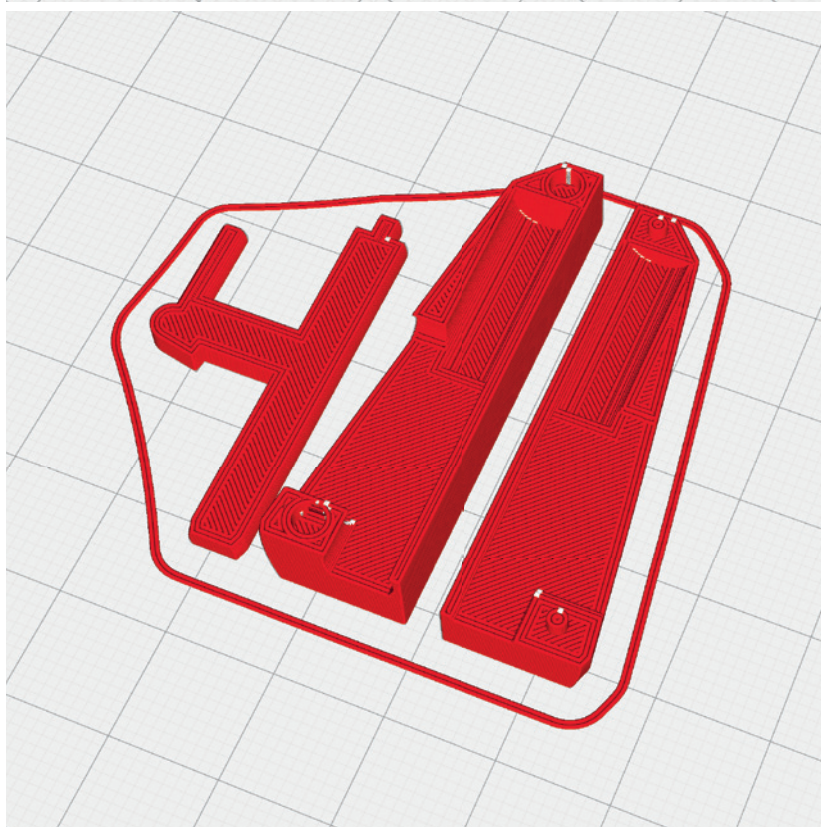

# PROFILE P3\_SURFACE

The following parts must be sliced with the PROFILE P3\_SURFACE (1-wall-print).

**Please note the additional settings for the individual parts!**

**PLEASE NOTE** In profile P3\_SURFACE, there should not be more than one STL on the buildplate at the same time, otherwise slicing errors can occur! Depending on your printer, a brim may not be required.

fm\_Aileron-left\_profile3.stl  
fm\_Aileron-right\_profile3.stl

**MATERIAL** PLA, ~ 15 g

**ADDITIONAL SETTINGS**

None required

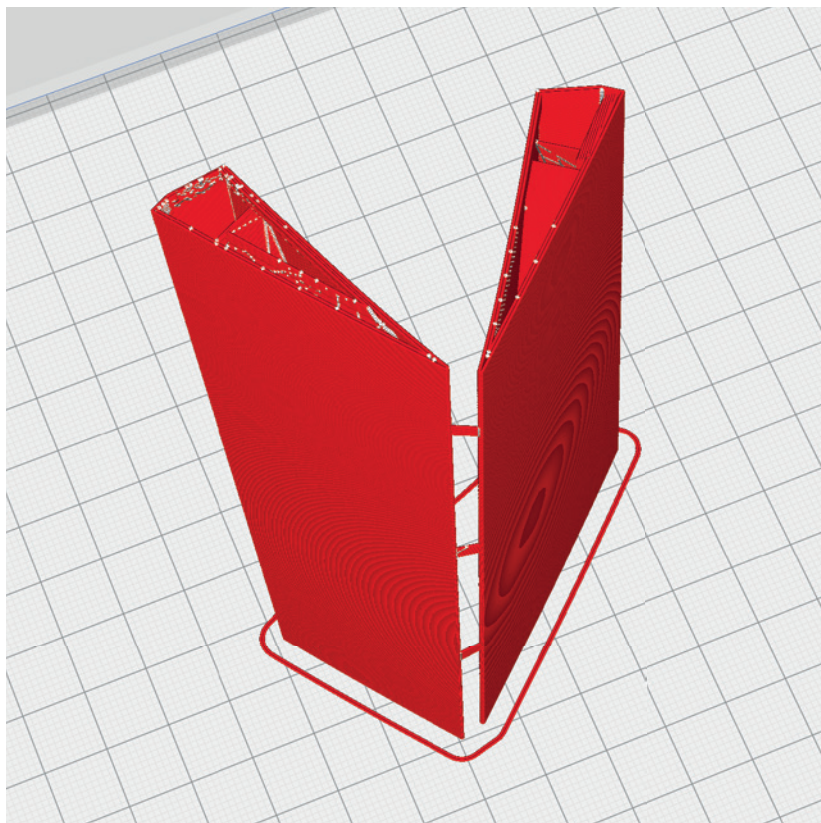

fm\_Canopy 1\_profile3.stl

**MATERIAL** PLA, ~ 24 g

**ADDITIONAL SETTINGS**

- Fan 80 % (in the upper range there is a risk of overheating)

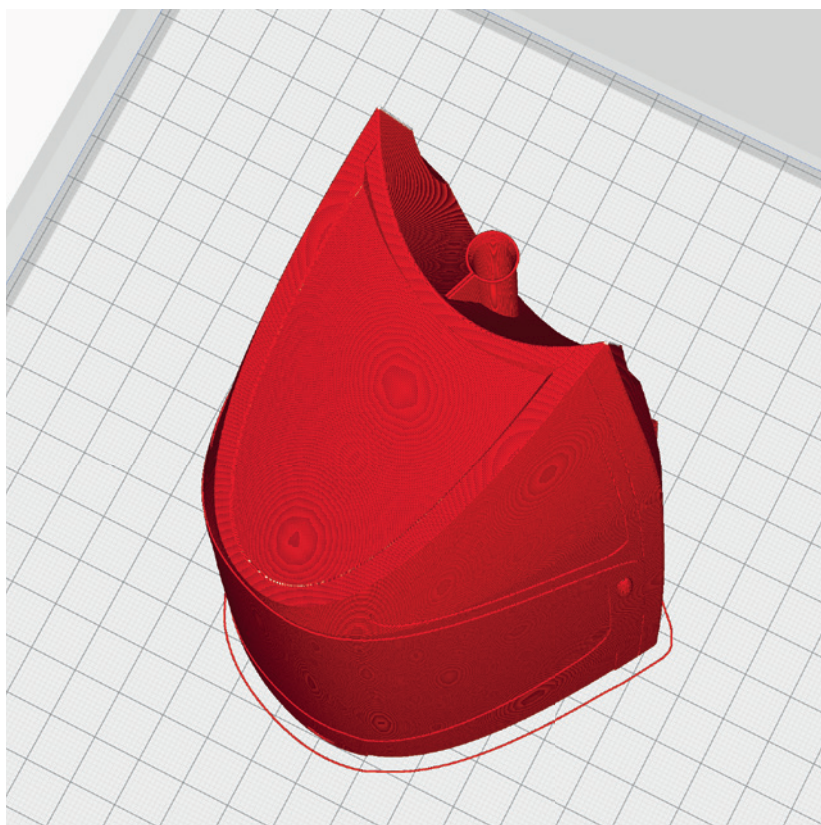

# PROFILE P3\_SURFACE

The following parts must be sliced with the PROFILE P3\_SURFACE (1-wall-print).

**Please note the additional settings for the individual parts!**

**PLEASE NOTE** In profile P3\_SURFACE, there should not be more than one STL on the buildplate at the same time, otherwise slicing errors can occur! Depending on your printer, a brim may not be required.

## fm\_Canopy 2\_profile3.stl

**MATERIAL** PLA, ~ 24 g

### ADDITIONAL SETTINGS

None required

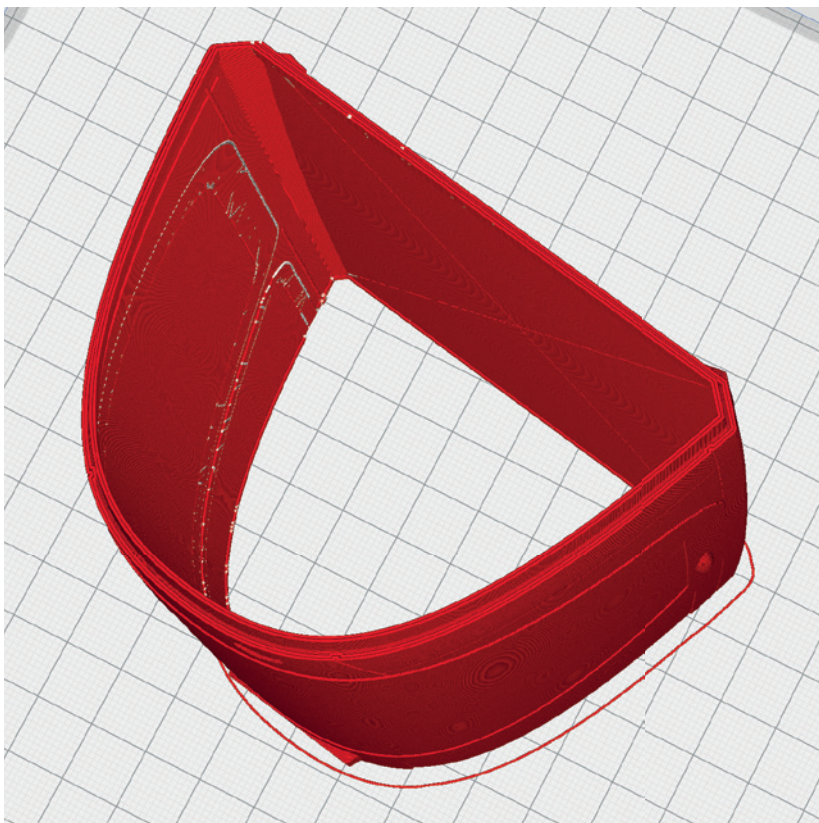

## fm\_Elevator 1\_profile3.stl

**MATERIAL** PLA, ~ 17 g

### ADDITIONAL SETTINGS

None required

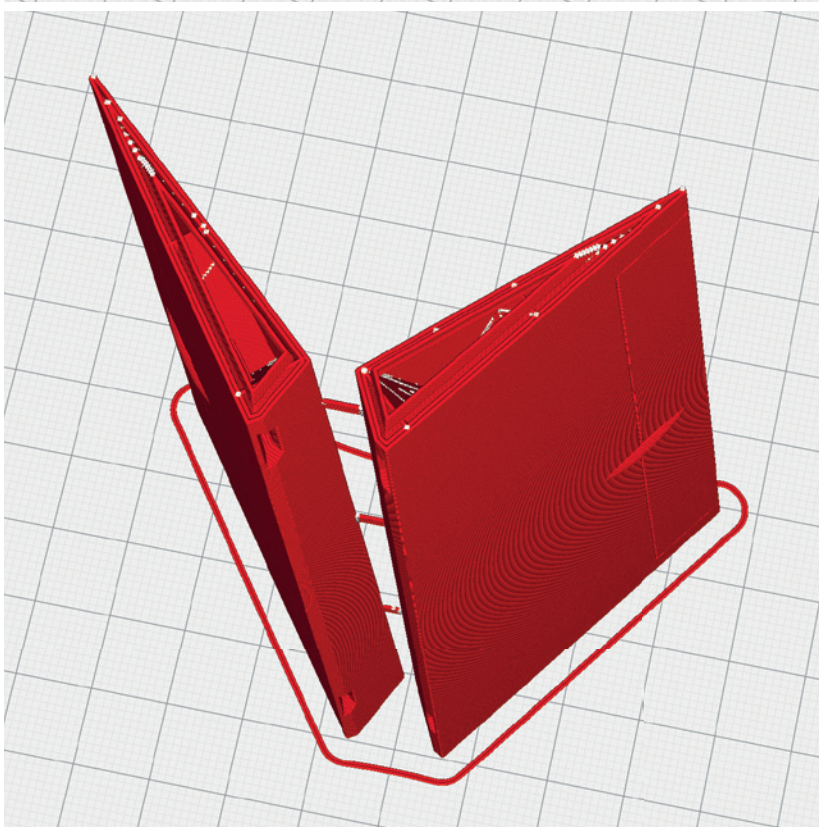

# PROFILE P3\_SURFACE

The following parts must be sliced with the PROFILE P3\_SURFACE (1-wall-print).

**Please note the additional settings for the individual parts!**

**PLEASE NOTE** In profile P3\_SURFACE, there should not be more than one STL on the buildplate at the same time, otherwise slicing errors can occur! Depending on your printer, a brim may not be required.

## fm\_Elevator 2\_profile3.stl

**MATERIAL** PLA, ~ 11 g

### ADDITIONAL SETTINGS

None required

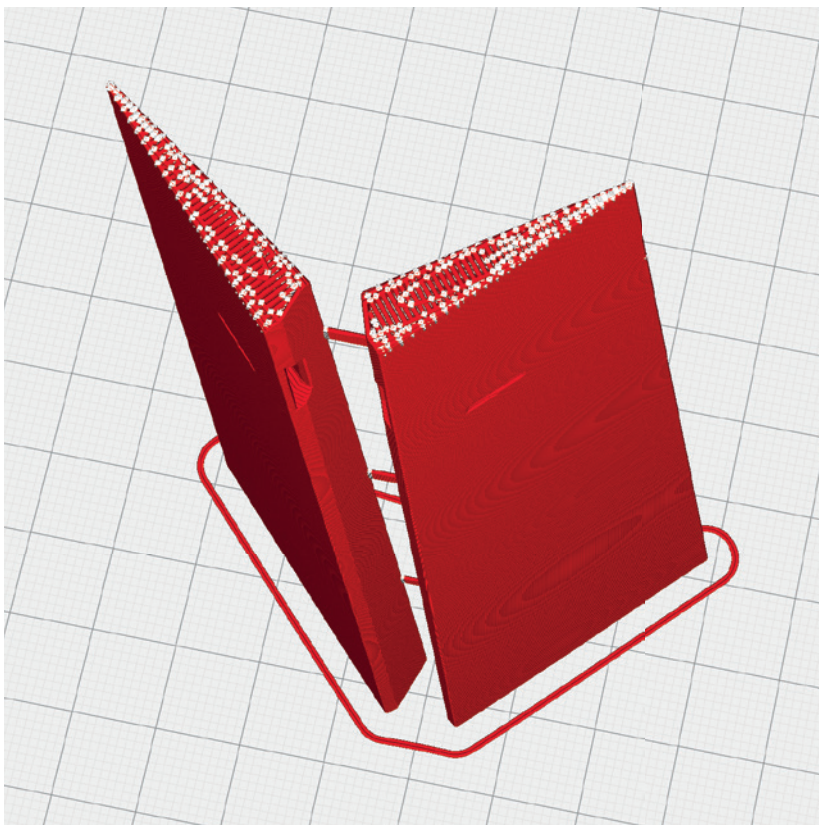

## fm\_Flap-left\_profile3.stl fm\_Flap-right\_profile3.stl

**MATERIAL** PLA, ~ 22 g

### ADDITIONAL SETTINGS

None required

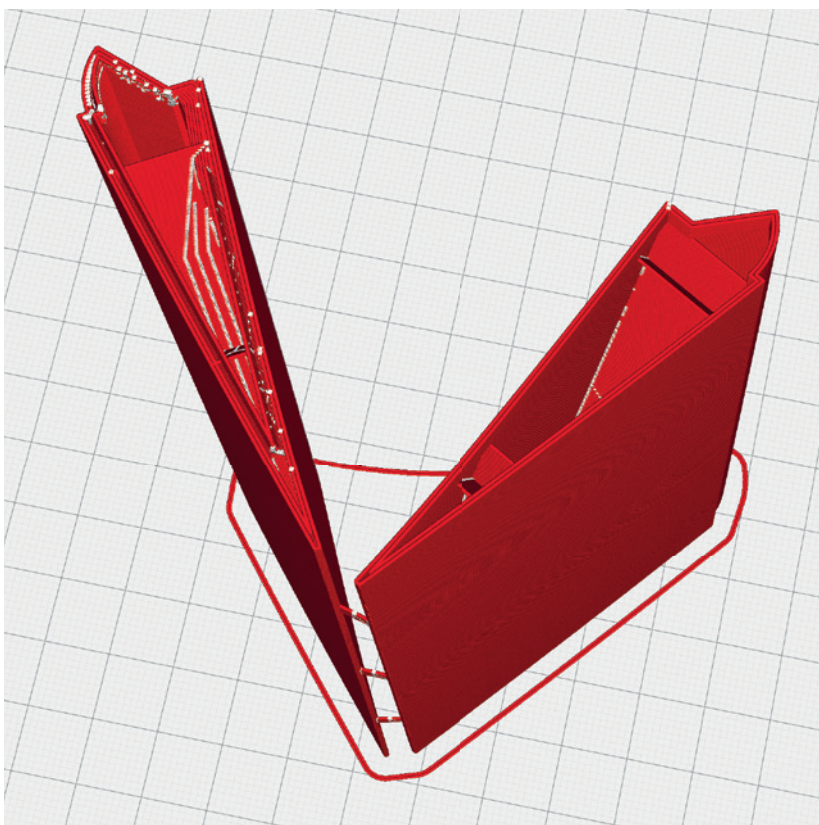

# PROFILE P3\_SURFACE

The following parts must be sliced with the PROFILE P3\_SURFACE (1-wall-print).

**Please note the additional settings for the individual parts!**

**PLEASE NOTE** In profile P3\_SURFACE, there should not be more than one STL on the buildplate at the same time, otherwise slicing errors can occur! Depending on your printer, a brim may not be required.

## fm\_Fuselage 1\_profile3.stl

**MATERIAL** PLA, ~ 65 g

**ADDITIONAL SETTINGS**

None required

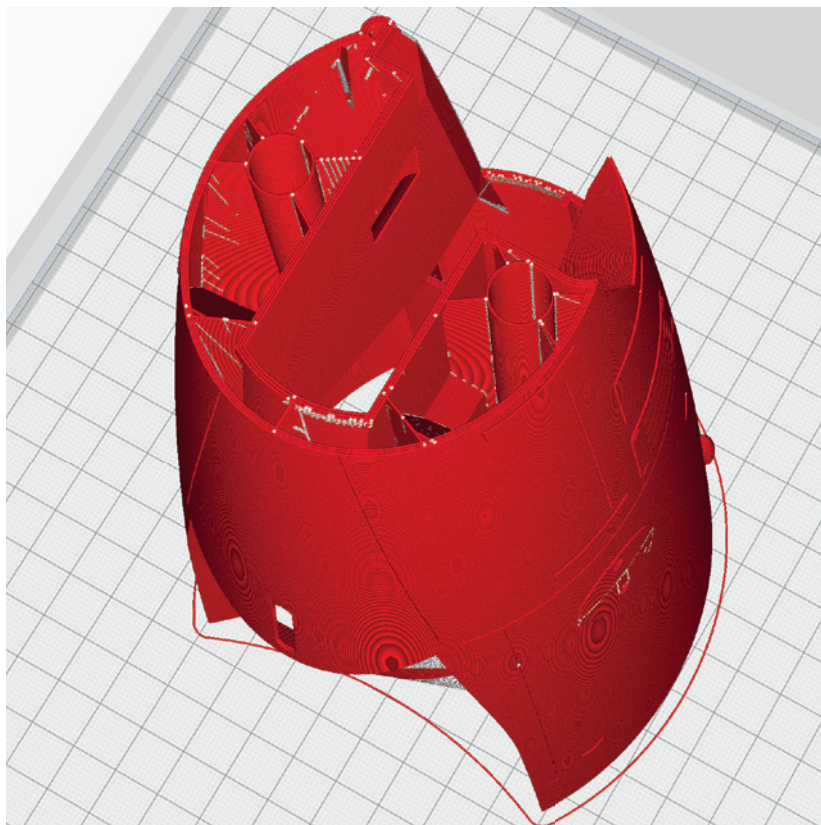

## fm\_Fuselage 2\_profile3.stl

**MATERIAL** PLA, ~ 84 g

**ADDITIONAL SETTINGS**

None required

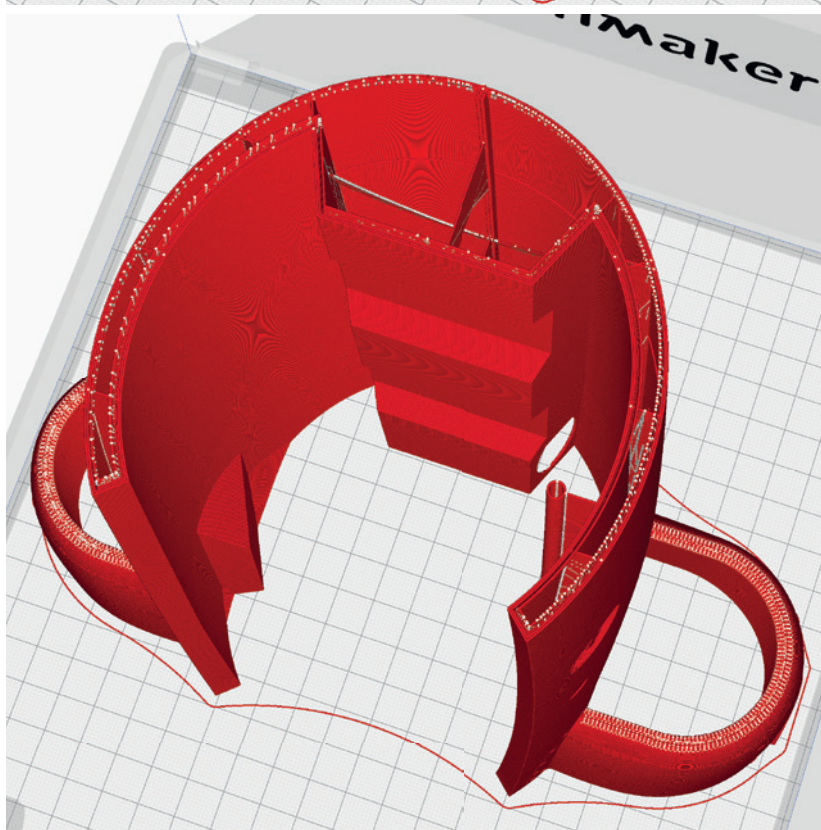

# PROFILE P3\_SURFACE

The following parts must be sliced with the PROFILE P3\_SURFACE (1-wall-print).

**Please note the additional settings for the individual parts!**

**PLEASE NOTE** In profile P3\_SURFACE, there should not be more than one STL on the buildplate at the same time, otherwise slicing errors can occur! Depending on your printer, a brim may not be required.

## fm\_Fuselage 3\_profile3.stl

**MATERIAL** PLA, ~ 95 g

### ADDITIONAL SETTINGS

None required

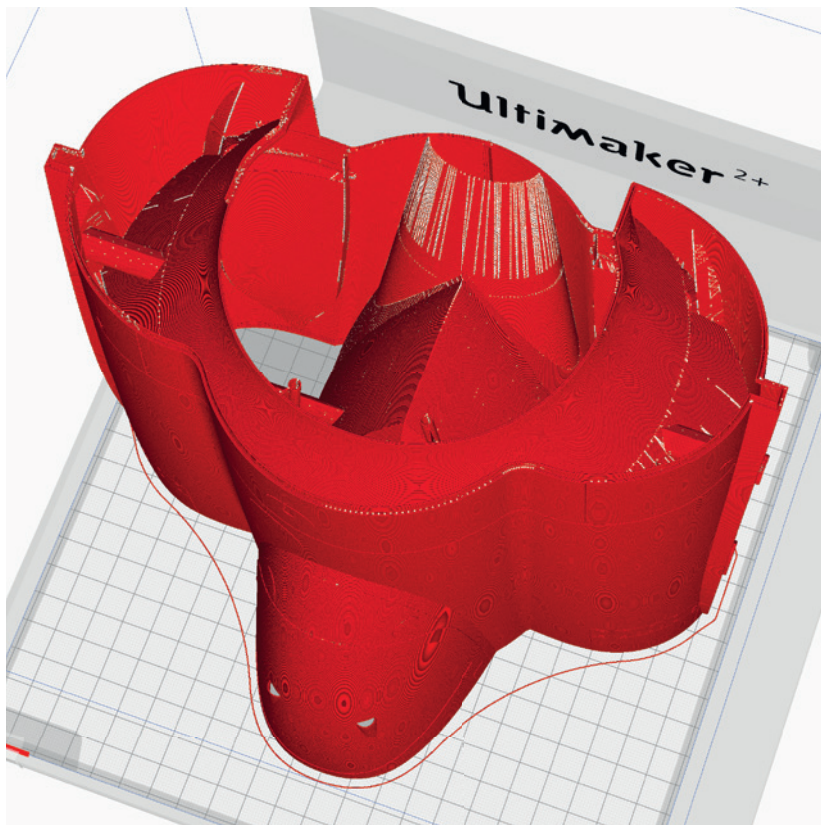

## fm\_Fuselage 4\_profile3.stl

**MATERIAL** PLA, ~ 82 g

### ADDITIONAL SETTINGS

None required

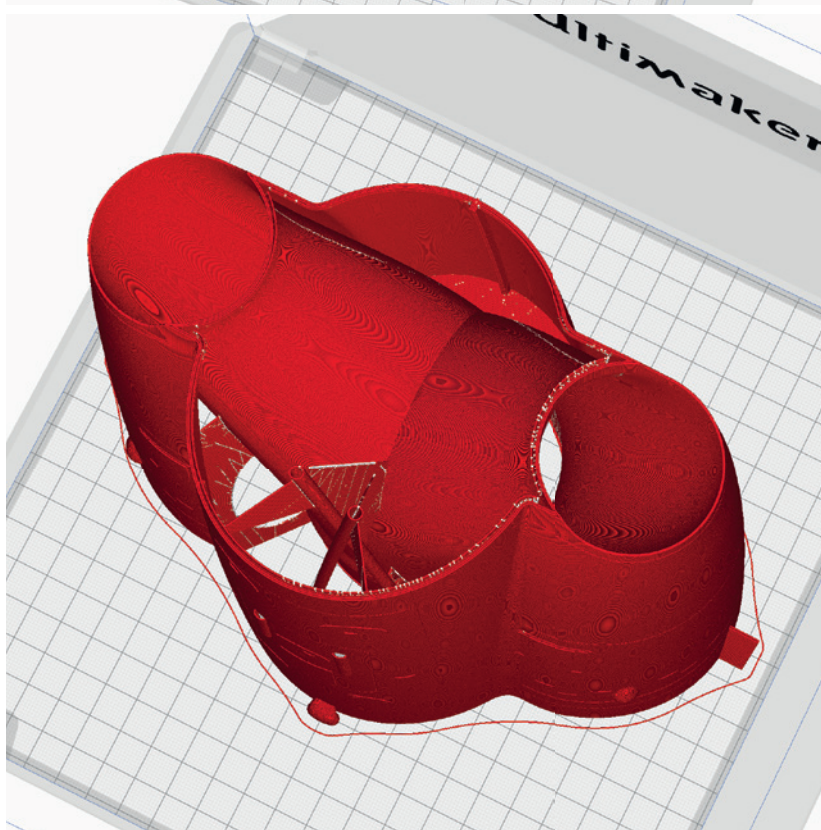

# PROFILE P3\_SURFACE

The following parts must be sliced with the PROFILE P3\_SURFACE (1-wall-print).

**Please note the additional settings for the individual parts!**

**PLEASE NOTE** In profile P3\_SURFACE, there should not be more than one STL on the buildplate at the same time, otherwise slicing errors can occur! Depending on your printer, a brim may not be required.

## fm\_Fuselage 5\_profile3.stl

**MATERIAL** PLA, ~ 34 g

### ADDITIONAL SETTINGS

None required

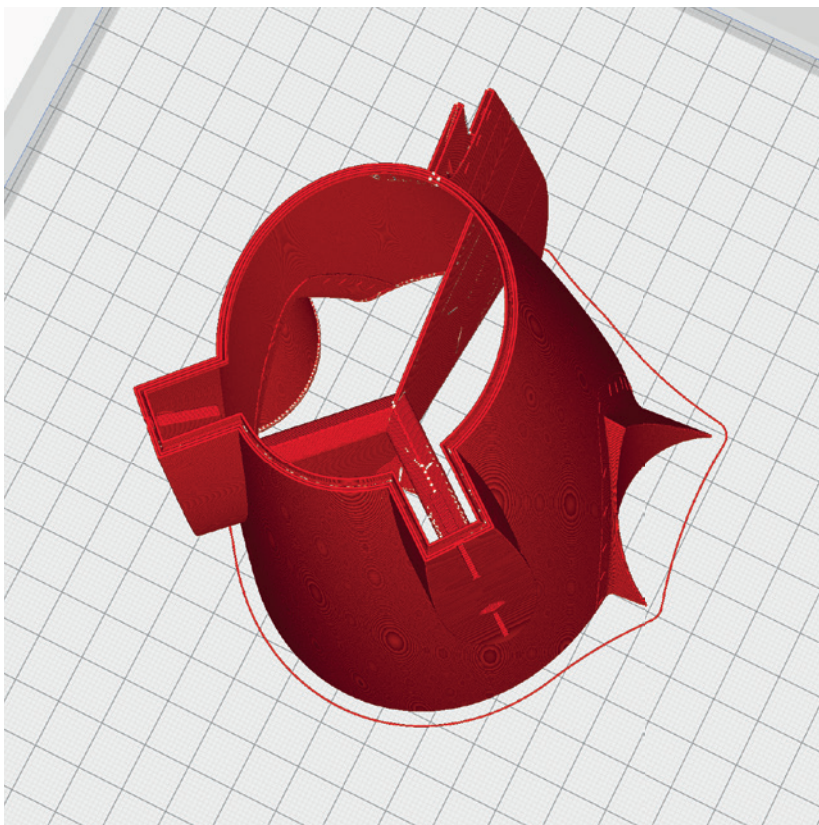

## fm\_Fuselage 6\_profile3.stl

**MATERIAL** PLA, ~ 7 g

### ADDITIONAL SETTINGS

None required

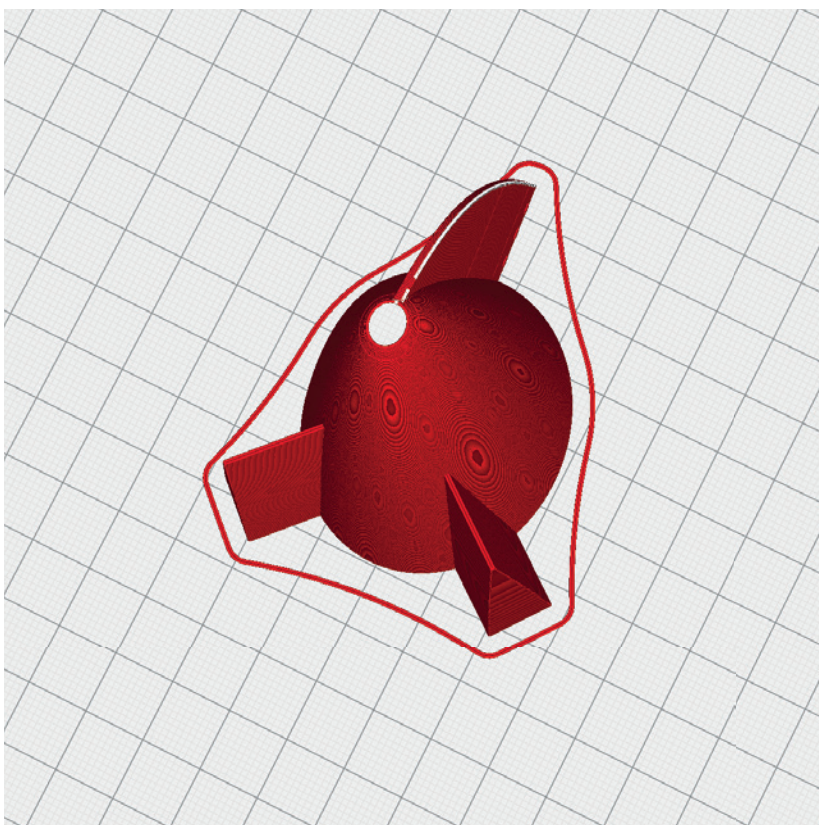

# PROFILE P3\_SURFACE

The following parts must be sliced with the PROFILE P3\_SURFACE (1-wall-print).

**Please note the additional settings for the individual parts!**

**PLEASE NOTE** In profile P3\_SURFACE, there should not be more than one STL on the buildplate at the same time, otherwise slicing errors can occur! Depending on your printer, a brim may not be required.

## fm\_Nose\_profile3.stl

**MATERIAL** PLA, ~ 14 g

### ADDITIONAL SETTINGS

None required

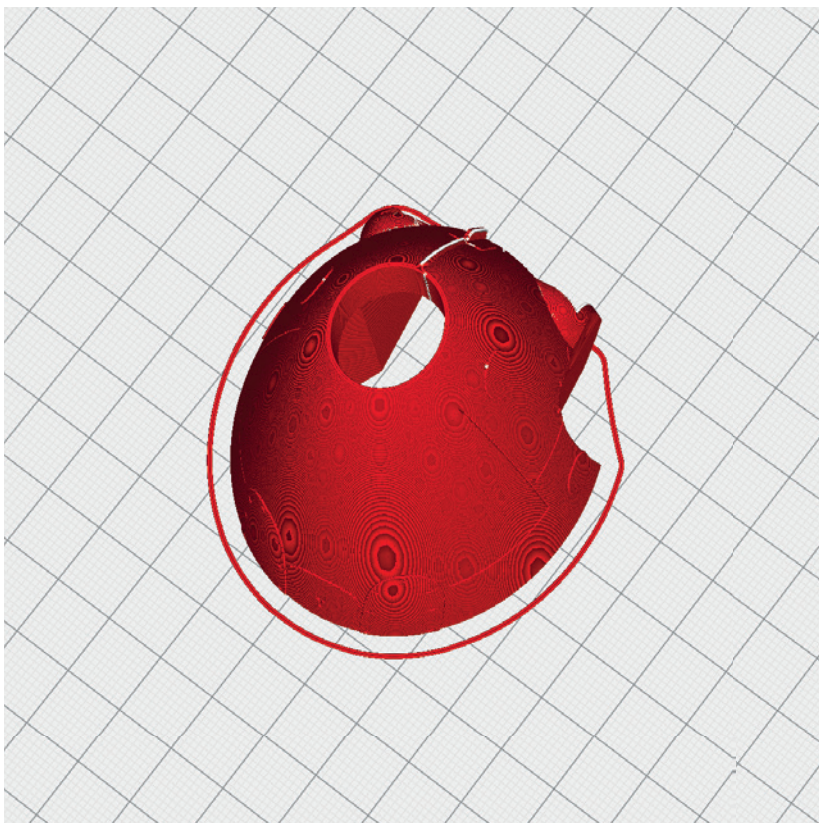

## fm\_Stabilizer 1-left\_profile3.stl fm\_Stabilizer 1-right\_profile3.stl

**MATERIAL** PLA, ~ 21 g

### ADDITIONAL SETTINGS

None required

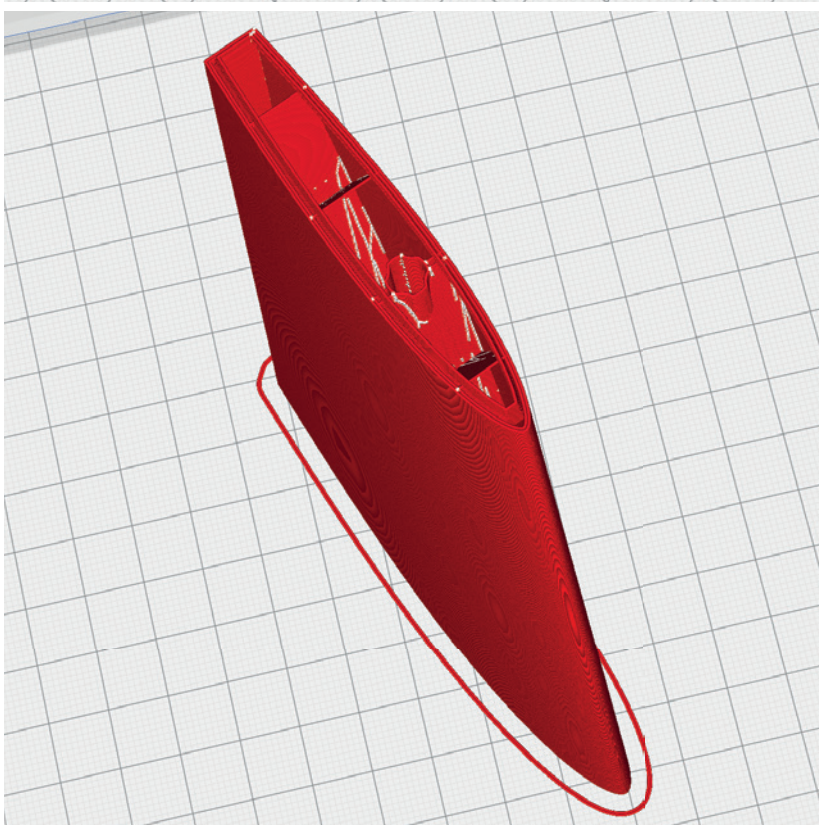

# PROFILE P3\_SURFACE

The following parts must be sliced with the PROFILE P3\_SURFACE (1-wall-print).

**Please note the additional settings for the individual parts!**

**PLEASE NOTE** In profile P3\_SURFACE, there should not be more than one STL on the buildplate at the same time, otherwise slicing errors can occur! Depending on your printer, a brim may not be required.

fm\_Stabilizer 2-left\_profile3.stl  
fm\_Stabilizer 2-right\_profile3.stl

**MATERIAL** PLA, ~ 12 g

**ADDITIONAL SETTINGS**

None required

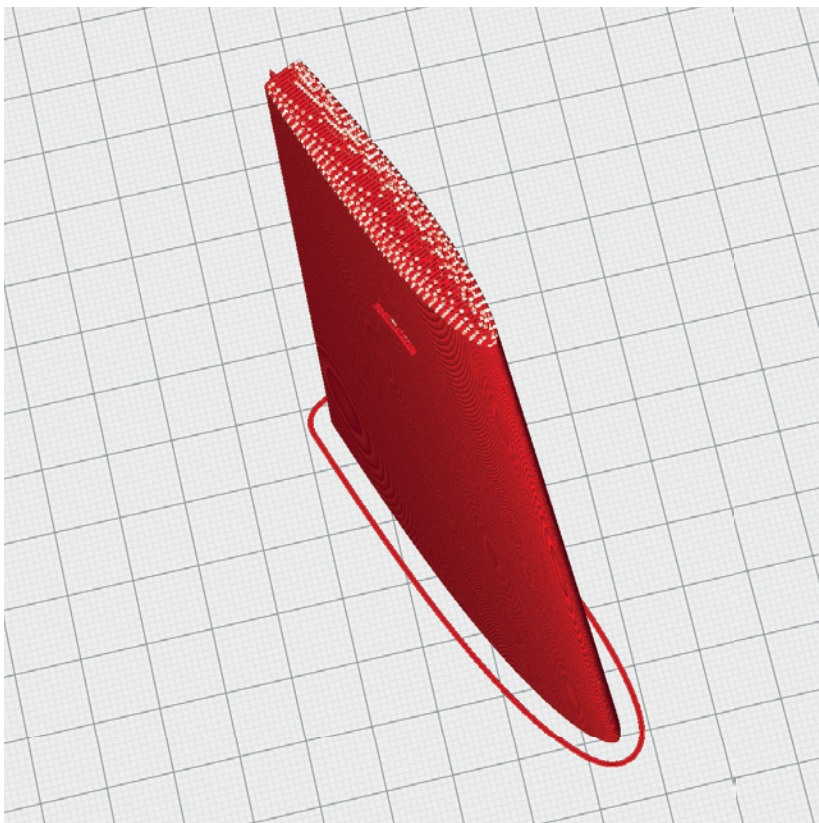

fm\_Wing 1-left\_profile3.stl  
fm\_Wing 1-right\_profile3.stl

**MATERIAL** PLA, ~ 54 g

**ADDITIONAL SETTINGS**

None required

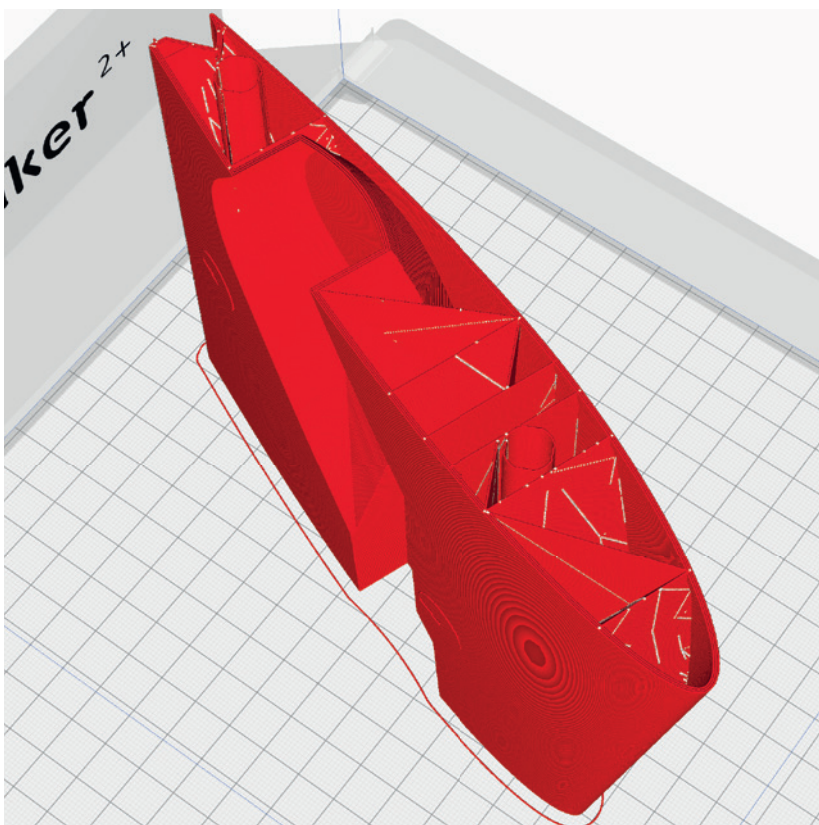

# PROFILE P3\_SURFACE

The following parts must be sliced with the PROFILE P3\_SURFACE (1-wall-print).

**Please note the additional settings for the individual parts!**

**PLEASE NOTE** In profile P3\_SURFACE, there should not be more than one STL on the buildplate at the same time, otherwise slicing errors can occur! Depending on your printer, a brim may not be required.

fm\_Wing 2-left\_profile3.stl  
fm\_Wing 2-right\_profile3.stl

**MATERIAL** PLA, ~ 43 g

**ADDITIONAL SETTINGS**

None required

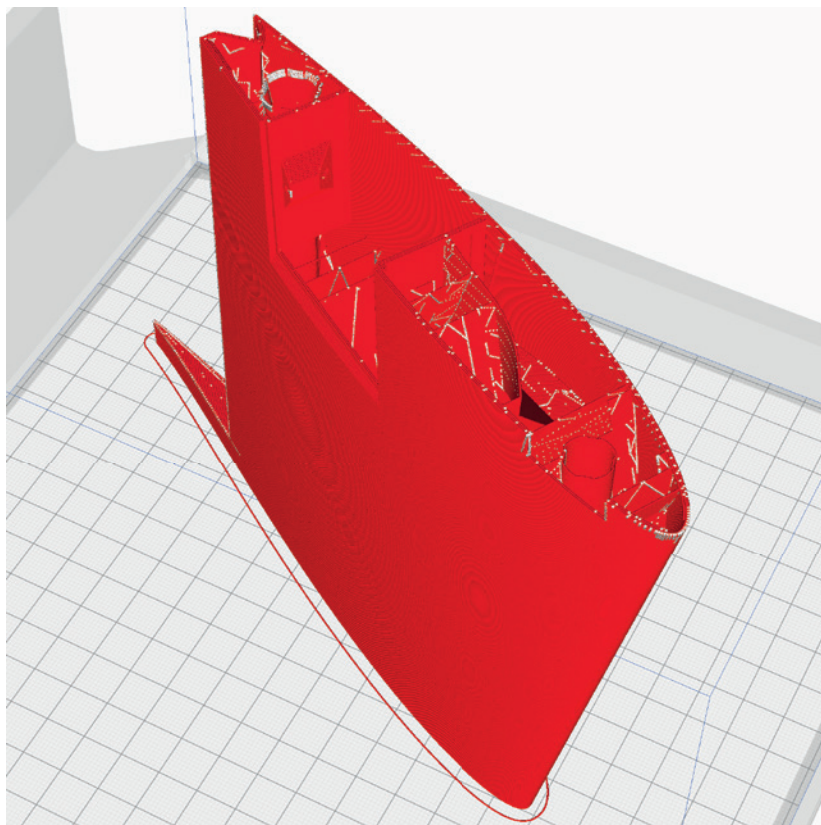

fm\_Wing 3-left\_profile3.stl  
fm\_Wing 3-right\_profile3.stl

**MATERIAL** PLA, ~ 34 g

**ADDITIONAL SETTINGS**

None required

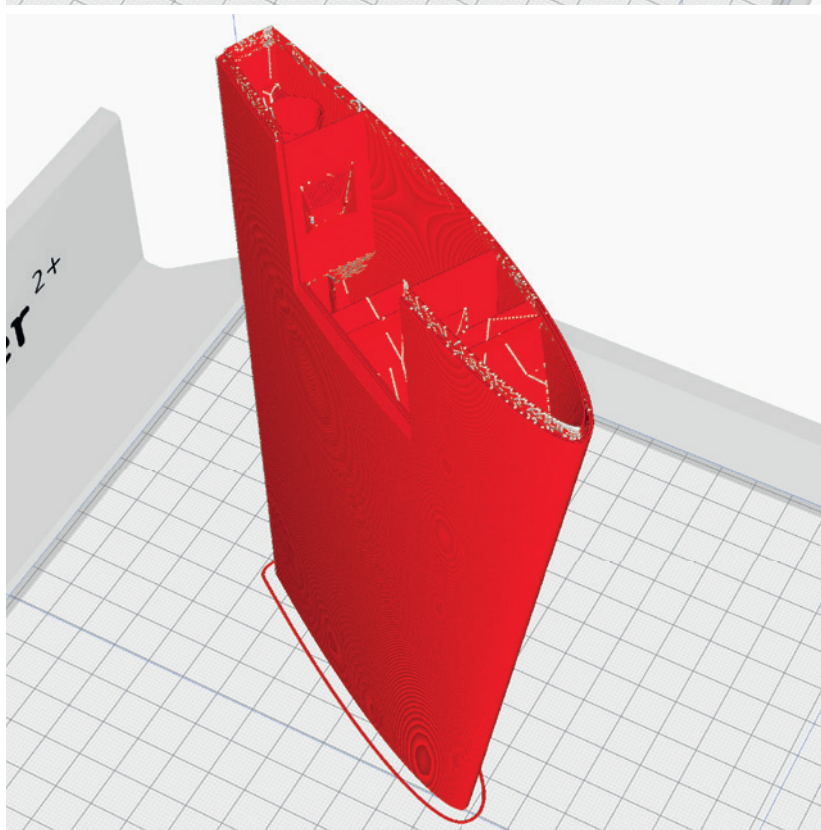

# PROFILE P3\_SURFACE

The following parts must be sliced with the PROFILE P3\_SURFACE (1-wall-print).

**Please note the additional settings for the individual parts!**

**PLEASE NOTE** In profile P3\_SURFACE, there should not be more than one STL on the buildplate at the same time, otherwise slicing errors can occur! Depending on your printer, a brim may not be required.

fm\_Wing 4-left\_profile3.stl  
fm\_Wing 4-right\_profile3.stl

**MATERIAL** PLA, ~ 10 g

**ADDITIONAL SETTINGS**

None required

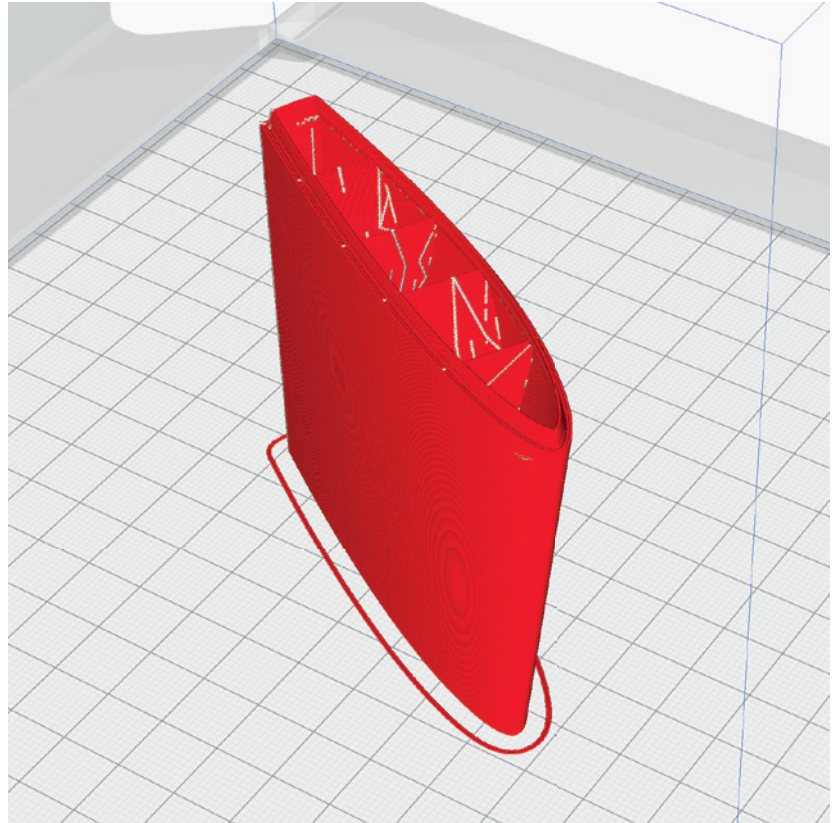

fm\_Wingtip-left\_profile3.stl  
fm\_Wingtip-right\_profile3.stl

**MATERIAL** PLA, ~ 16 g

**ADDITIONAL SETTINGS**

None required

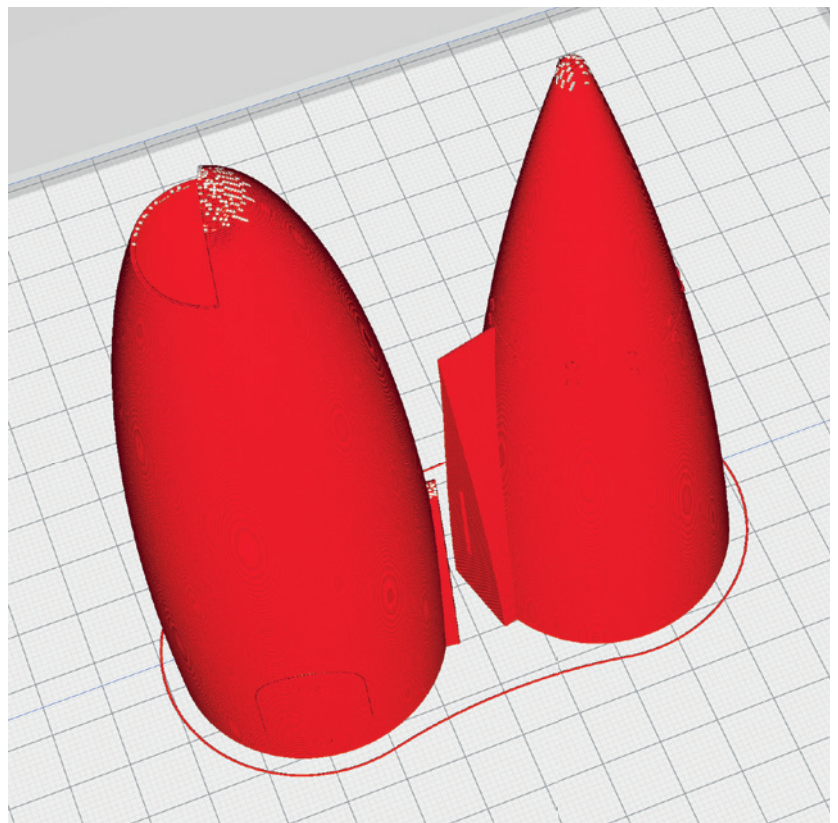

# PROFILE P3\_SURFACE

The following parts must be sliced with the PROFILE P3\_SURFACE (1-wall-print).

**Please note the additional settings for the individual parts!**

**PLEASE NOTE** In profile P3\_SURFACE, there should not be more than one STL on the buildplate at the same time, otherwise slicing errors can occur! Depending on your printer, a brim may not be required.

fm\_EDF-Cover\_profile3.stl

**MATERIAL** PLA, ~ 10 g

**ADDITIONAL SETTINGS**

- 30 % Fan

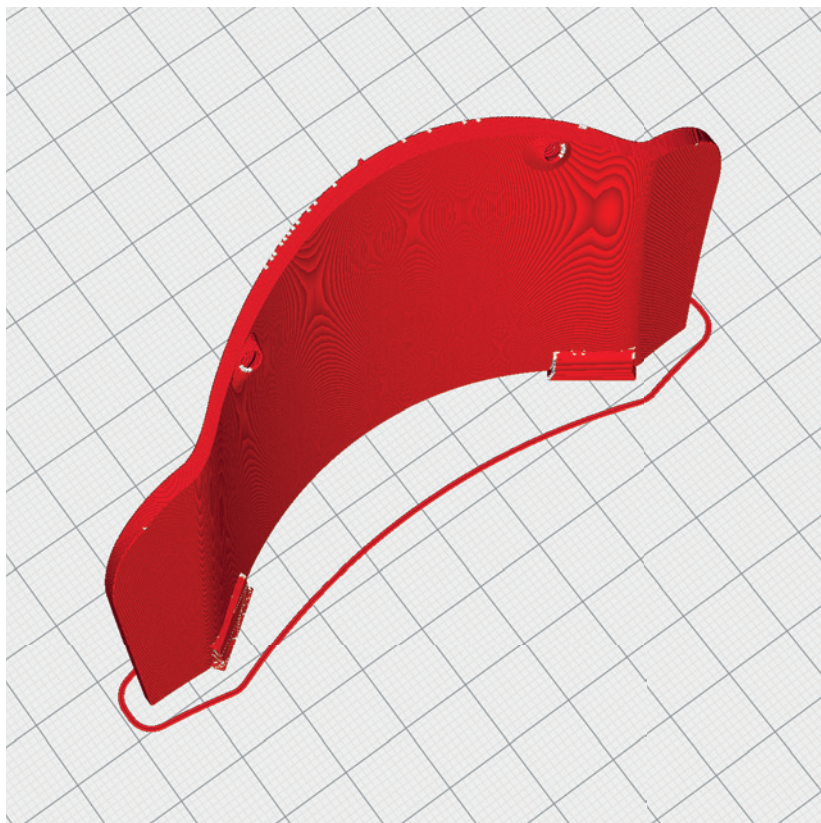

# PROFILE P4\_FLEX

The following parts must be sliced with the PROFILE P4\_FLEX.  
Please note the additional settings for the individual parts!

**MATERIAL** We recommend varioShore TPU from Colorfabb!

## fm\_Gear-flex\_profile4.stl

**MATERIAL** LW-TPU varioShore Flow 70 %  
Weight: ~ 3 g

The suspension works best with Colorfabb's soft varioShore. Alternatively, it can also be printed with TPU A95.

### ADDITIONAL SETTINGS

- Wall Line Count: 5

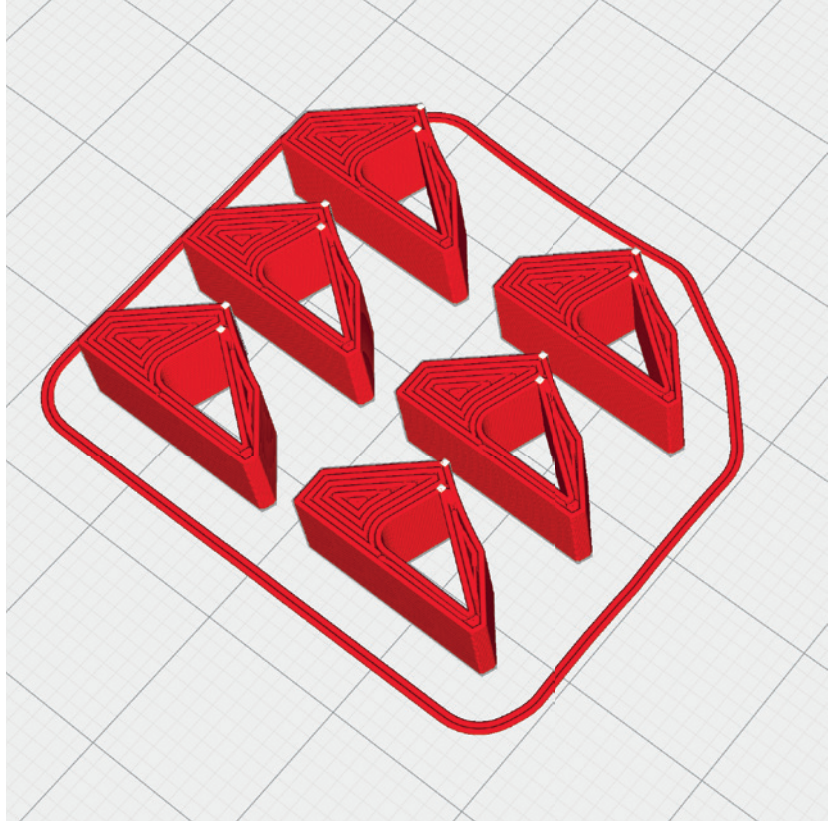

## fm\_Hinges\_profile4.stl

**MATERIAL** LW-TPU varioShore Flow 100 %  
Weight: ~ 3 g

Or normal TPU A95.

### ADDITIONAL SETTINGS

None required

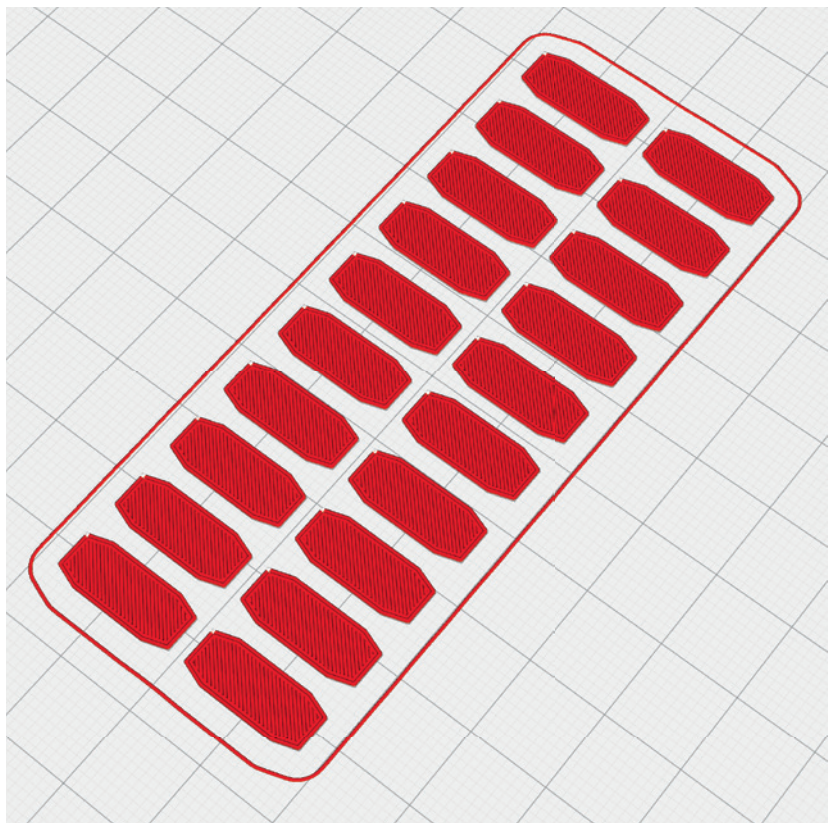

# PROFILE P4\_FLEX

The following parts must be sliced with the PROFILE P4\_FLEX.  
Please note the additional settings for the individual parts!

**MATERIAL** We recommend varioShore TPU from Colorfabb!

## fm\_Tire front\_profile4.stl

**MATERIAL** LW-TPU varioShore Flow 70 %  
Weight: ~ 8 g

The suspension works best with Colorfabb's soft varioShore. Alternatively, it can also be printed with TPU A95.

### ADDITIONAL SETTINGS

**varioShore with Flow 70 %:**

- Wall Line Count: 5
- Top Layers: 5
- Bottom Layers: 5
- Infill Density: 15 %
- Infill Pattern: Gyroid

**TPU A95:**

- Wall Line Count: 2
- Top Layers: 3
- Infill Pattern: Gyroid



## fm\_Tire\_profile4.stl

**MATERIAL** LW-TPU varioShore Flow 70 %  
Weight: ~ 17 g

The suspension works best with Colorfabb's soft varioShore. Alternatively, it can also be printed with TPU A95.

### ADDITIONAL SETTINGS

**varioShore with Flow 70 %:**

- Wall Line Count: 6
- Top Layers: 6
- Bottom Layers: 6
- Infill Density: 15 %
- Infill Pattern: Gyroid
- print twice

**TPU A95:**

- Wall Line Count: 3
- Top Layers: 3
- Infill Pattern: Gyroid

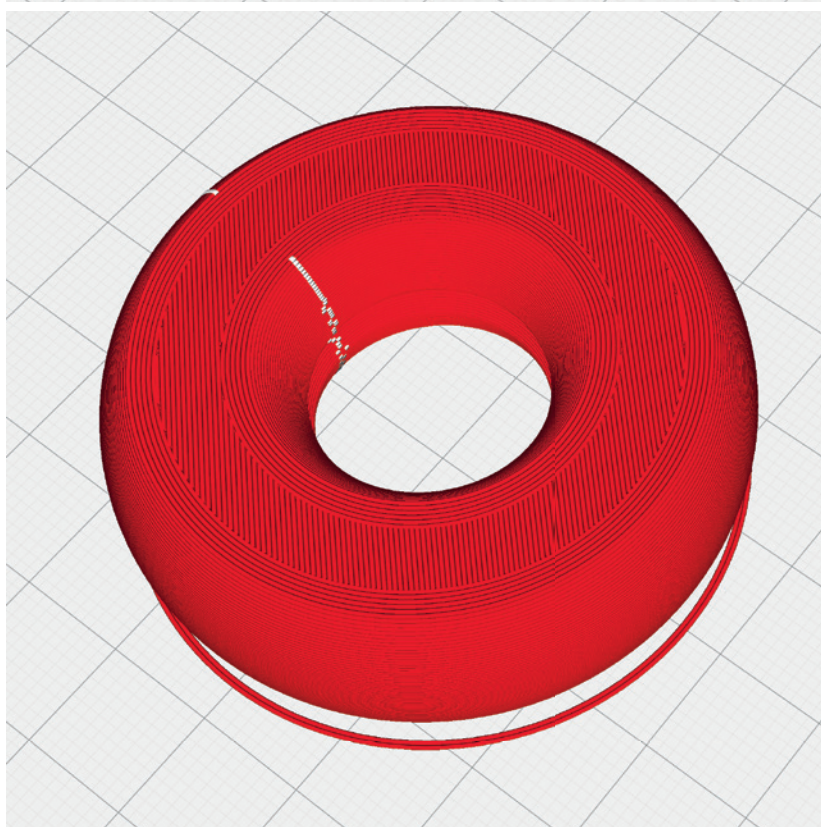

# PROFILE P4\_FLEX

The following parts must be sliced with the PROFILE P4\_FLEX.  
Please note the additional settings for the individual parts!

**MATERIAL** We recommend varioShore TPU from Colorfabb!

## fm\_Tire back\_profile4.stl

**MATERIAL** LW-TPU varioShore Flow 70 %  
Weight: ~ 8 g

The suspension works best with Colorfabb's soft varioShore. Alternatively, it can also be printed with TPU A95.

### ADDITIONAL SETTINGS

#### varioShore with Flow 70 %:

- Wall Line Count: 4
- Top Layers: 4
- Bottom Layers: 4
- Infill Density: 15 %
- Infill Pattern: Gyroid

#### TPU A95:

- Wall Line Count: 2
- Top Layers: 3
- Infill Pattern: Gyroid

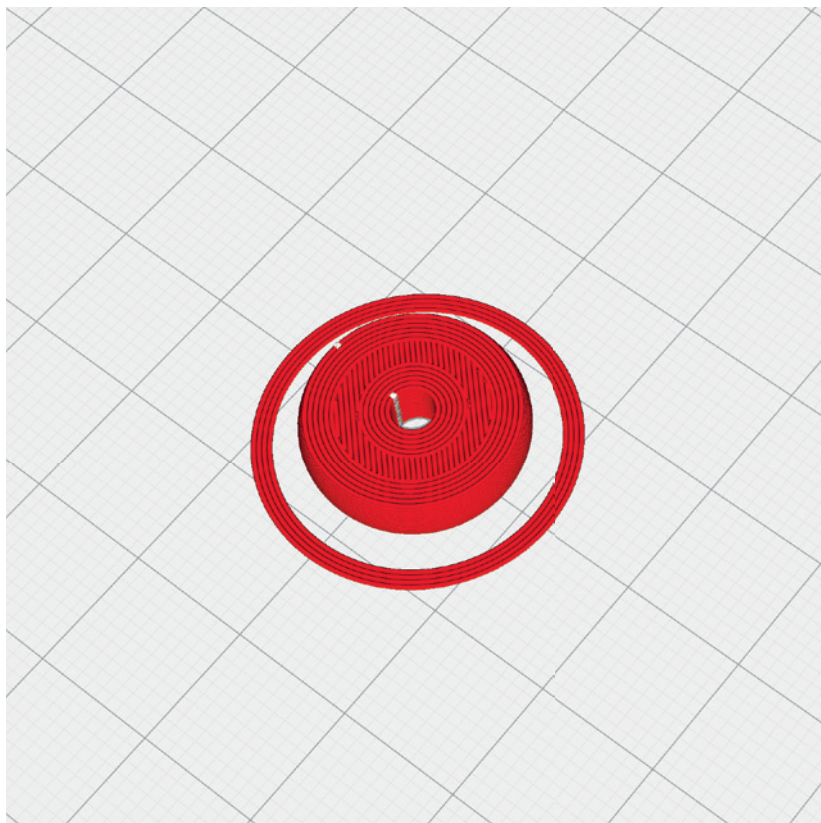

# REQUIRED ACCESSOIRES

## Filament

- normal PLA about 1500 grams
- LW-TPU varioShore (or TPU A95) about 50 grams

## Materials

- some tapping screws  $\varnothing 2 \times 8$  mm
- 3 Screws  $\varnothing 3 \times 22$  mm self-locking screw nuts for the wheels  
(**simply search for: M2 flat head tapping screw assortment**)
- CA super glue (liquid and liquid medium)
- CA activator
- Servo extension cables or cable for soldering
- Carbon tube  $\varnothing 8 \times 910$ mm (inside 6mm)
- Carbon tube  $\varnothing 8 \times 538$ mm (inside 6mm)
- Carbon rod  $\varnothing 4$ mm about 400mm
- Carbon rod  $\varnothing 1.5$ mm a small piece or something similar
- Steel wire  $\varnothing 3$ mm about 150mm
- Steel wire  $\varnothing 1$ mm, 2 pieces 700mm, 1 piece 400mm
- Rod connection, 9 pieces
- Self adhesive velcro tape
- 1 spring of a ballpoint pen



Rod connection

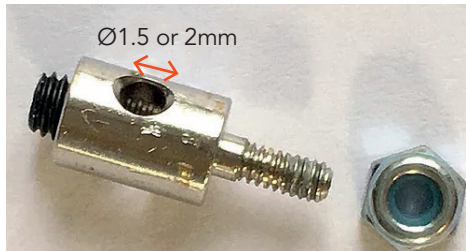

Carbon tube



Tapping screws



## Tools

- Cutter knife
- small Philips screwdriver
- Drill  $\varnothing 4$ mm,  $\varnothing 3$ mm,  $\varnothing 2,5$ mm,  $\varnothing 1,5$ mm
- Metal saw and metal file (or better a Dremel)

# RC Components

**ENGINE** EDF 70 mm, 4S or 6S We use the FMS 70

**BEC-CONTROLLER** suitable for your EDF

**RECEIVER** 9 Channel (recommended) or 8 Channel if the flaps are controlled with a Y-cable

**BATTERY** 4S or 6S LiPo-Akku

**SERVOS** Hitec HS-5055MG or (or similar in the same size), 7 pieces

**RETRACTION GEAR** 2x Servoless Retraction Gear small (32mm x 25mm)  
1x Servoless Retraction Nose-Gear small

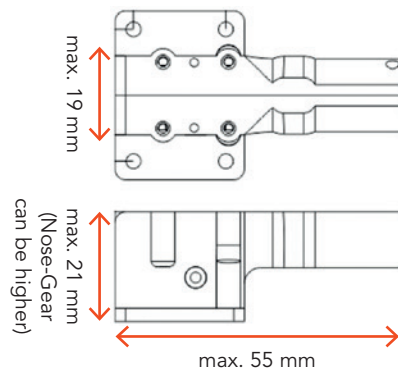

# BASIC INFORMATION

## Gluing the parts

To glue the fuselage and wing parts well, **use medium-liquid CA adhesive**.

First check whether the parts go well together. Then apply a lot of CA glue to the part with the connections and all surfaces that will touch later (except the bowden tubes). Put the parts together and align the parts perfectly. If glue comes out, wipe with a cloth. Then spray activator spray on the glue points.

**IMPORTANT** For a strong connection, the adhesive surfaces should be sanded. Please only use fresh CA glue and activator spray for curing! The adhesive connections must hold perfectly!

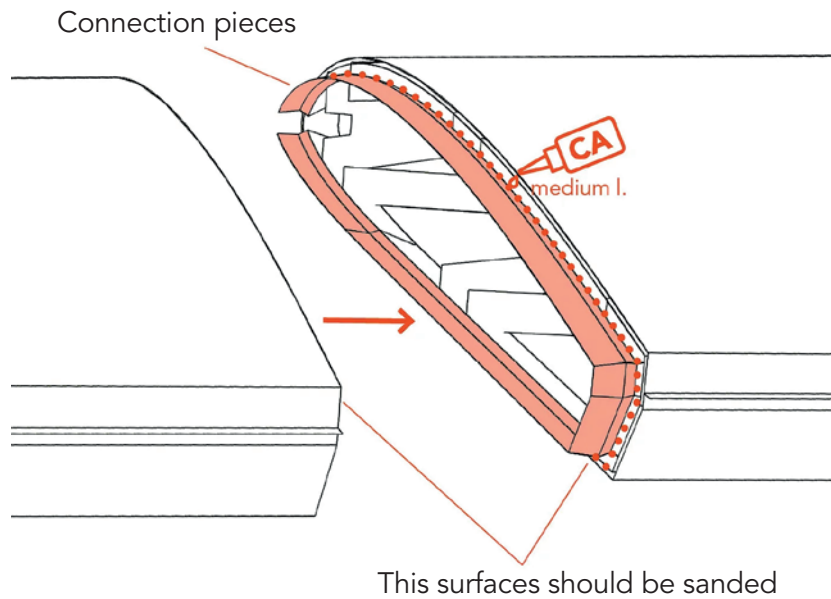

## Installation of the TPU hinges

First insert the hinge into the movable flap and add a drop of liquid CA adhesive into the gap. Wait for the glue to drain completely, then spray the activator on it.

Then put the flap in the wing until the flap touches the spacers and put a drop of CA glue on the hinge. Wait again for the glue to run in, and then spray the activator on it.

**Do not use too much glue, the flap must move easily!**

These spacers ensure the correct gap distance. Don't remove!

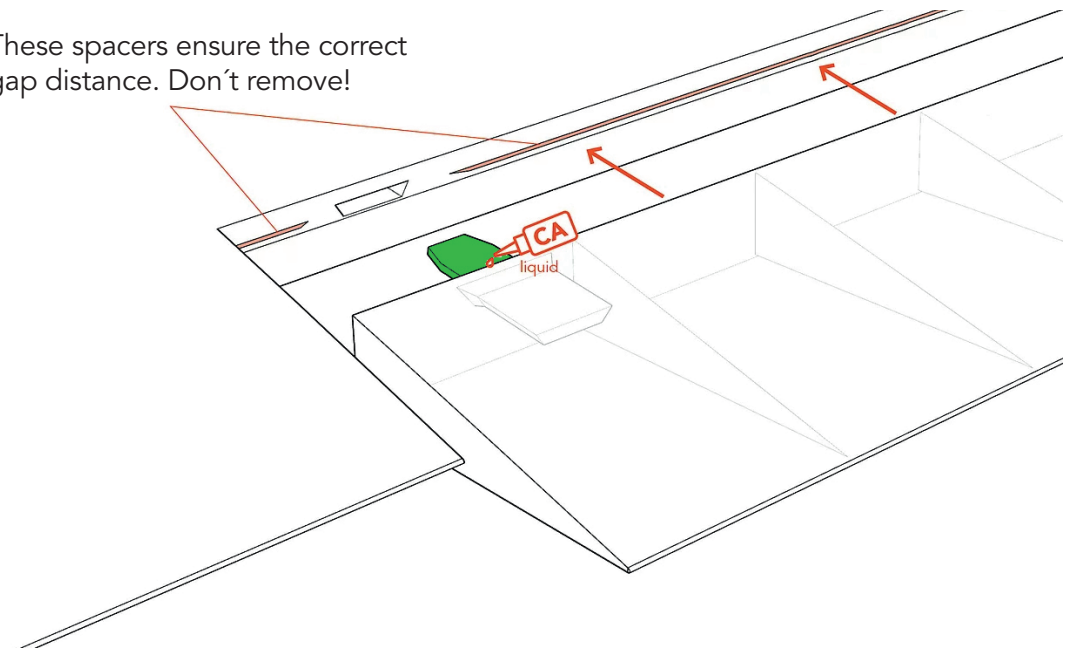

# ASSEMBLY INSTRUCTIONS

First remove the support with the cutter knife.  
You can also break out some support parts by hand.

**NOTE** Please be careful with the knife!

fm\_Nose\_profile3.stl

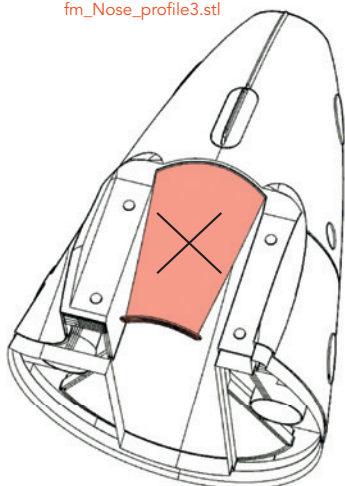

fm\_Fuselage 1\_profile3.stl

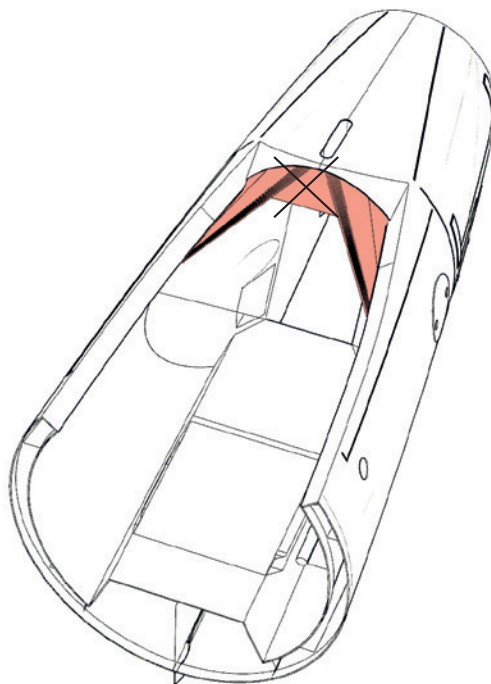

fm\_Fuselage 3\_profile3.stl

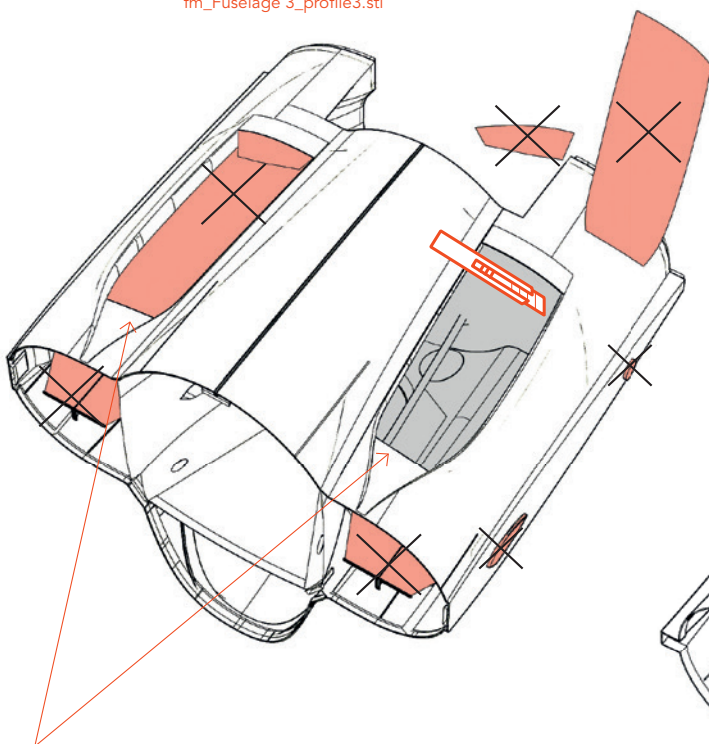

**Fuselage 3:** Carefully open the additional air inlets on the underside. Cut along the edge several times with little pressure, then you can simply break it out.

fm\_Fuselage 4\_profile3.stl

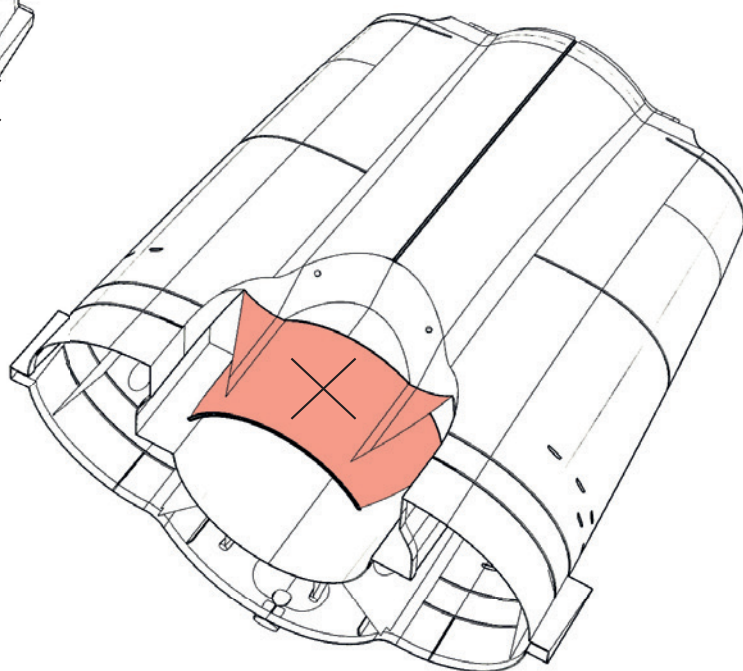

Instructions see at basic information

Start with STEP 1: Glue the interconnects in fuselage 3. Then put enough glue on Fuselage 2 (not on the interconnects) and put the parts together.

**IMPORTANT** First put all interconnects only a little bit into all slots and then join the parts with a quick movement, so that the glue does not set already during the pushing together.

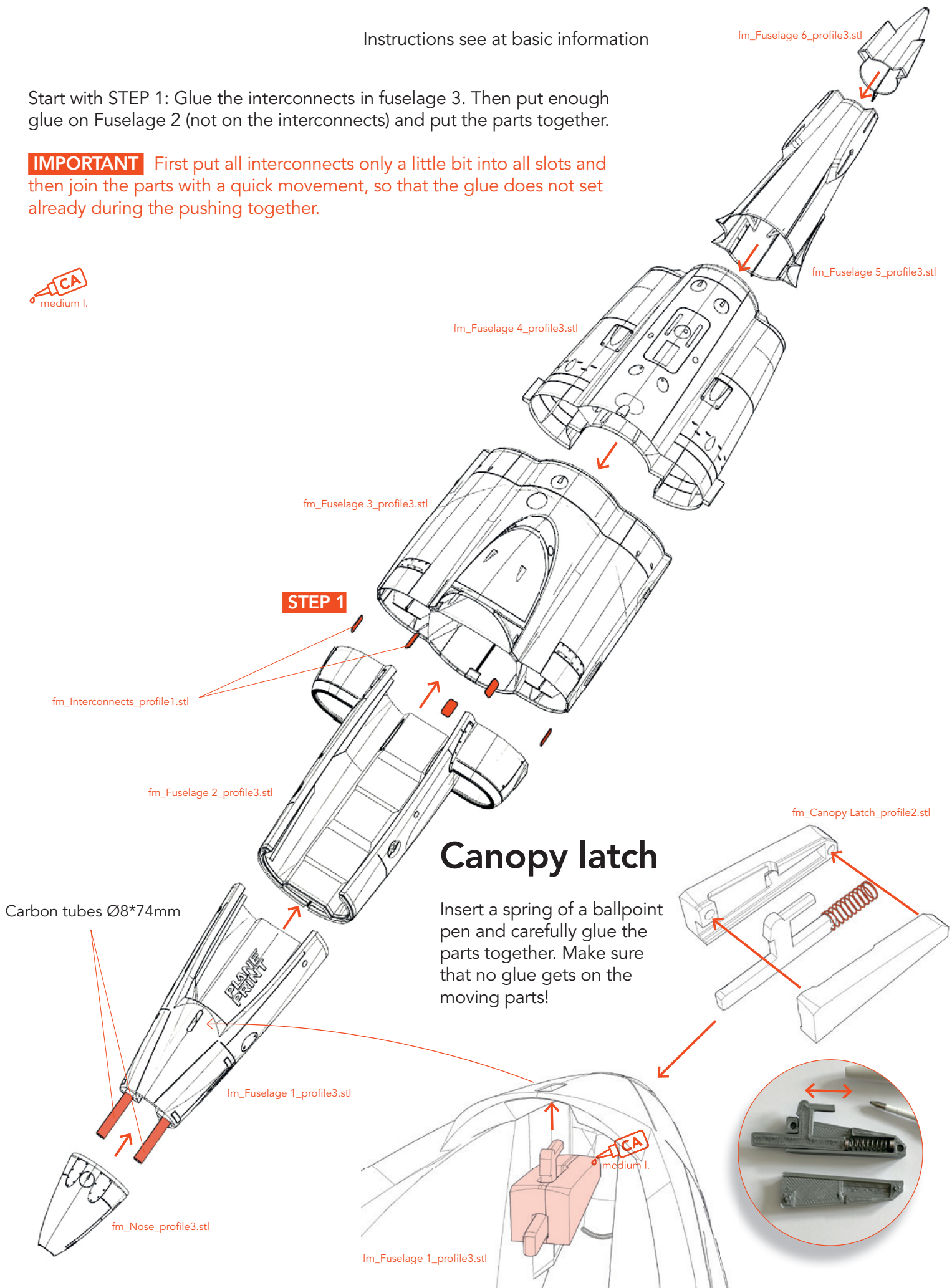

**STEP 1**

### Canopy latch

Insert a spring of a ballpoint pen and carefully glue the parts together. Make sure that no glue gets on the moving parts!

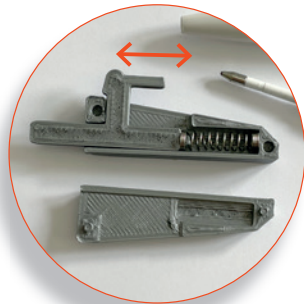

# Canopy

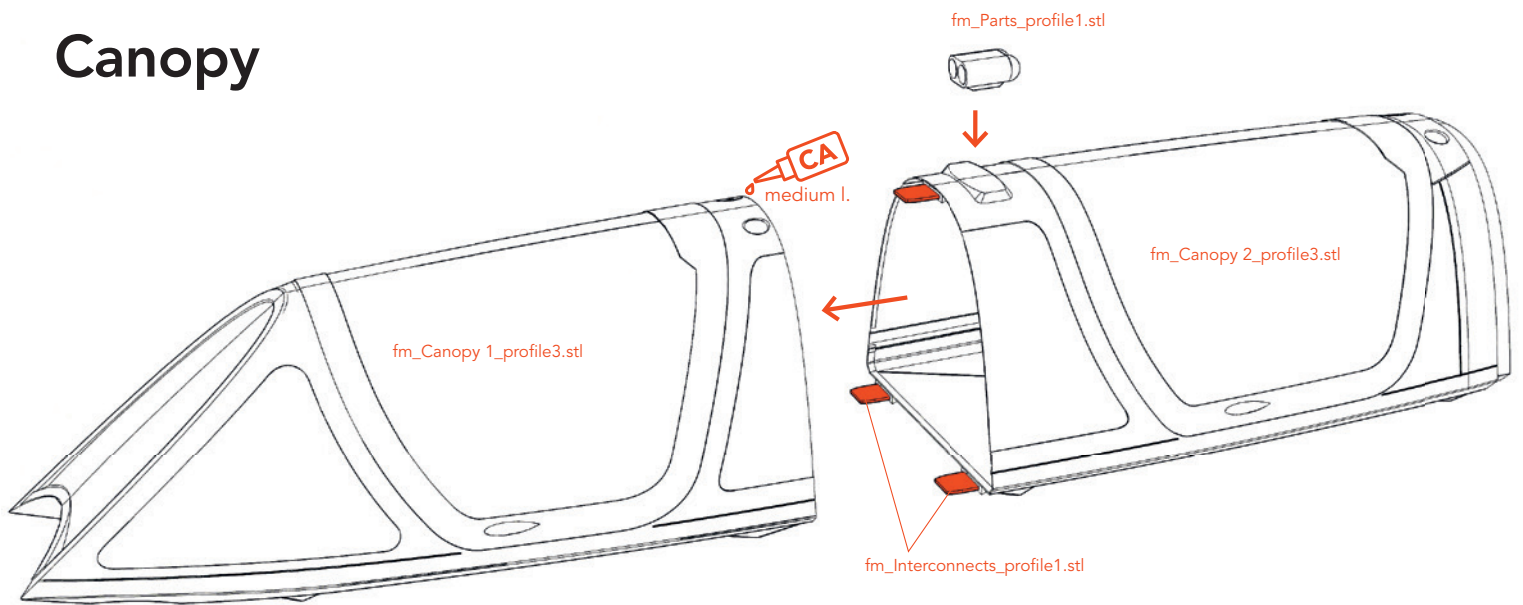

## Canopy clear view version

If you want to build the canopy as a **clear version**, you have to remove these fields carefully with the knife. It works best if you cut along the edges several times with little pressure and then carefully break out the window parts.

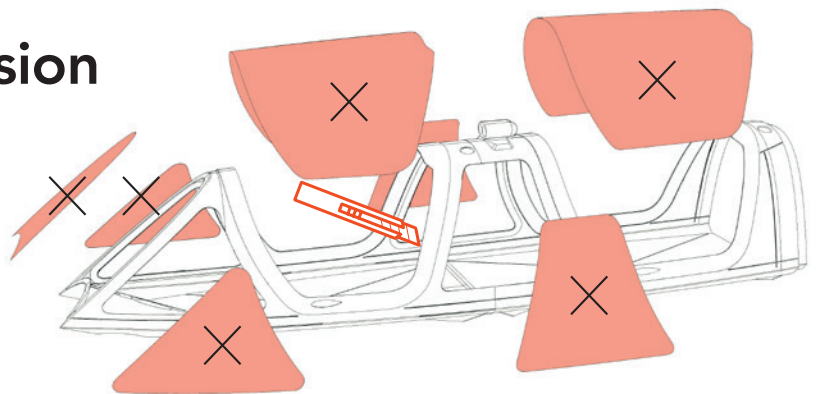

With the STL data you will find the PDF file **fm\_Canopyath.pdf** as a cutting template for the glass panes.

**IMPORTANT** the print must be set to 100% page size, so that the size fits exactly!

Suitable foils are overhead foils or binding covers of scripts (~0,2mm, office trade) in DIN A4 format.

Attach the template with tape behind the foil. Then stick narrow strips of double-sided tape on the white edges around the panes (keep some distance to the blue areas).

Then cut out the individual glass surfaces exactly along the black lines.

Then glue the foil parts from the inside into the canopy frame.

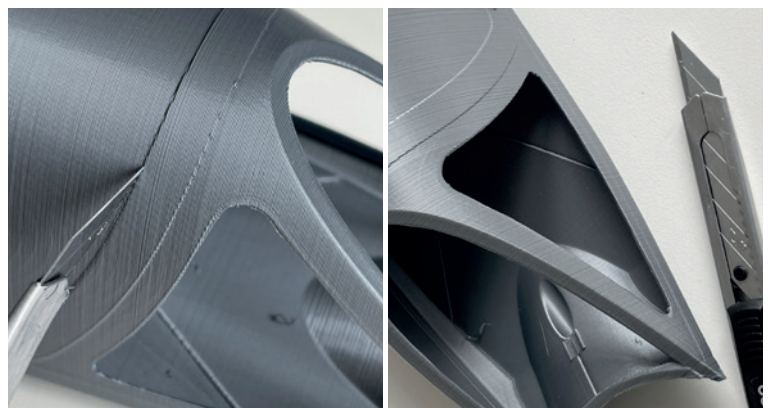
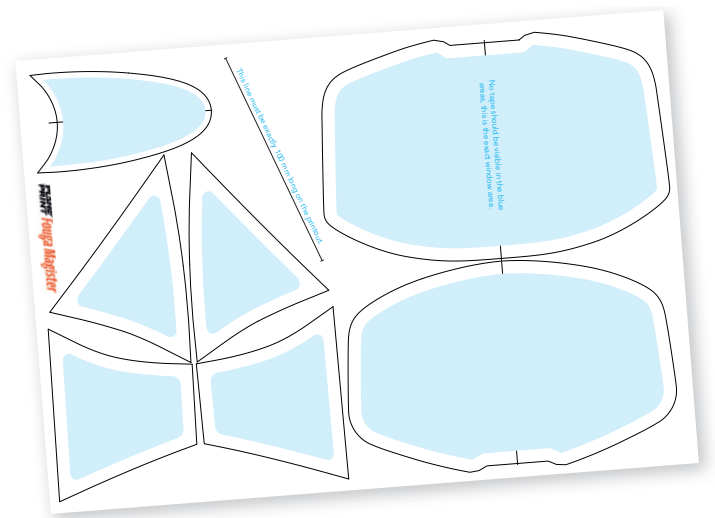

# Stabilizer assembly

First mount the stabilizers and the elevator, then glue them to the fuselage with the two carbon rods and interconnectors.

For the assembly of the hinges, see the basic information a few pages before.

**IMPORTANT** The elevator must remain easily movable!

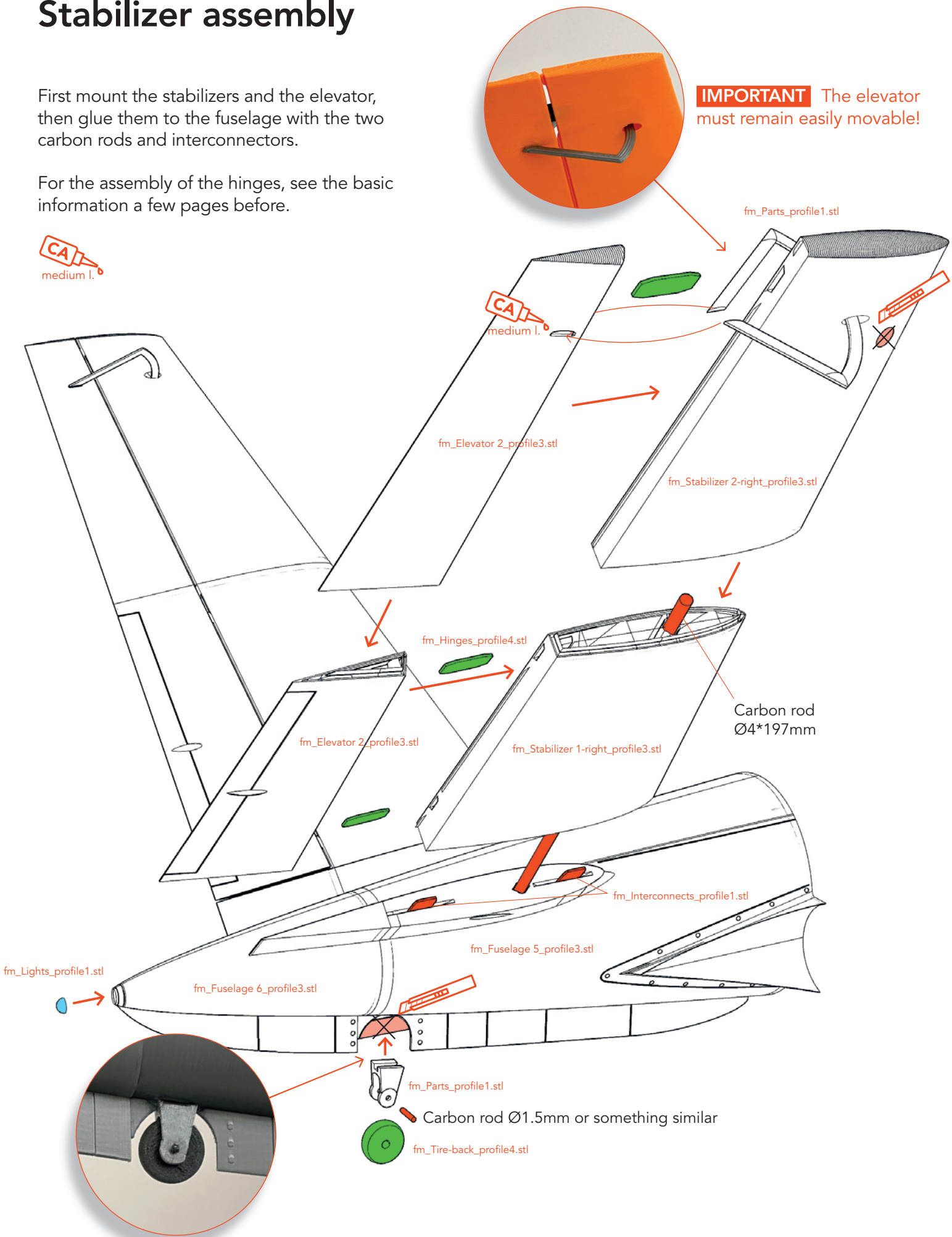

# Wings and Ailerons assembly

Instructions see at basic information

**IMPORTANT** The carbon tubes must NOT be glued!

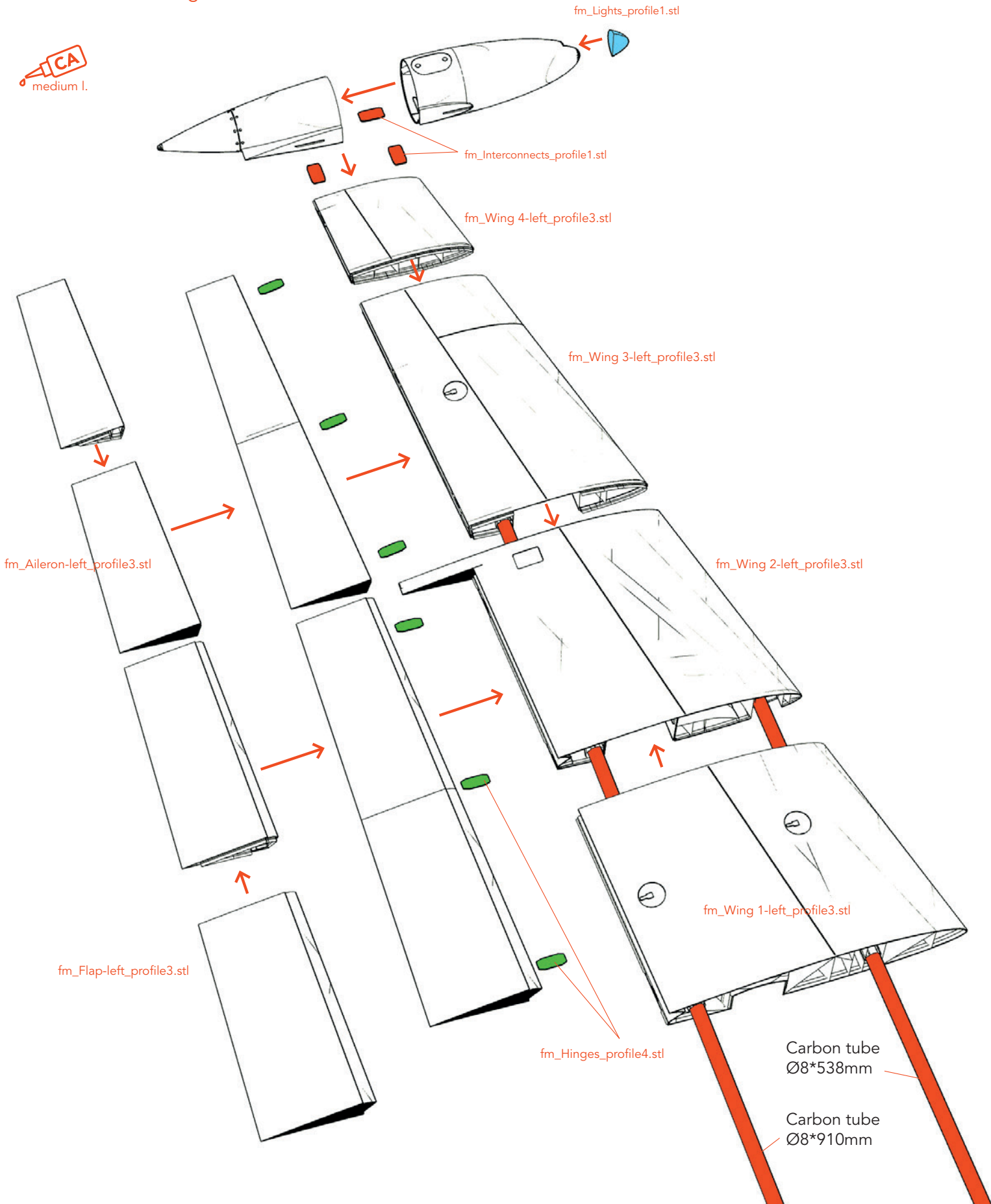

# Wing fastening

Insert the tube clamps without glue from below into the wing. Use an 8mm long self-tapping screw to prevent the wings from slipping off without damaging the carbon tube.

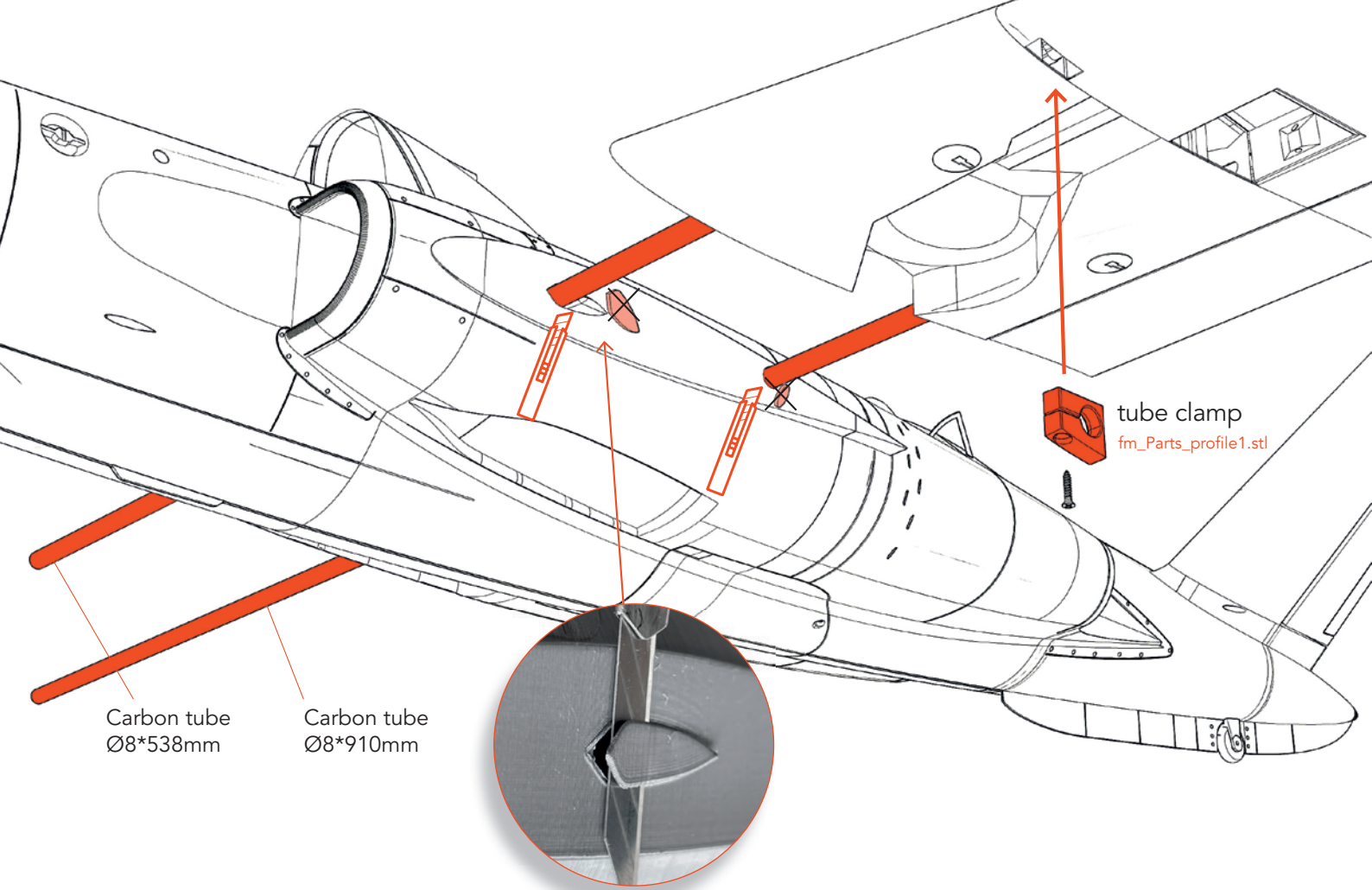

# Nose detail

Some fougas are equipped with brackets on the nose, if desired you can glue them to the marked areas.

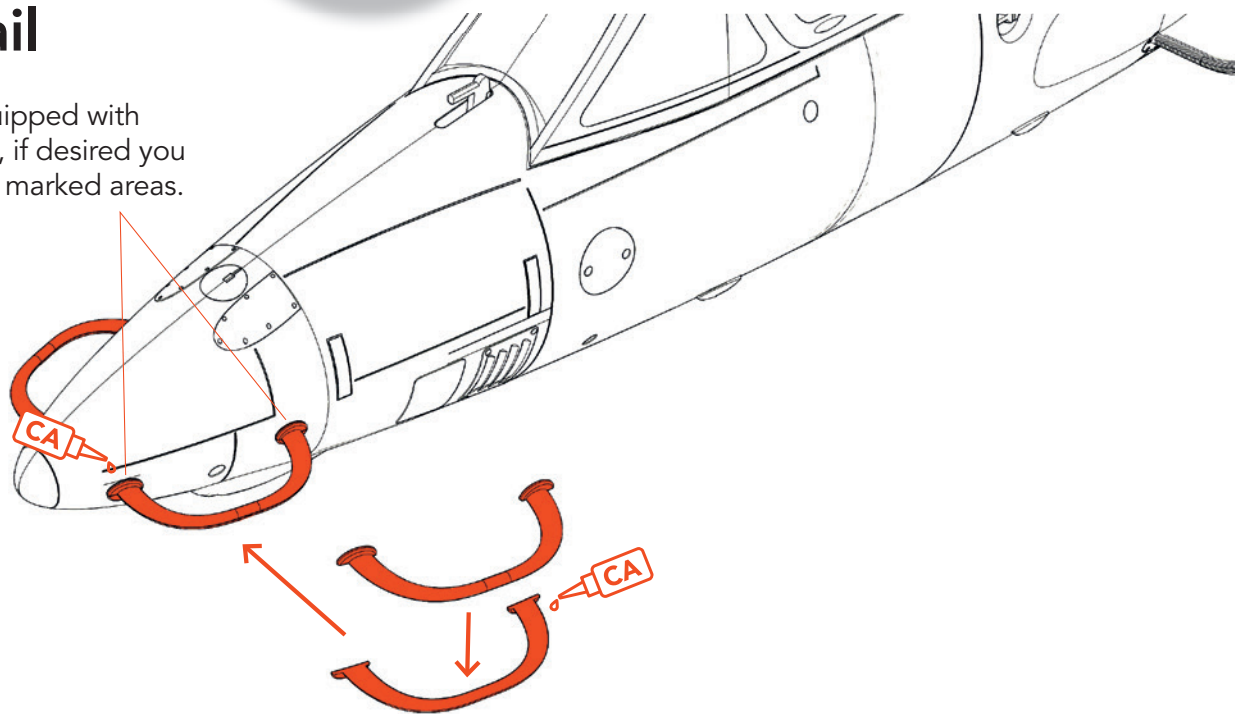

# Nose gear

Carefully tighten these screws. Since the PLA yields somewhat over time, these must be checked frequently so that the landing gear does not become loose. You can also glue in the steel wire.

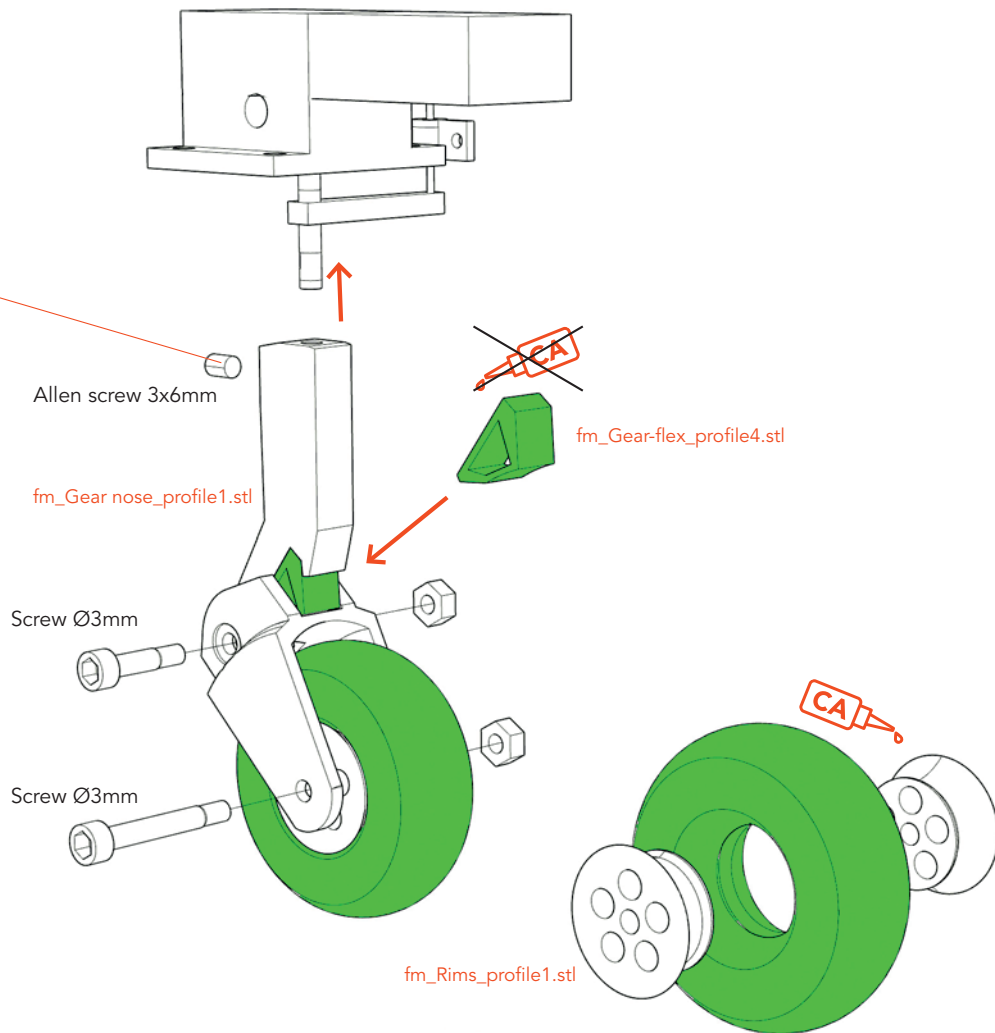

# Main gear

You need two Ø 3mm steel round bars. File flats at the indicated points.

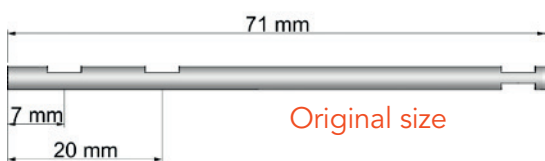

Carefully tighten these screws. Since the PLA yields somewhat over time, these must be checked frequently so that the landing gear does not become loose. You can also glue in the steel wire.

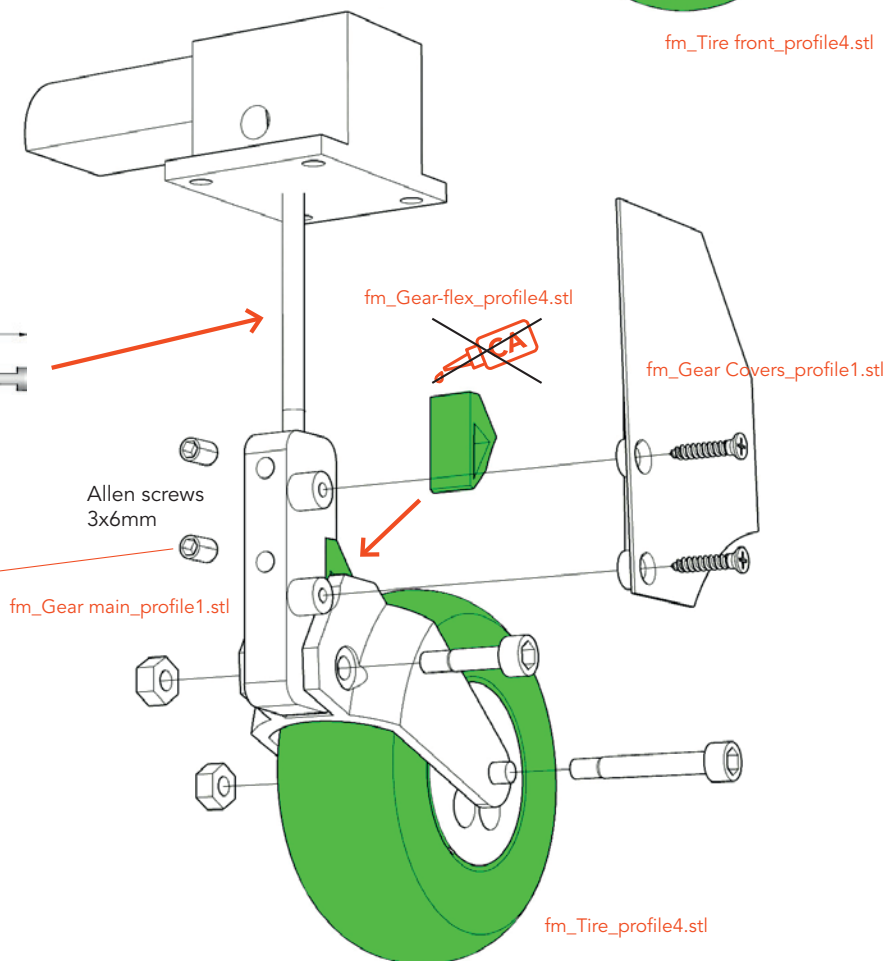

# Retract gear assembly

**TIP** If you don't have a retractable landing gear or for the waiting time of the order there is a **fixed-gear-set** in the download in the folder **Additional parts**. These parts replace the retractable landing gear. They can also be used if you want to mount larger wheels.

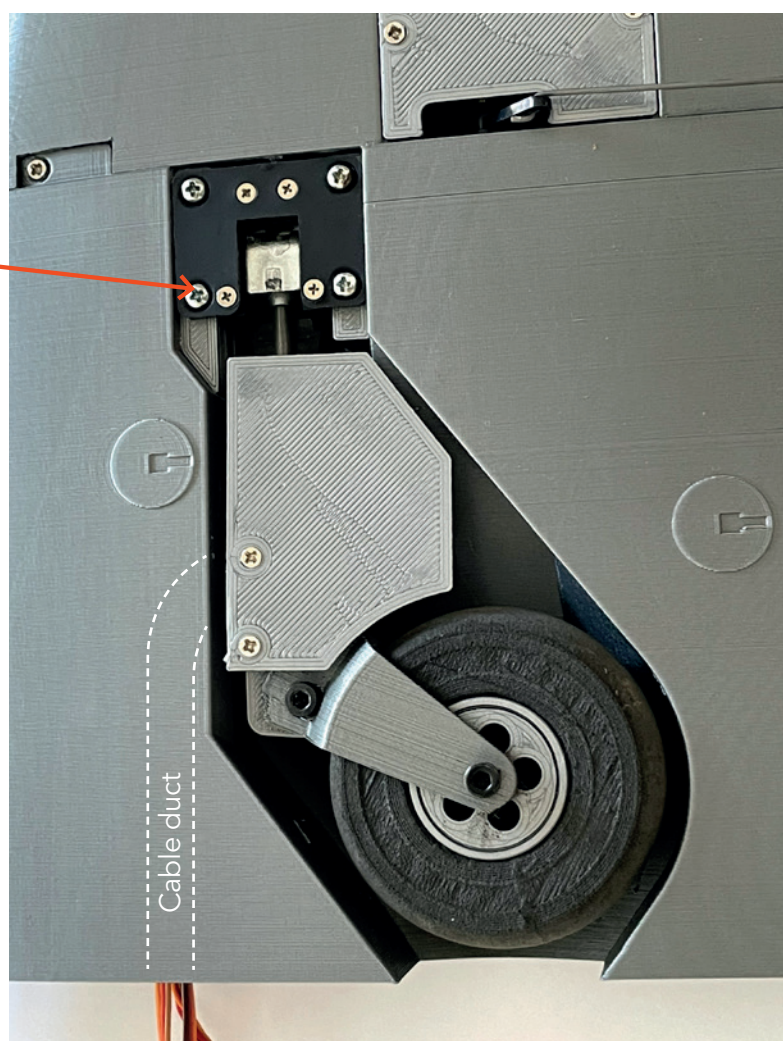
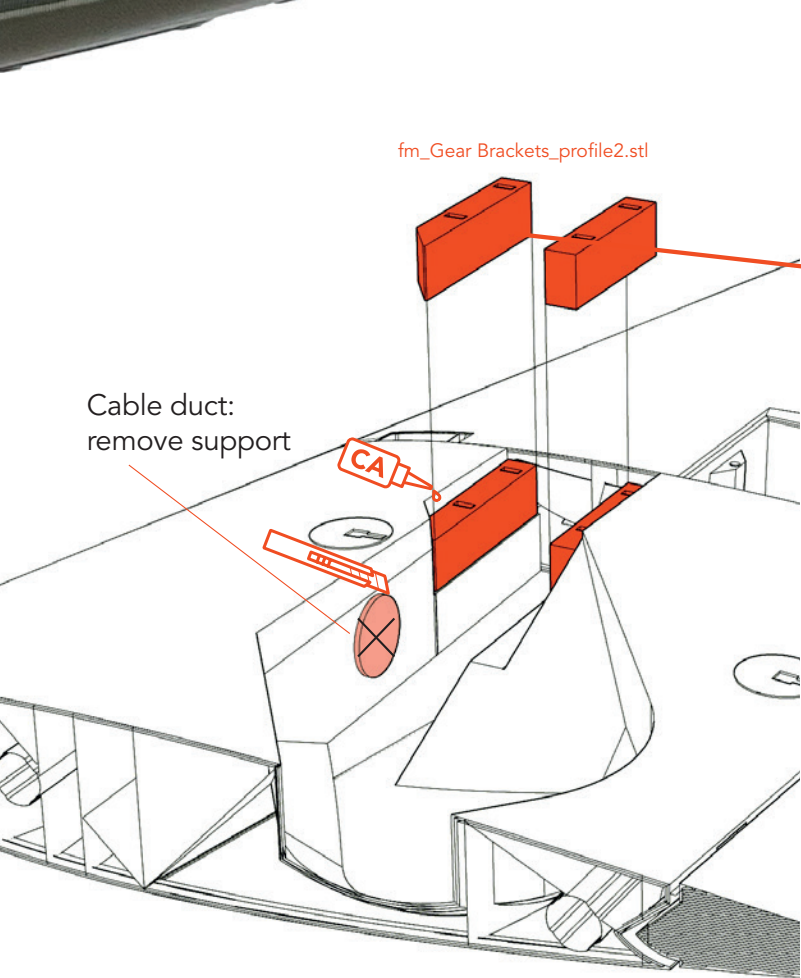
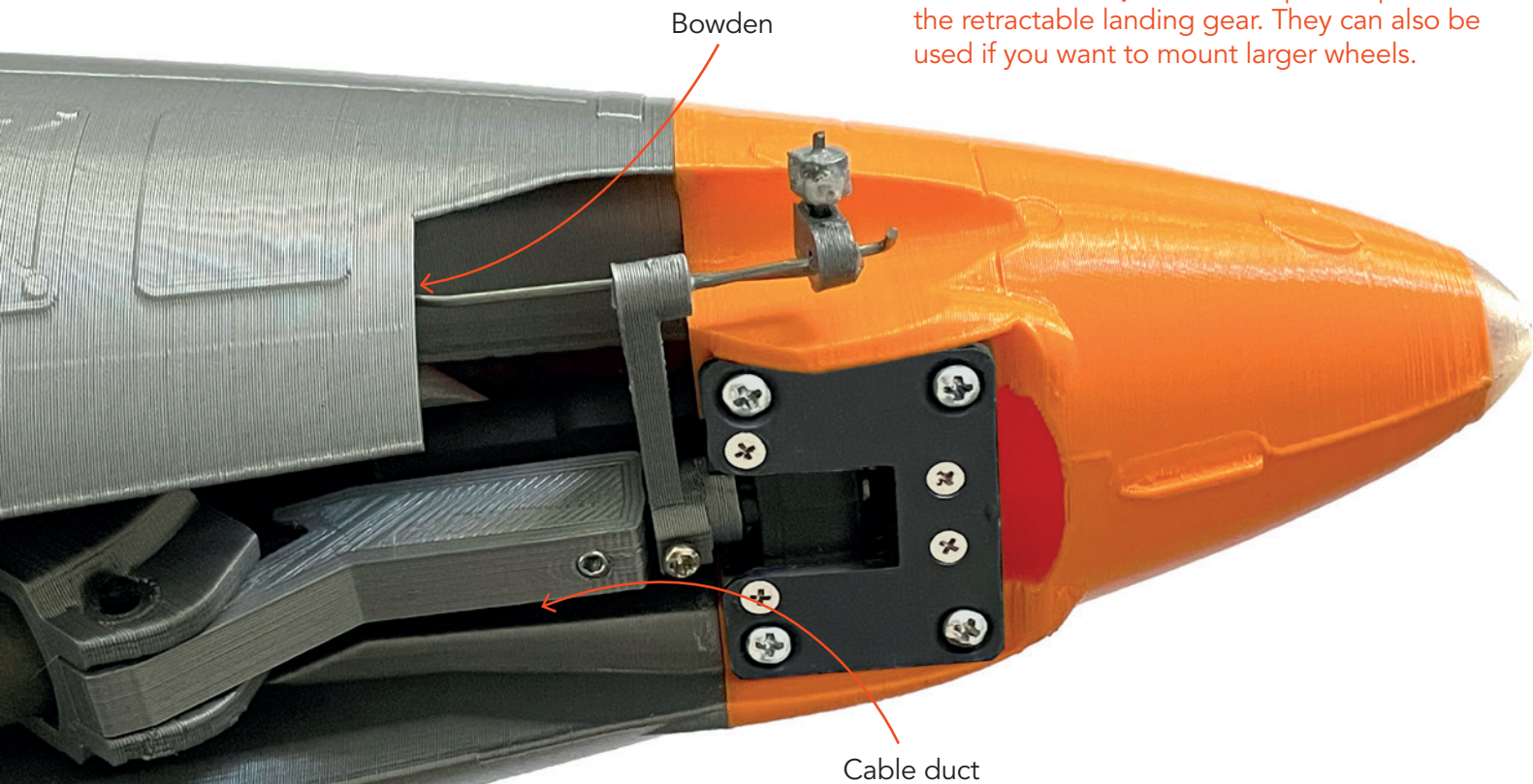

# EDF mounting

**SAFETY FIRST** Use appropriate screws for motor mounting to ensure safe operation! **Check regularly that the motor mounting is absolutely tight!**

Screw the mounting flanges to the EDF and then glue them (only with a little glue!) in the fuselage. Push the EDF backwards into the air tube beforehand and make sure that it is aligned straight. Remove the EDF again and glue the brackets well.

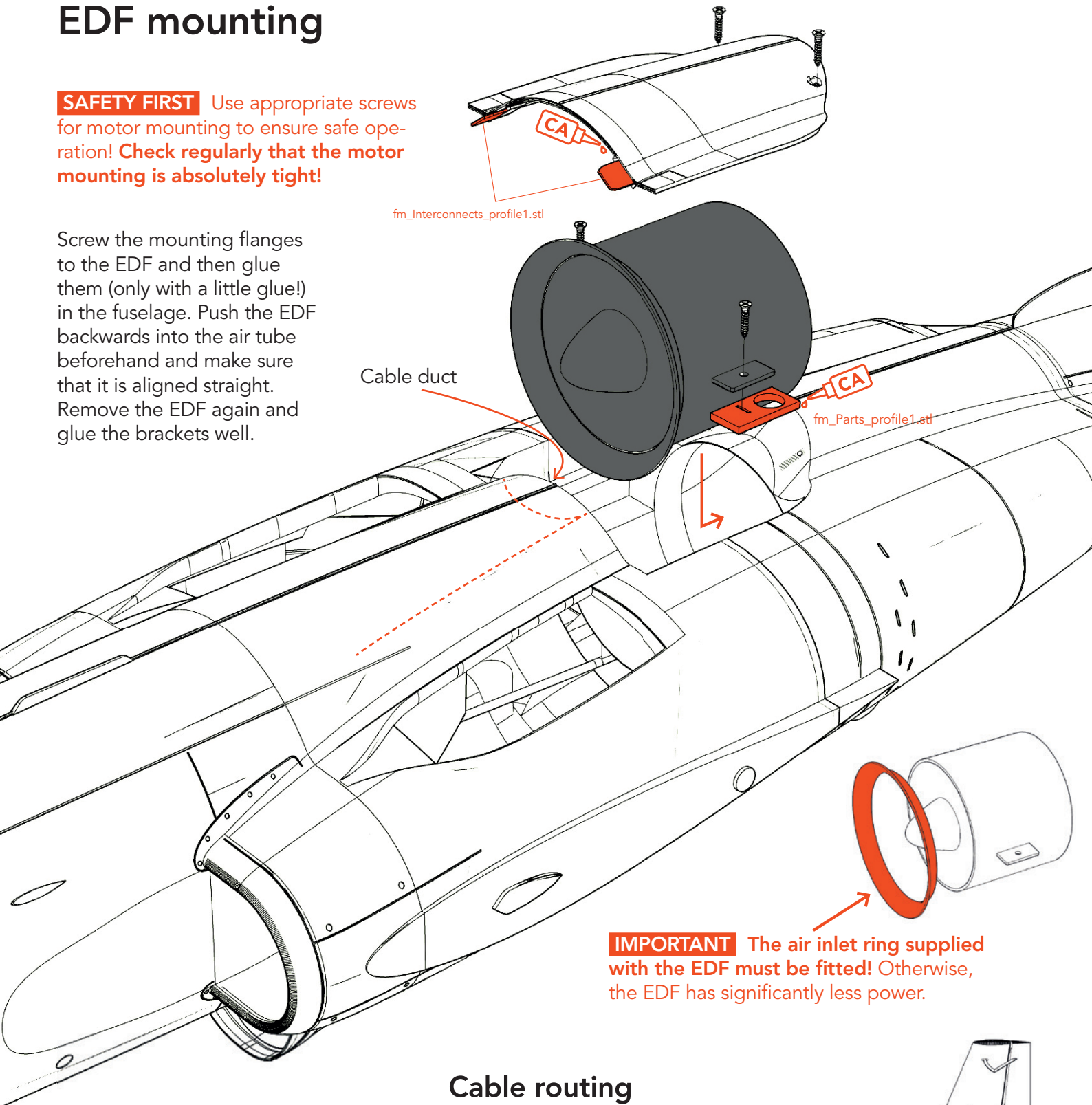

## Cable routing

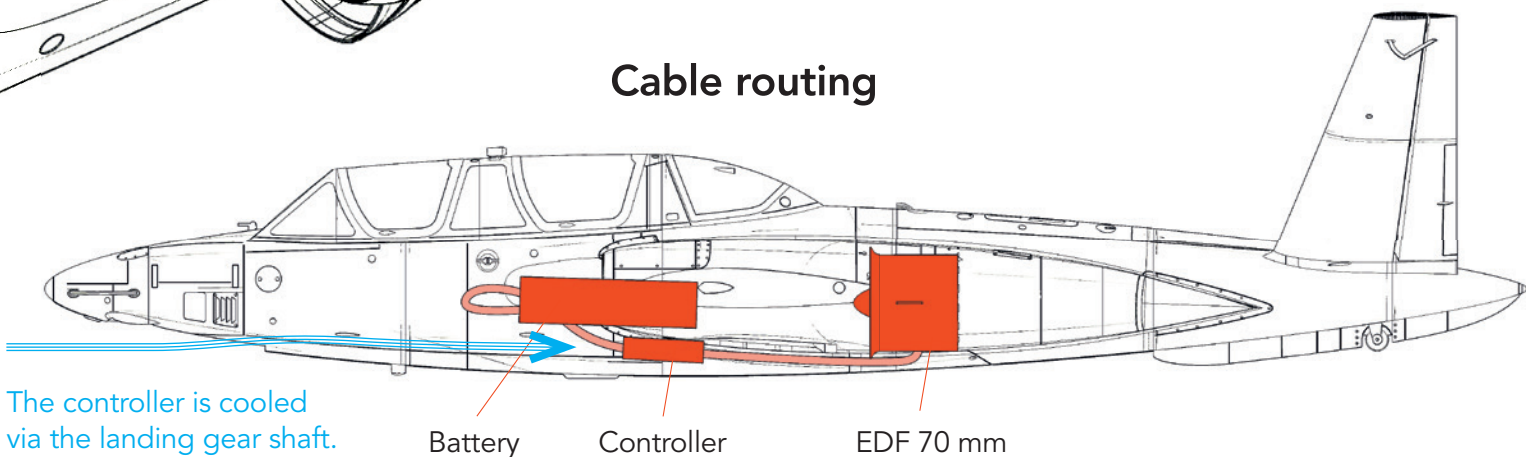

# Fuselage servo mounting

Screw the **servo brackets** from `fm_Parts_profile1.stl` to the servos and glue them in the fuselage as shown. Grind the glue joints before to achieve a perfect connection!

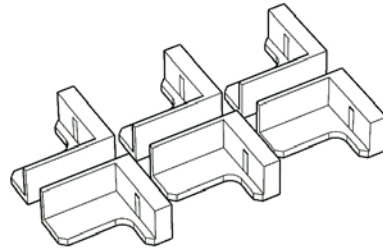

In the **Additional parts** folder you will find an **undrilled version**.

Glue the battery holder well to the fuselage.

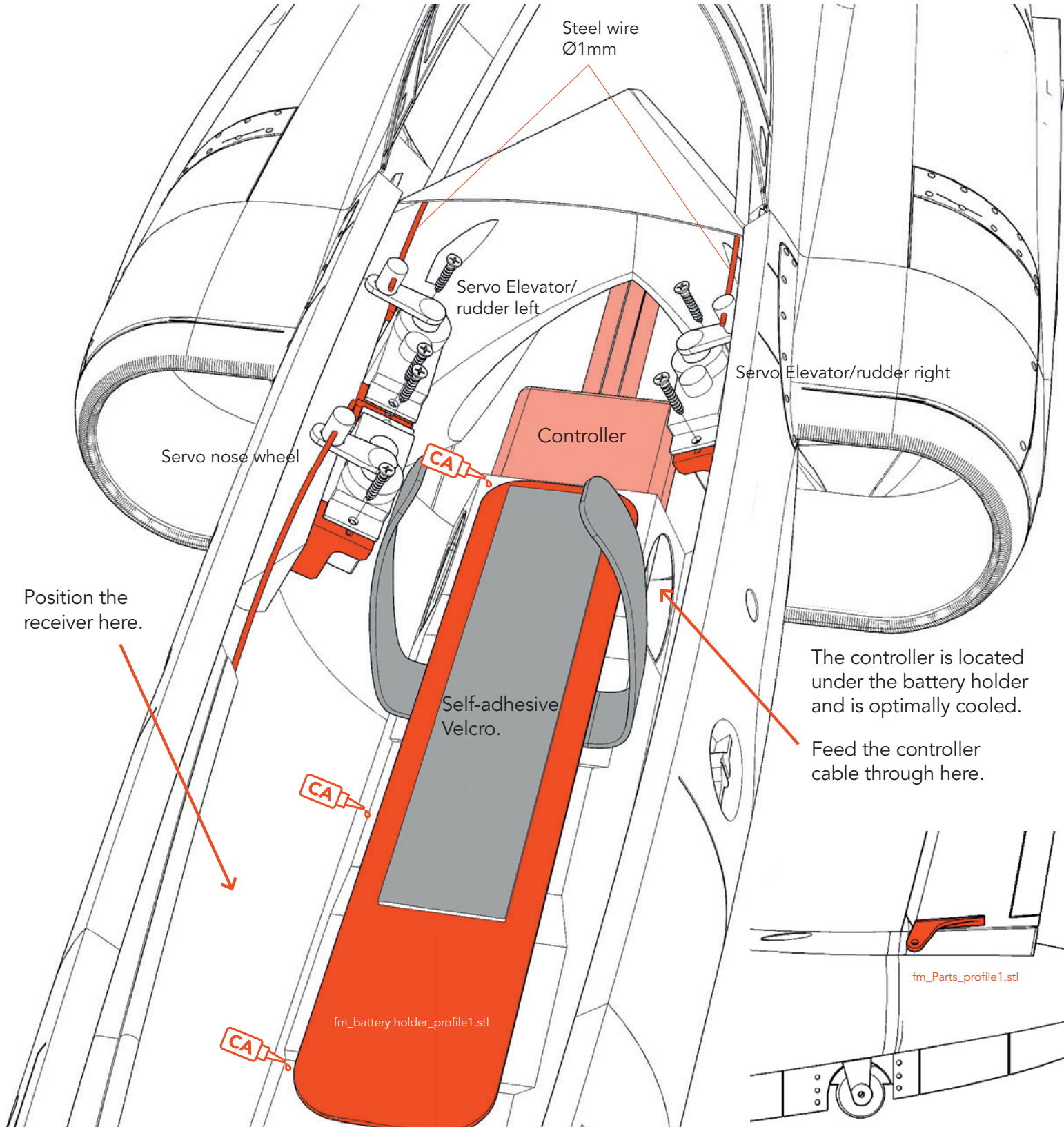

# Aileron servo mounting

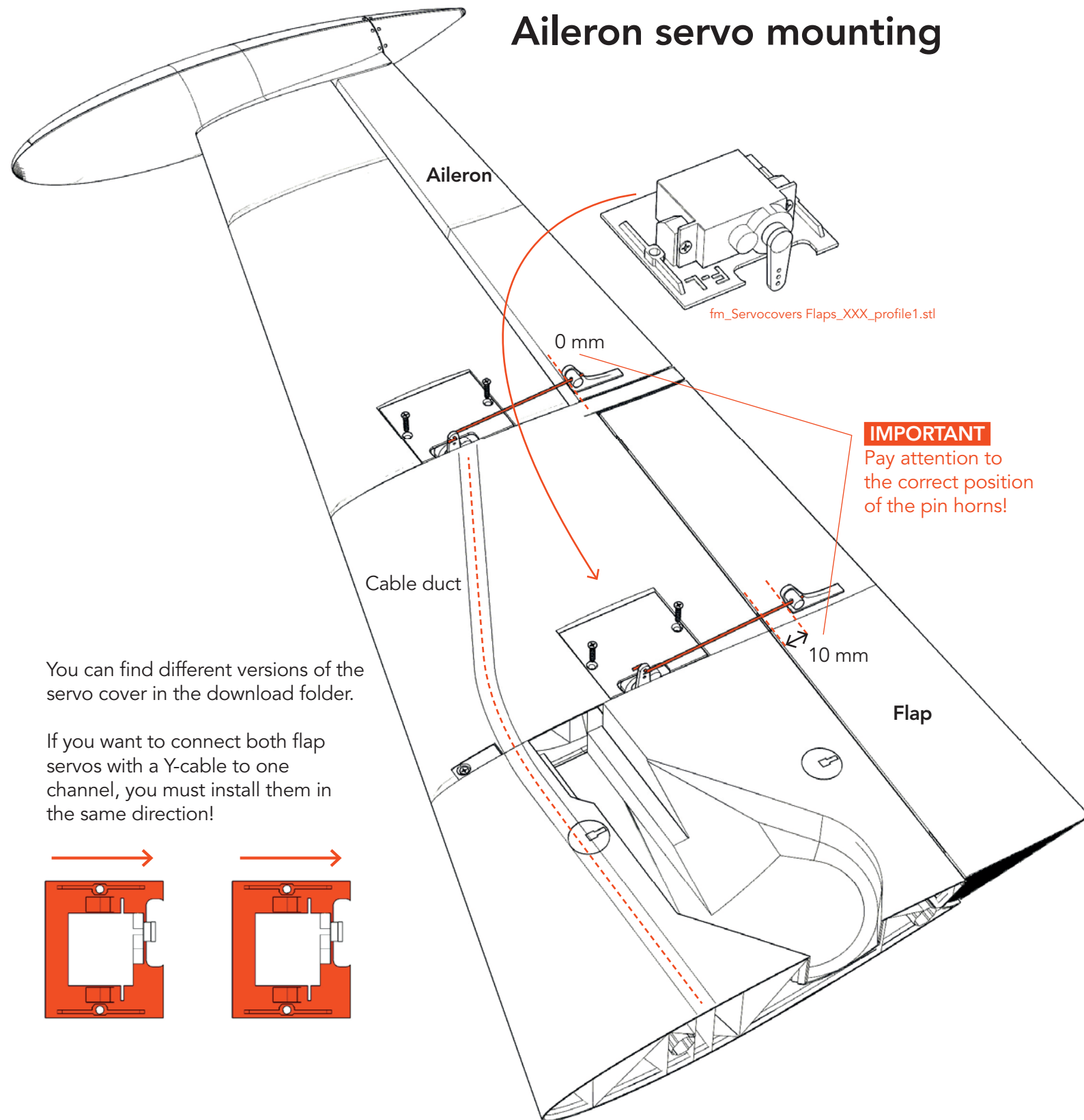

You can find different versions of the servo cover in the download folder.

If you want to connect both flap servos with a Y-cable to one channel, you must install them in the same direction!

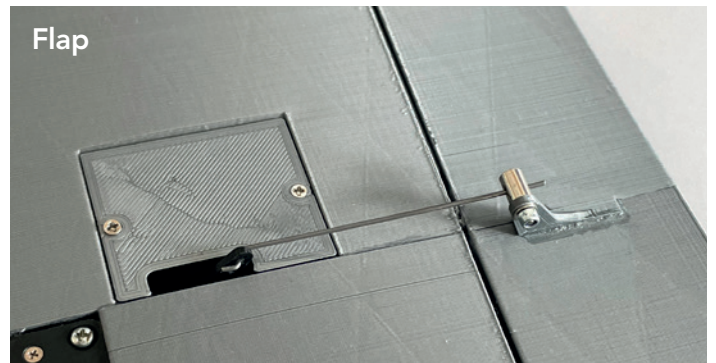
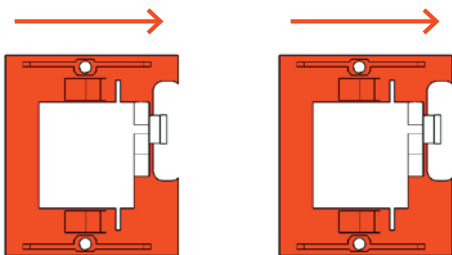

# Control Direction Test

Turn on the transmitter and connect the battery. When checking the control directions, look at the aircraft from behind.

1. Move the aileron lever to the left. The right aileron should move down and the left aileron should move up so that the aircraft tilts to the left.

## AILERON

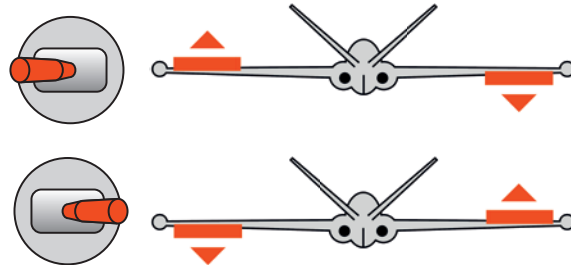

2. Move the aileron lever to the right. The right aileron should move up and the left aileron down so that the aircraft is tilting to the right.

3. Pull back the elevator lever. The elevators should move up, causing the aircraft to rise.

## ELEVATOR

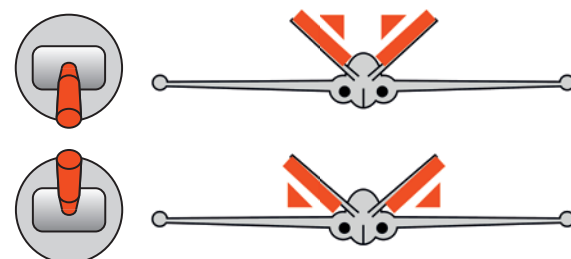

4. Push the elevator lever forward. The elevator should move down so that the aircraft sinks.

5. Move the rudder lever to the left. The rudder should move to the left.

6. Move the rudder lever to the right. The rudder should move to the right.

## RUDDER

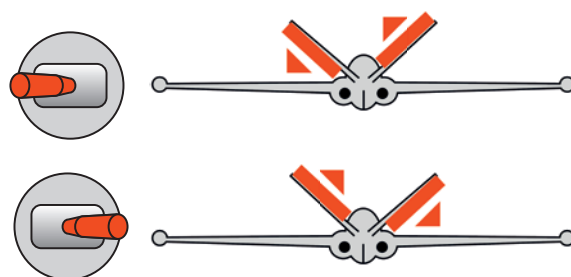

7. Move the flap switch to position 2. The flaps should move down by the set value „half“.

8. Move the flap control switch to position 3. The flaps should move down by the set value „full“.

**IMPORTANT** The flaps must be aligned exactly the same in every position, otherwise the aircraft will not fly straight!

## FLAPS

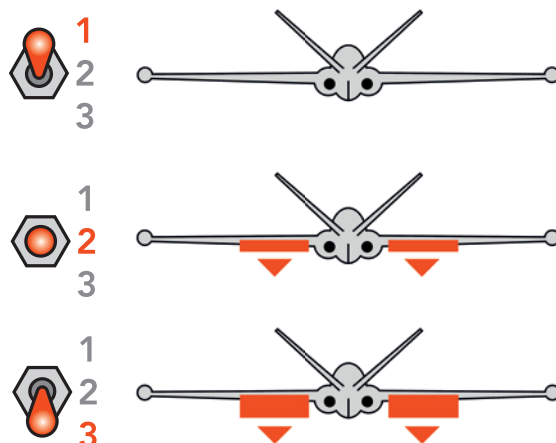

# SETTINGS FOR FLYING

After installing the electronics and setting up the transmitter, check that the control surfaces are aligned correctly. Set the transmitter trim to zero. Align all rudders to zero position. Change the position of the moving parts by changing the length of the linkage from the servo arm to the control horn. In-flight adjustments can be made later with the trim.

## Setting the servo travel

**AILERON** up: 15 mm, down: 9 mm

**RUDDER** up: 12 mm, down: 12 mm

**ELEVATOR** up: 12 mm, down: 12 mm

**FLAP** half set: 8 mm, full set: 22 mm

Please measure here!

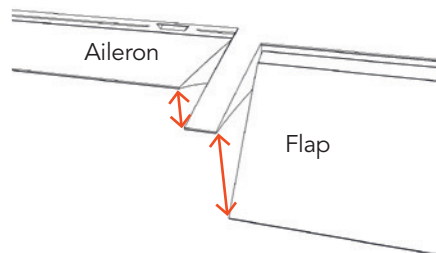

## Expo setting

**AILERON** 40 %

**ELEVATOR** 40 %

**RUDDER** 20 %

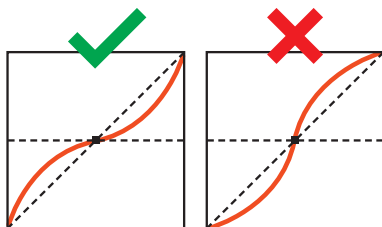

(for some remote controls a minus has to be in front of the number)

## Center of Gravity (CG)

The aircraft must balance 86 mm/3.38 inches behind the leading edge (see markings on the fuselage). For the first flight we recommend to move the center of gravity about 5 mm/0.2 inches further forward.

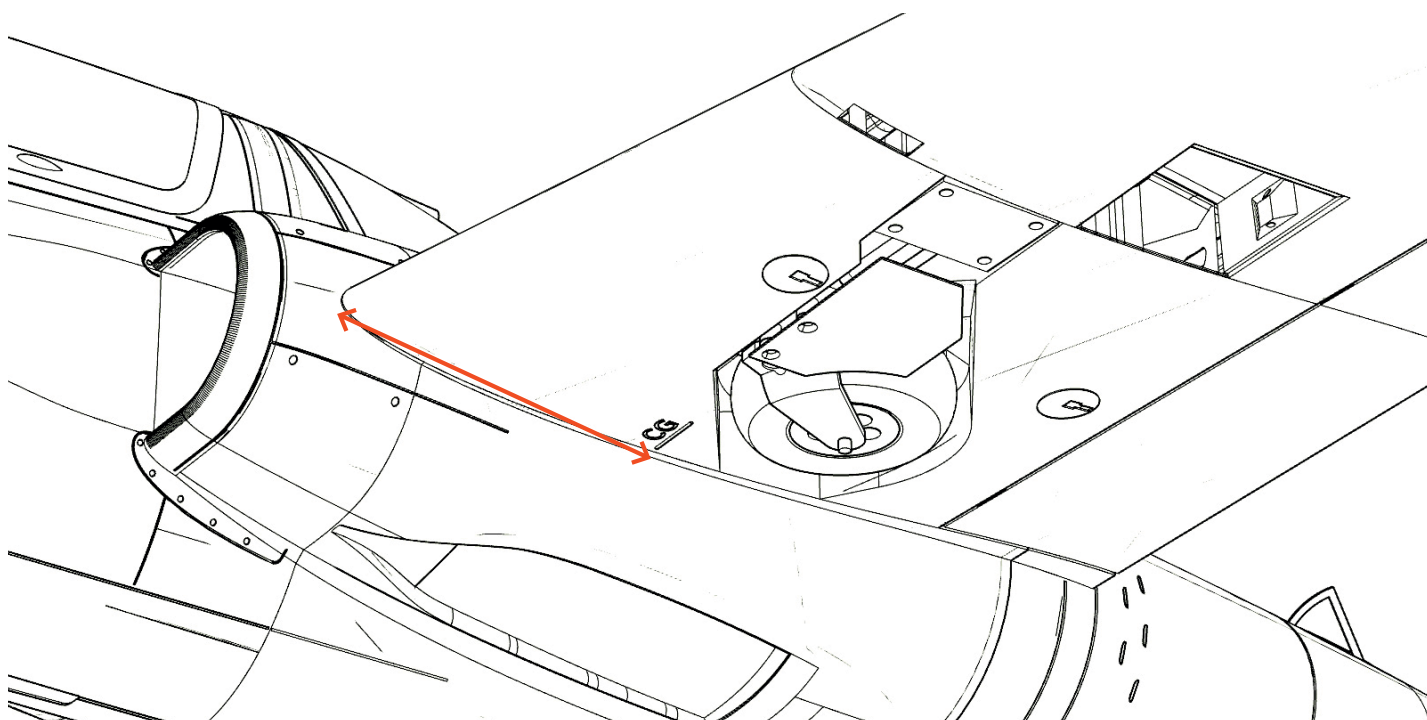

## Flight timer

Flight time will vary depending on the battery size. Expect 3 minutes under normal circumstances; however, it may be possible to fly for much longer. It is a good idea to be conservative with the flight timer until you gain experience with your airplane.

# TECHNICAL SPECIFICATIONS

**WINGSPAN** 1370 mm/53.9 inches

**LENGHT** 1134 mm/44.6 inches

**FLIGHT WEIGHT** 2030 grams (with 4S/4200 MaH-Battery)

# AGE RECOMMENDATION 14+

**NOT FOR CHILDREN UNDER 14 YEARS.  
THIS IS NOT A TOY!**

By using the download data, an RC model airplane, called „model“ for short, can be manufactured using a 3D printer. As a user of this model, only you are responsible for safe operation that does not endanger you or others, or that does not damage the model or property of others.

PLANEPRINT.com assumes no responsibility for damage to persons and property caused by pressure, transport or use of the product. Filaments, printing supplies, hardware or consumables that can not be used after faulty 3D printing will not be replaced by PLANEPRINT.com in any way.

When operating, always keep a safe distance from your model in all directions to avoid collisions and injuries.

This model is controlled by a radio signal. Radio signals can be disturbed from outside without being able to influence it. Interference can lead to a temporary loss of control.

Always operate your model on open terrains, far from cars, traffic and people.

Always follow the instructions and warnings for this product and any optional accessories (servos, receivers, motors, propellers, chargers, rechargeable batteries, etc.) carefully.

Keep all chemicals, small parts and electrical components out of the reach of children.

Avoid water contact with all components that are not specially designed and protected. Moisture damages the electronics.

Never take an item of the model or accessory in your mouth as this can lead to severe injuries or even death.

Never operate your model with low batteries in the transmitter or model.

Always keep the model in view and under control. Use only fully charged batteries.

Always keep the transmitter switched on when the model is switched on.

Always remove the battery before disassembling the model.

Keep moving parts clean and dry at all times.

Always allow the parts to cool before touching them.

Always remove the battery after use.

Make sure that the Failsafe is properly set before the flight.

Never operate the model with damaged wiring.

Never touch moving parts.

We develop our models to the best of our knowledge and belief. We accept no liability for consequential damage and injuries caused by improper use. **Please be careful when handling motors, batteries and propellers** and only move your model with insurance and in approved places!

**PLANE  
PRINT.com**

*very light 3d printable rc planes*