

# PLANE PRINT

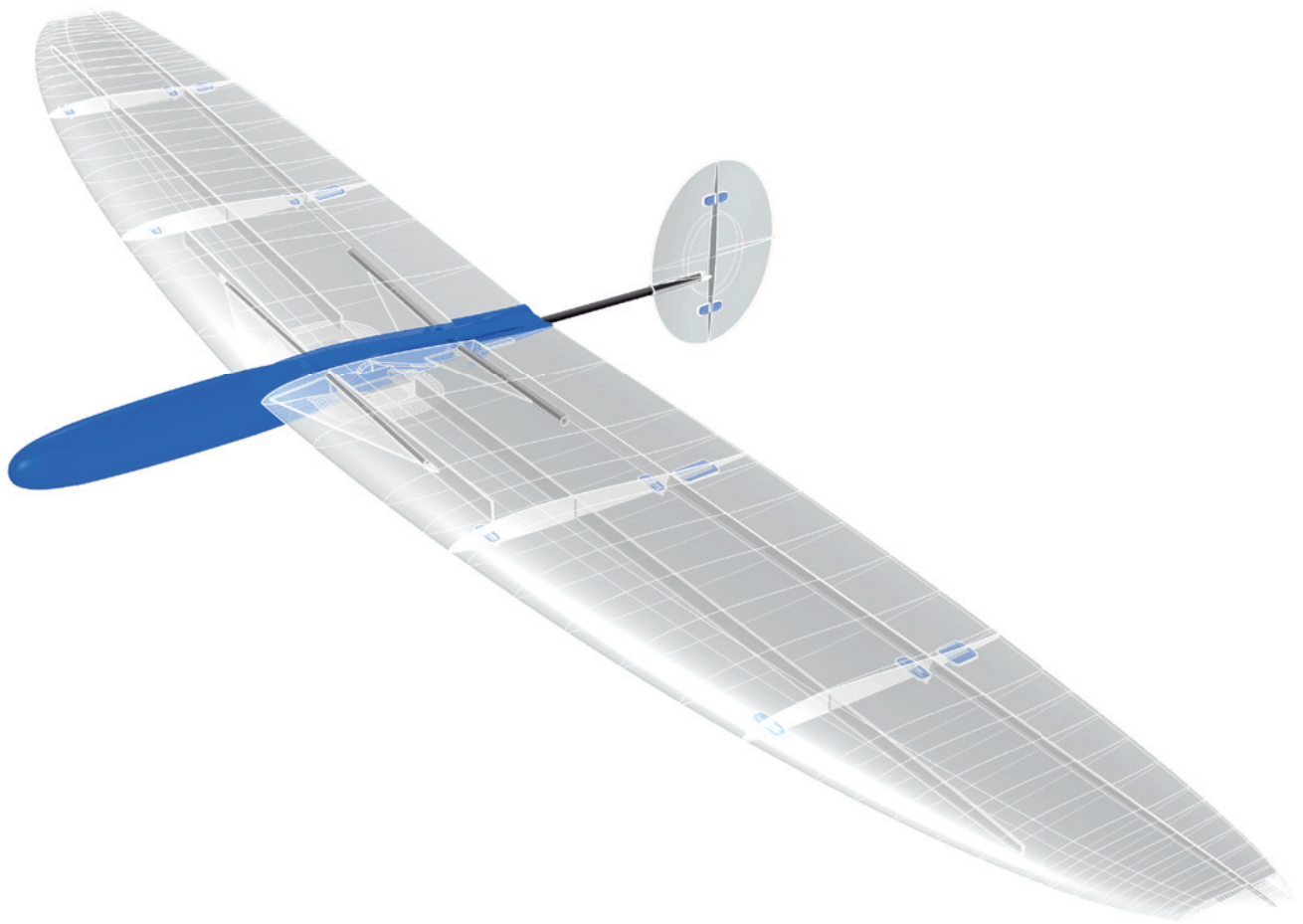

## PLANE PRINT *Halo*

Flying wing for slope and coast flying



[www.planeprint.com](http://www.planeprint.com)

the **ONLY** place where you can get  
original Planeprint STL files **legally!**

# PLANE PRINT *Halo*

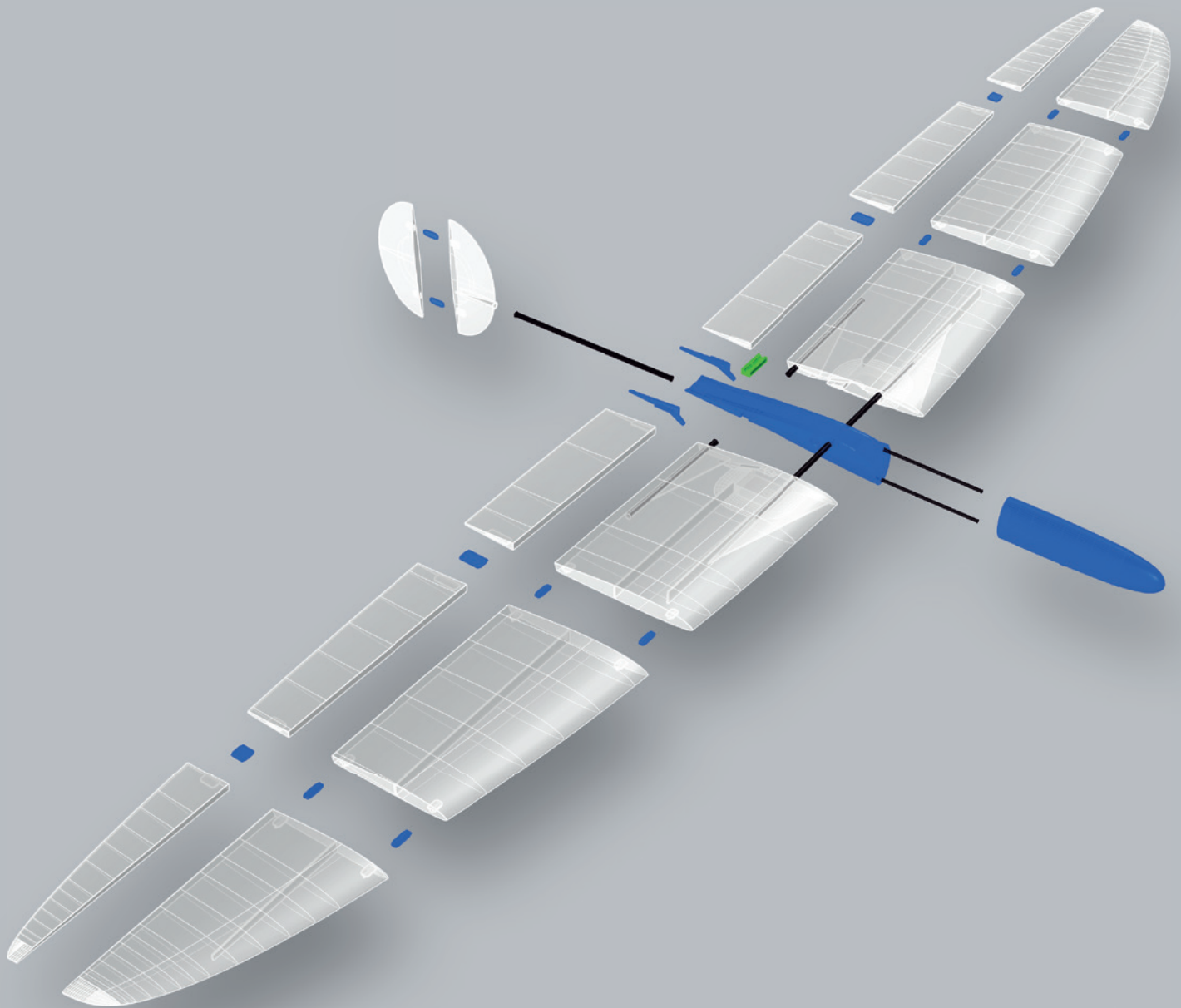

# RC Components

**RECEIVER** 2 Channel

**BATTERY** If you use high voltage servos you can use a small 2S/350 mAh Lipo battery, otherwise a receiver battery (size maximum 50x27x17mm)

**SERVOS** 2 Nano Servos (8 mm thick, maximum 9 mm) for example:

- CHASERVO D S 06 high voltage (fits perfectly)
- Hitec HS 40 Eco Servo 4,8g

## Required accessoires – basic equipment

- LW-PLA (cannot be replaced by PLA or pre-foamed LW), ~190 grams
- PLA or Tough PLA, ~50 grams
- TPU A95, ~10 grams (Can be replaced by LW-PLA)
  
- some tapping screws Ø2mm
- CA super glue (liquid and medium)
- CA activator
- Carbon **tube** Ø5\*1000mm, 1 piece
- Carbon **rod** Ø3\*1000mm, 1 piece
- Steel wire Ø0.8\*100mm (Ø1 also possible), 2 pieces
- UHU POR glue (or another handicraft glue)
- Fabric tape for the aileron hinges
- some lead

## Tools

- Cutter knife
- Drill Ø1.5mm
- small Phillips screwdriver
- Metal saw
- Side cutter
- Needle nose pliers



Tapping screws Ø2mm

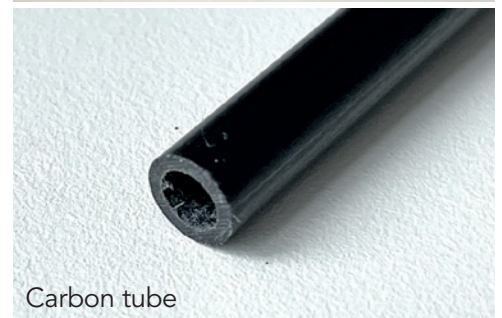

Carbon tube

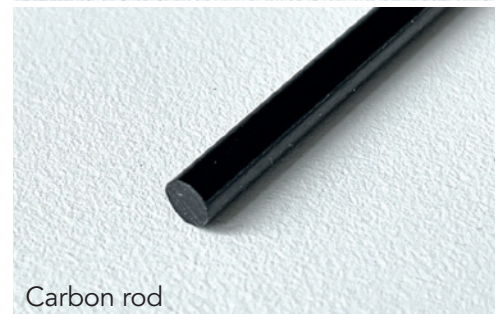

Carbon rod



The development of a complex, airworthy RC flight model to express on any standard 3D printer is a very extensive process. **Therefore, we appeal to your fairness not to forward the STL data you have acquired to third parties.**

Thank you for your understanding and have fun with your PLANEPRINT MODEL!

---

## Printing the parts – Printing profiles

This manual is constantly being improved and supplemented, we recommend downloading the **latest version** from our website **before building**.

To print all **PLANEPRINT** models **you need to set some basic profiles in Cura** (If you use another slicer, please set the same parameters).

You can find the description at [www.planepprint.com/print](http://www.planepprint.com/print)

For this model you need the following profiles:



# PROFILE P1\_Fullbody Tough PLA or PLA



The information about the basic settings you can find on our website at PRINT.  
Please note the additional settings for the individual parts!

## P1\_Fuselage\_halo.stl

**MATERIAL** PLA, Weight: ~ 18 g (without support)

### ADDITIONAL SETTINGS

- Wall Line Count/Perimeters: 1
- Infill Density/Fill Density: 6 %
- Infill Pattern/Fill Pattern: Gyroid
- set Support

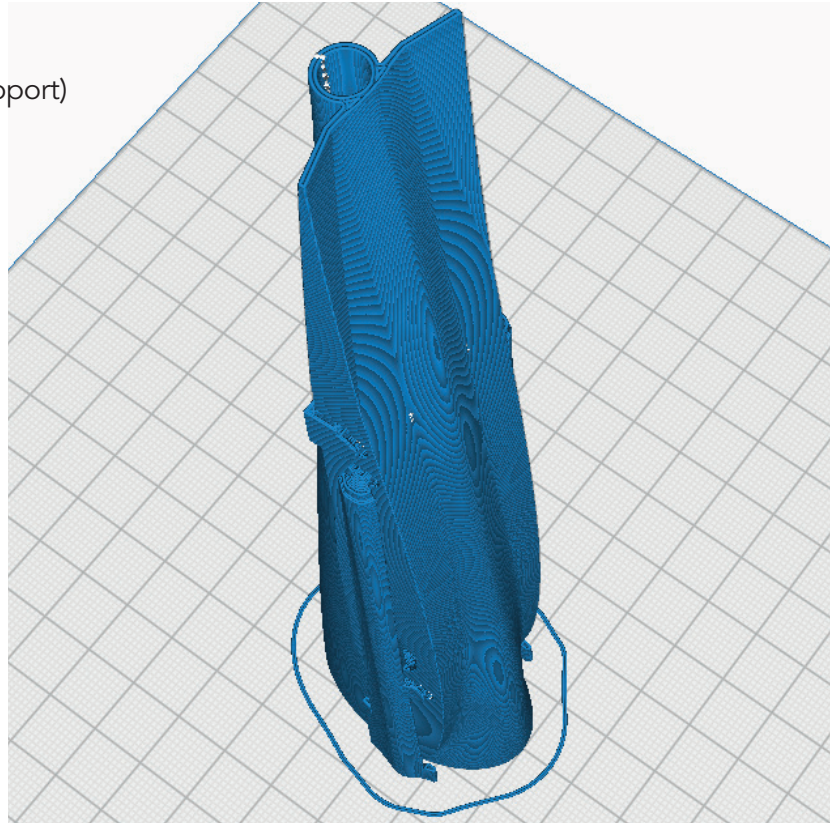

## P1\_Nose\_halo.stl

**MATERIAL** PLA, Weight: ~ 19 g

### ADDITIONAL SETTINGS

None required

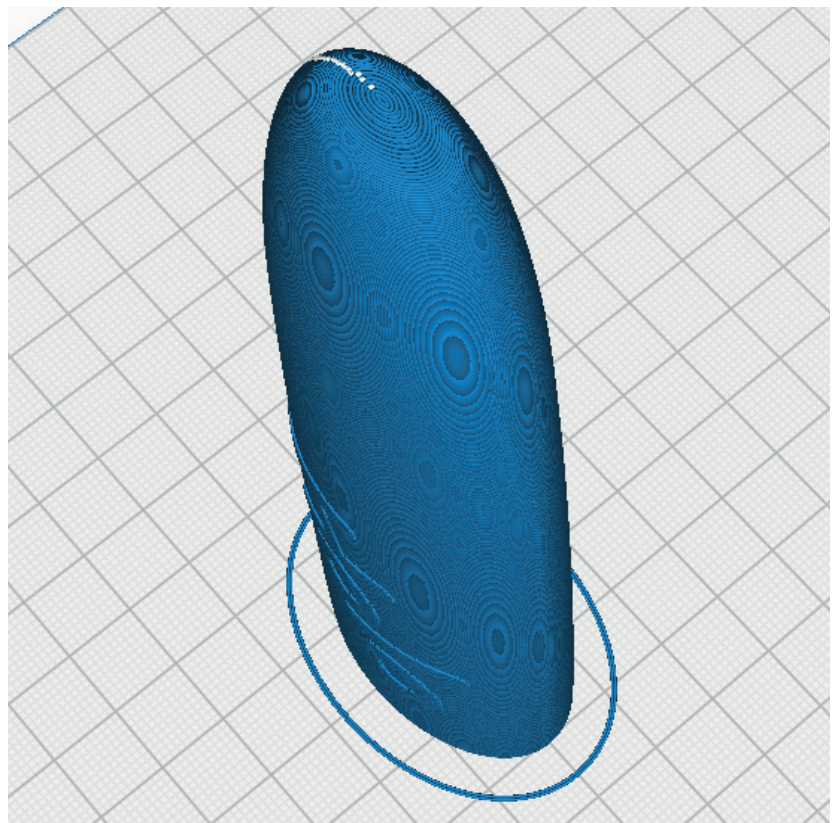

# PROFILE P1\_Fullbody **Tough PLA or PLA**



The information about the basic settings you can find on our website at PRINT.  
**Please note the additional settings for the individual parts!**

## P1\_Parts\_halo.stl

**MATERIAL** PLA, Weight: ~ 4 g

### **ADDITIONAL SETTINGS**

None required

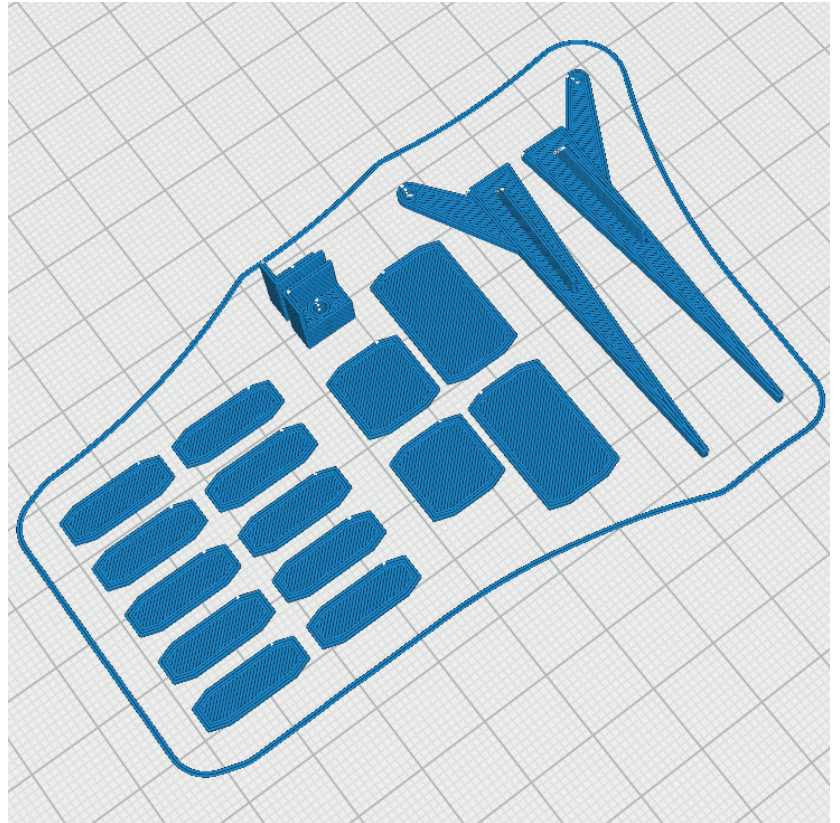

# PROFILE P4\_Flex TPU A95



The information about the basic settings you can find on our website at PRINT.  
Please note the additional settings for the individual parts!

## P4\_Wing mount\_halo.stl

**MATERIAL** TPU A95, Weight: ~ 1 g

### **ADDITIONAL SETTINGS**

- Infill Density: 100 %

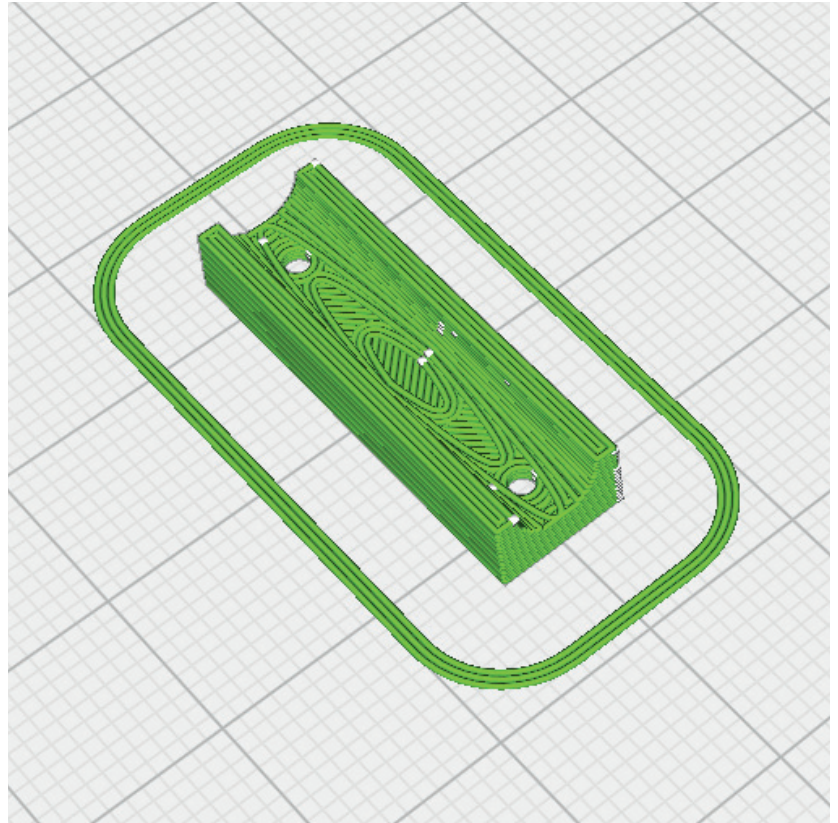

# PROFILE P5\_Gyroid Light-Weight LW-PLA!



The information about the basic settings you can find on our website at PRINT.

**Please note the additional settings for the individual parts!**

**It is essential to print these parts with LW-PLA!**

**Basic settings for LW-PLA:** Please follow the instructions in our **WINGTEST AND CALIBRATION TOOL** on our website for correct adjustment! **For optimum quality, there should only ever be one part on the build plate!**

**P5\_Aileron L 1\_halo.stl** and  
**P5\_Aileron R 1\_halo.stl**

**MATERIAL** LW PLA, Weight: ~ 7 g

### **ADDITIONAL SETTINGS**

- Infill Density/Fill Density: 4 %

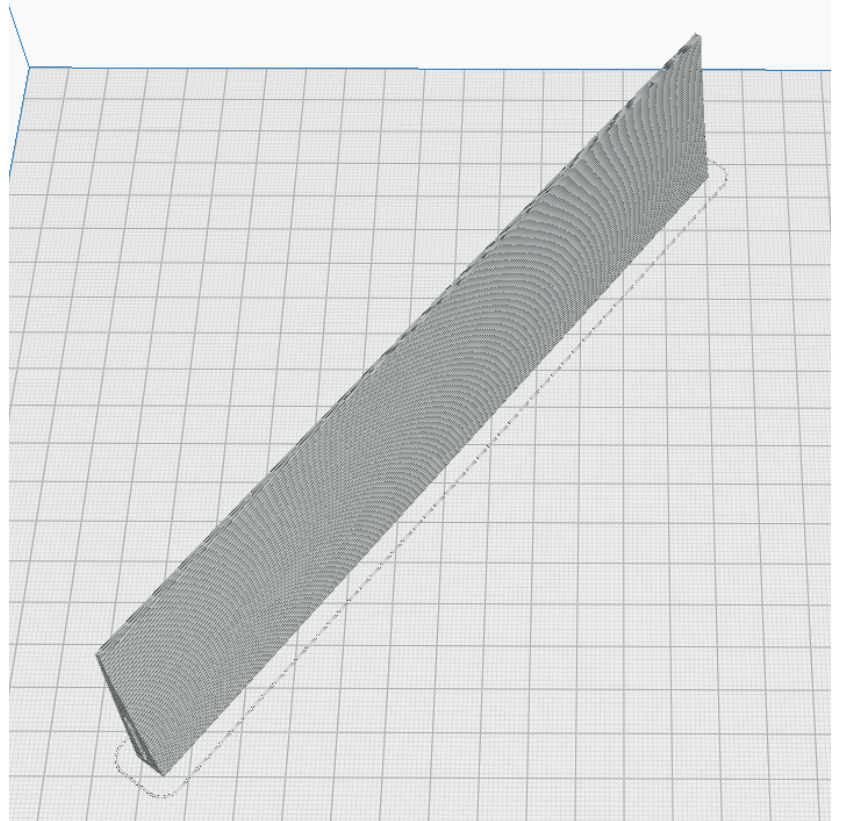

**P5\_Aileron L 2\_halo.stl** and  
**P5\_Aileron R 2\_halo.stl**

**MATERIAL** LW PLA, Weight: ~ 7 g

### **ADDITIONAL SETTINGS**

- Infill Density/Fill Density: 4 %

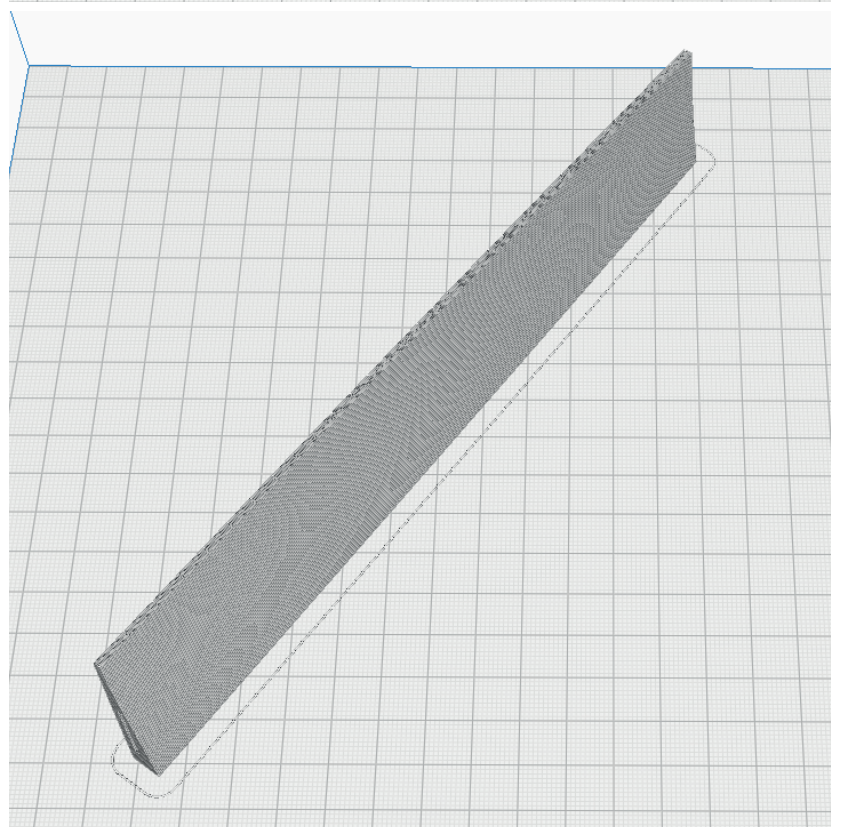

# PROFILE P5\_Gyroid Light-Weight LW-PLA!



The information about the basic settings you can find on our website at PRINT.

**Please note the additional settings for the individual parts!**

**It is essential to print these parts with LW-PLA!**

**Basic settings for LW-PLA:** Please follow the instructions in our **WINGTEST AND CALIBRATION TOOL** on our website for correct adjustment! **For optimum quality, there should only ever be one part on the build plate!**

P5\_Aileron L 3\_halo.stl and  
P5\_Aileron R 3\_halo.stl

**MATERIAL** LW PLA, Weight: ~ 4 g

## **ADDITIONAL SETTINGS**

- Infill Density/Fill Density: 4 %

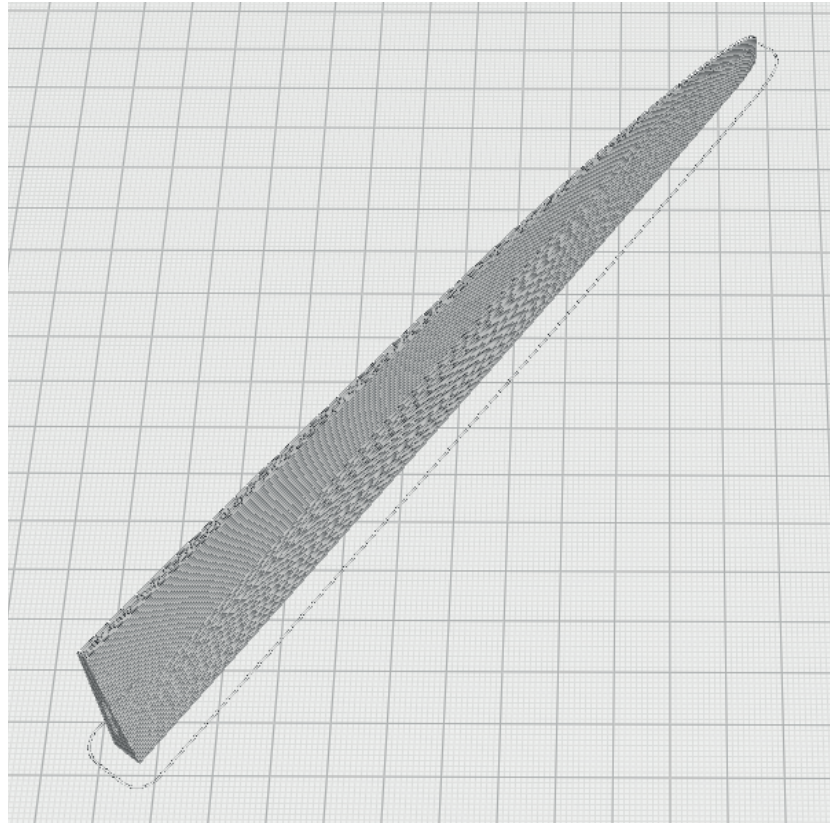

P5\_Rudder 1\_halo.stl

**MATERIAL** LW PLA, Weight: ~ 4 g

## **ADDITIONAL SETTINGS**

- Infill Density/Fill Density: 4 %
- set Brim

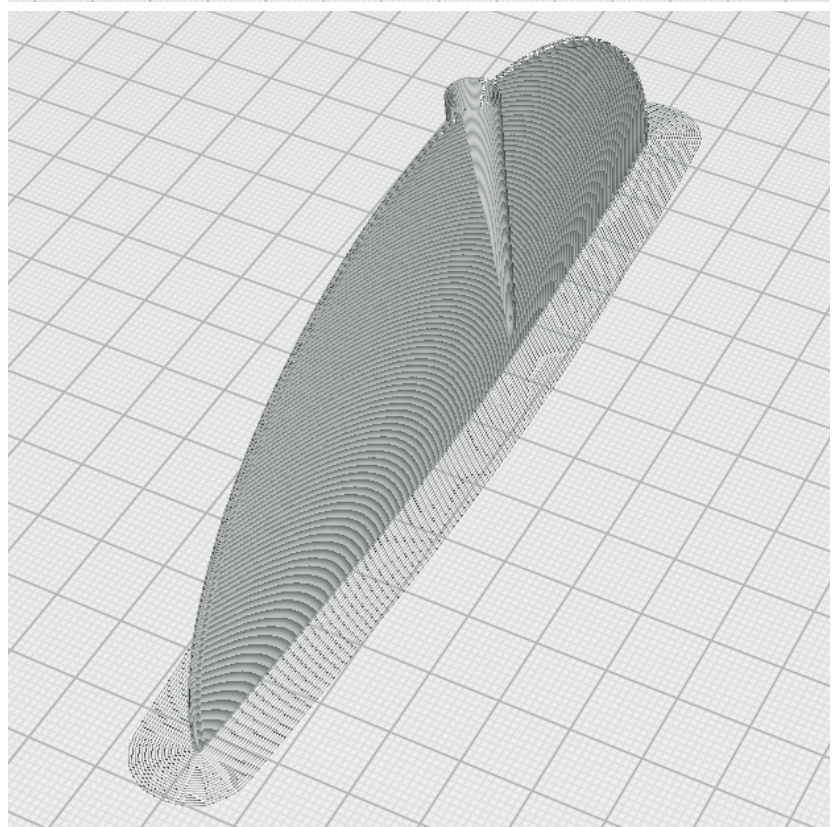

# PROFILE P5\_Gyroid Light-Weight LW-PLA!



The information about the basic settings you can find on our website at PRINT.

**Please note the additional settings for the individual parts!**

**It is essential to print these parts with LW-PLA!**

**Basic settings for LW-PLA:** Please follow the instructions in our **WINGTEST AND CALIBRATION TOOL** on our website for correct adjustment! **For optimum quality, there should only ever be one part on the build plate!**

## P5\_Rudder 2\_halo.stl

**MATERIAL** LW PLA, Weight: ~ 4 g

### ADDITIONAL SETTINGS

- Infill Density/Fill Density: 4 %
- set Brim

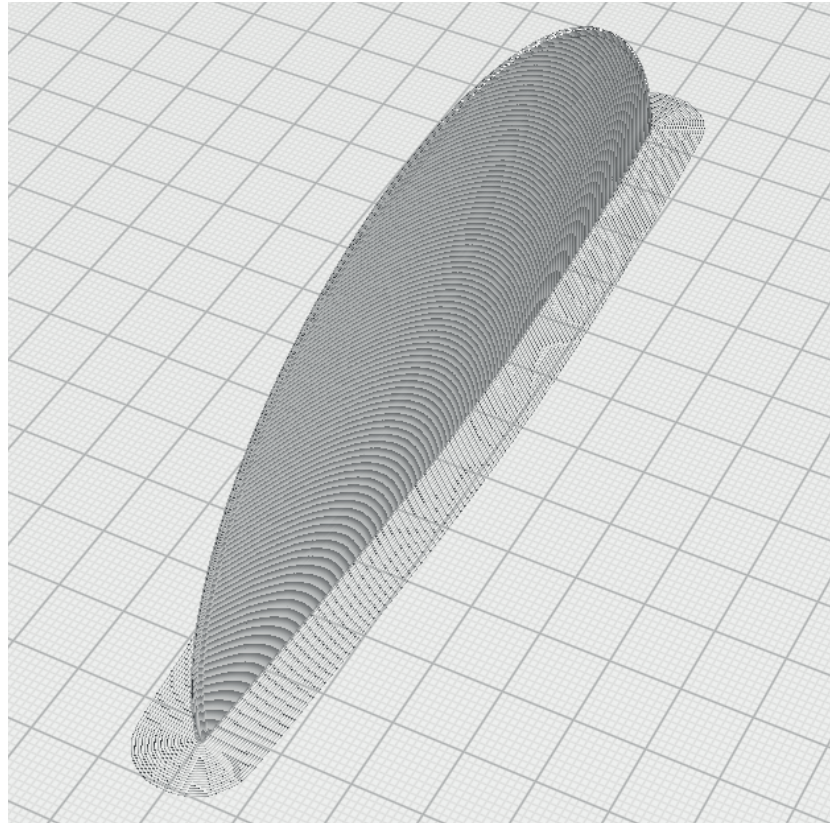

## P5\_Wing L 1\_halo.stl and P5\_Wing R 1\_halo.stl

**MATERIAL** LW PLA, Weight: ~ 33 g

### ADDITIONAL SETTINGS

- Infill Density/Fill Density: 4 %

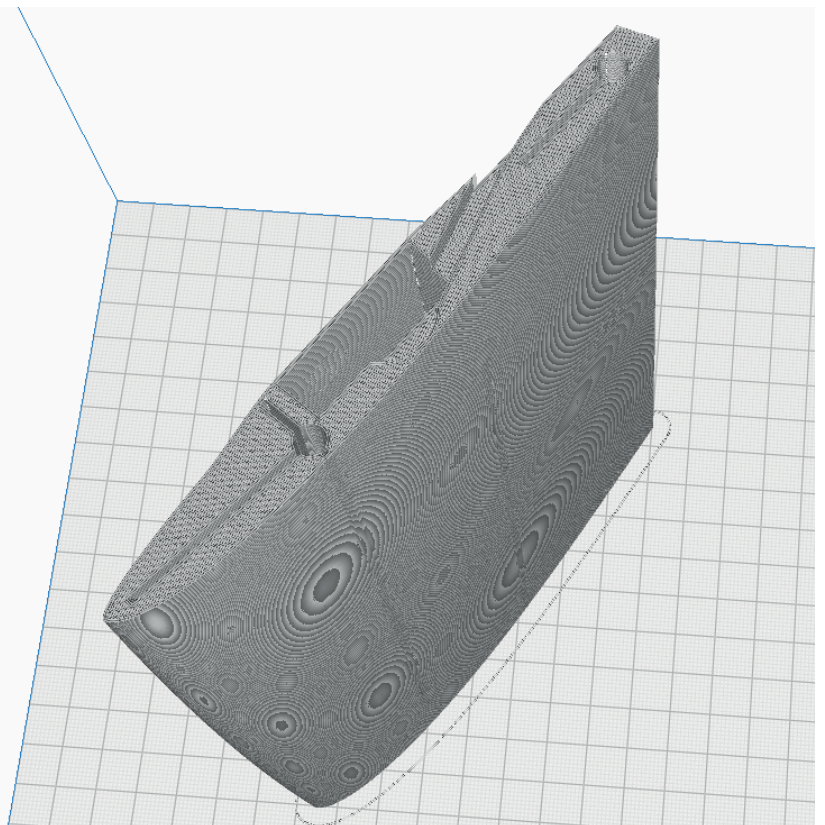

# PROFILE P5\_Gyroid Light-Weight LW-PLA!



The information about the basic settings you can find on our website at PRINT.

**Please note the additional settings for the individual parts!**

**It is essential to print these parts with LW-PLA!**

**Basic settings for LW-PLA:** Please follow the instructions in our **WINGTEST AND CALIBRATION TOOL** on our website for correct adjustment! **For optimum quality, there should only ever be one part on the build plate!**

P5\_Wing L 2\_halo.stl and  
P5\_Wing R 2\_halo.stl

**MATERIAL** LW PLA, Weight: ~ 24 g

## **ADDITIONAL SETTINGS**

- Infill Density/Fill Density: 4 %

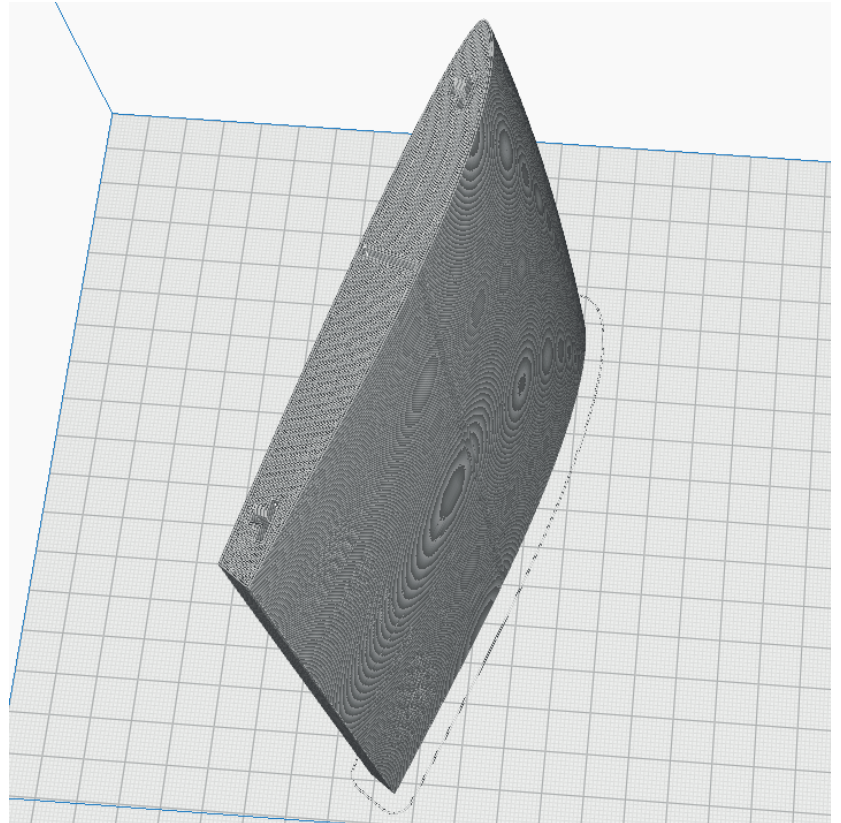

P5\_Wing L 3\_halo.stl and  
P5\_Wing R 3\_halo.stl

**MATERIAL** LW PLA, Weight: ~ 13 g

## **ADDITIONAL SETTINGS**

- Infill Density/Fill Density: 4 %
- set Brim

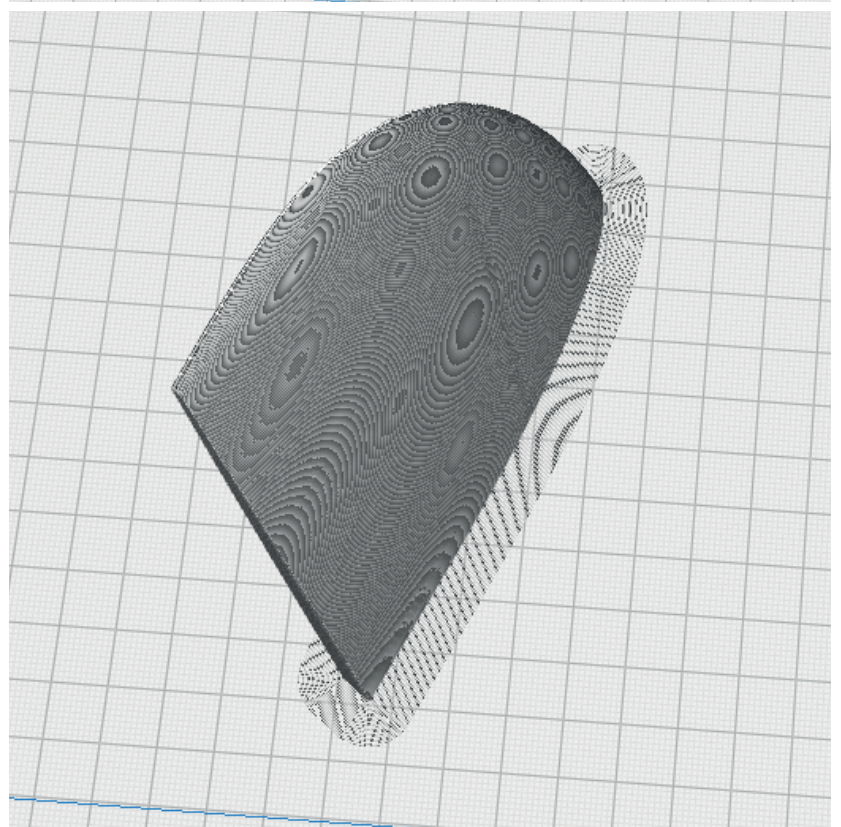

# Fuselage assembly

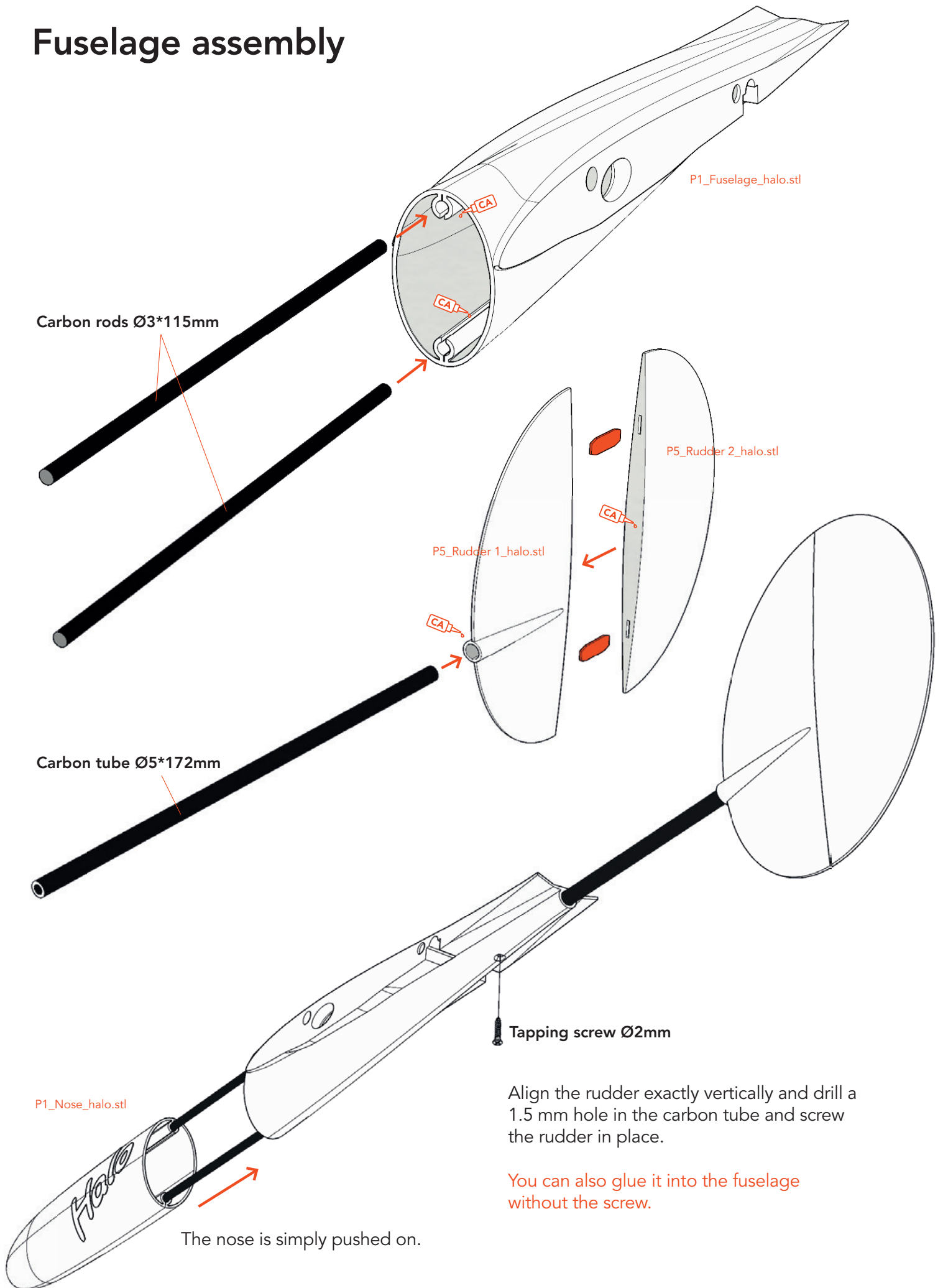

# Wing assembly

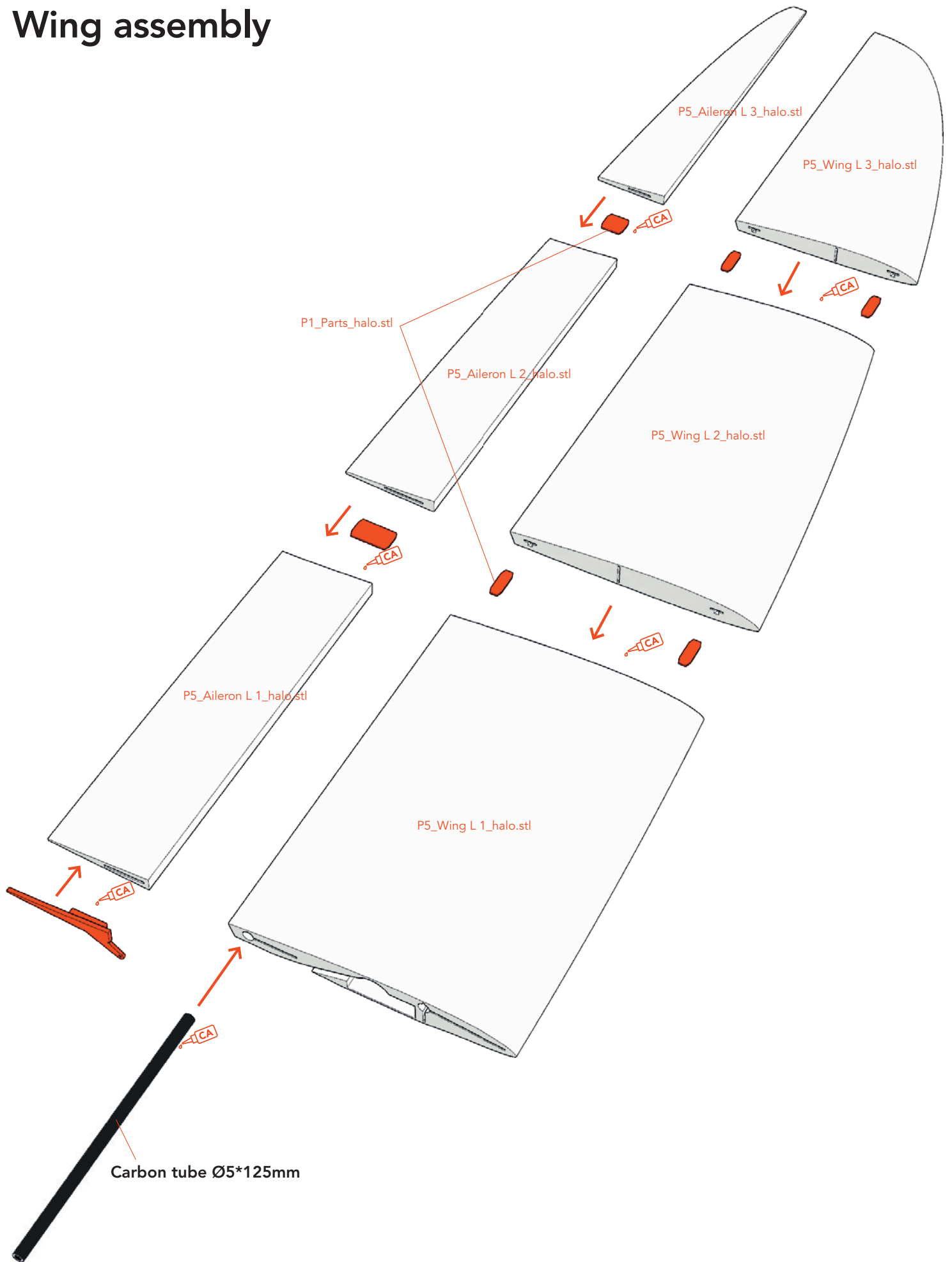

# Aileron assembly

The hinges are simply made with **adhesive tape**. To ensure that the tape holds well, you should coat the gluing area (LW PLA) with UHU (or UHU POR) beforehand. Once the adhesive has dried, stick the tape first to the wing and then to the aileron. **Leave a small gap so that the ailerons can be moved easily.**

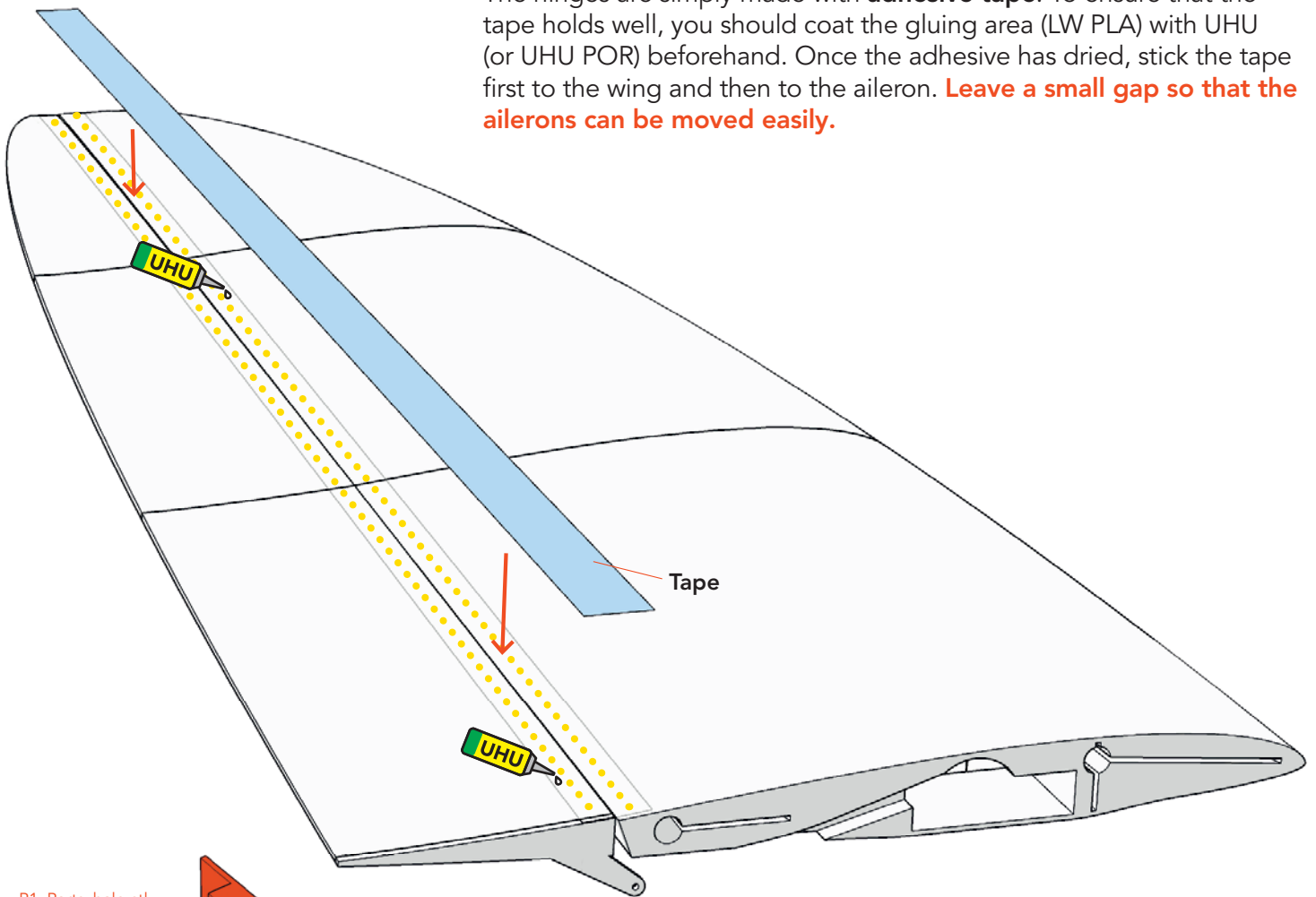

P1\_Parts\_halo.stl

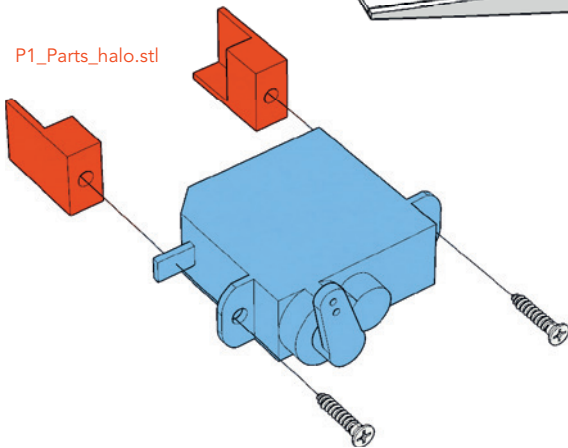

Screw the servo brackets to the servo and position the servo in the wing as shown here. The servo arm must be at 90° to the wire at zero position. When the position is correct, carefully let some CA glue run to the servo brackets without touching the servo or the wire. Then carefully unscrew the servo and glue the brackets firmly in place.

**The servo must not protrude over the wing!**



Steel wire  $\text{Ø}0.8 \times 66.4\text{mm}$

The servo must be as close as possible to the underside of the wing.

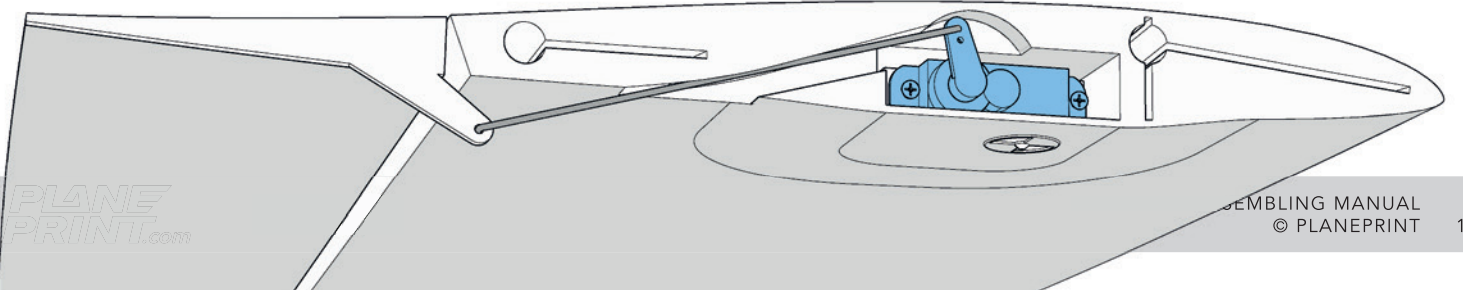
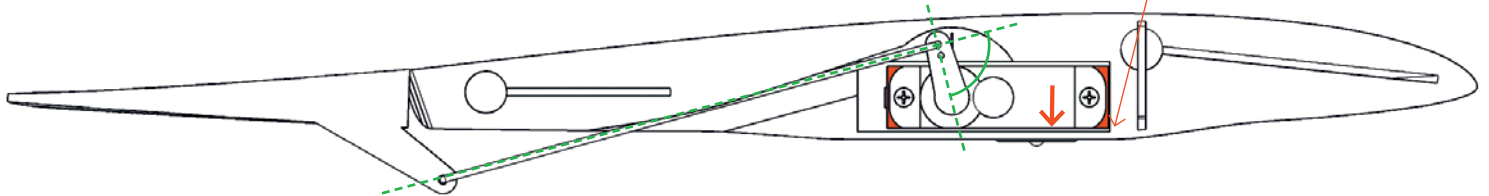

# Wing fastening

Insert the TPU mount into the fuselage and the wings too. Then drill the two 1.5 mm holes in the carbon tubes. Be careful not to split them! Screw in the sheet metal screws very carefully the first time so as not to damage the carbon tube.

**TIP** You can glue a piece of the 3 mm carbon rod into the 5 mm carbon tube before drilling, this variant is much more durable.

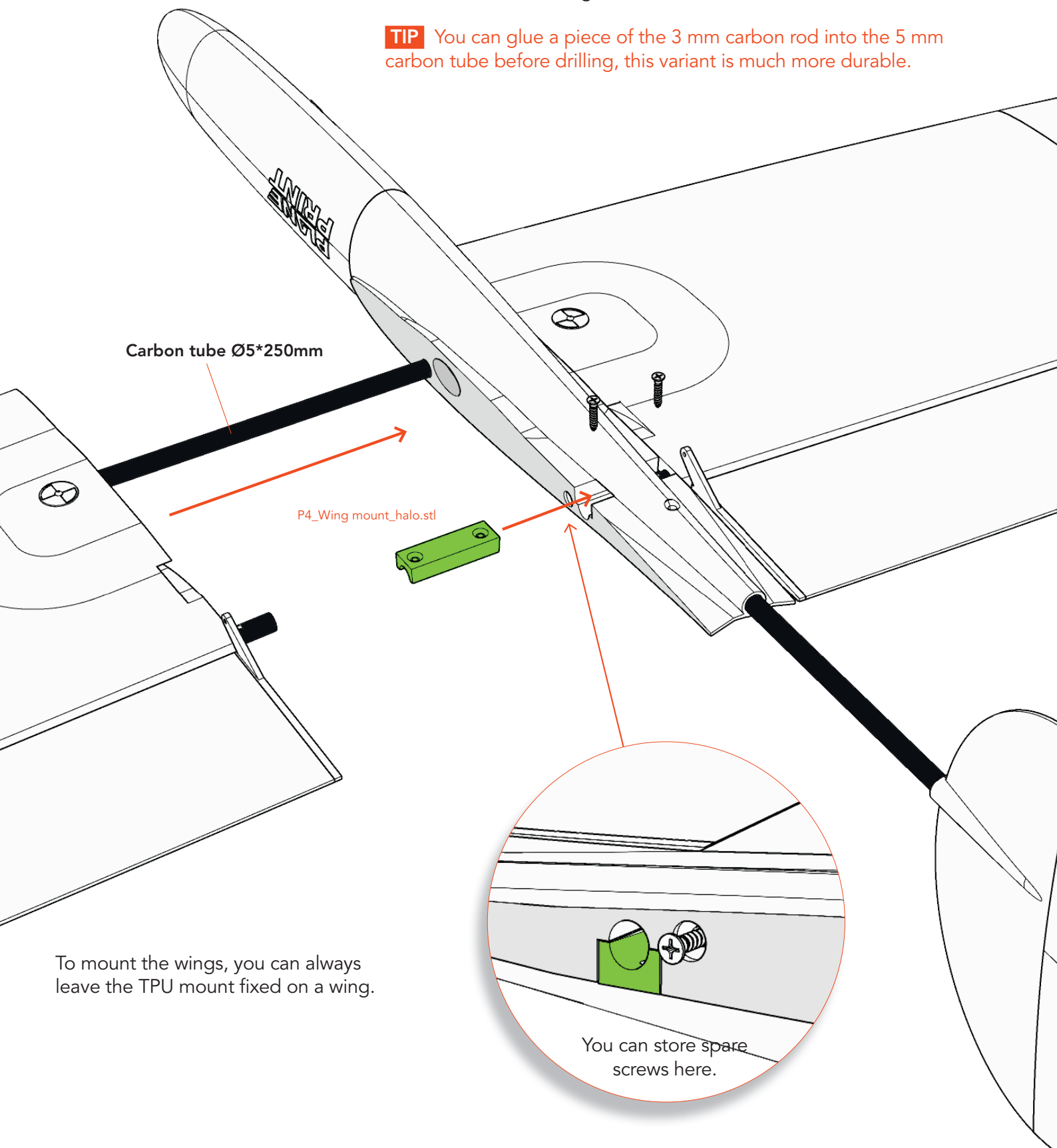

To mount the wings, you can always leave the TPU mount fixed on a wing.

# RC components (glider version)

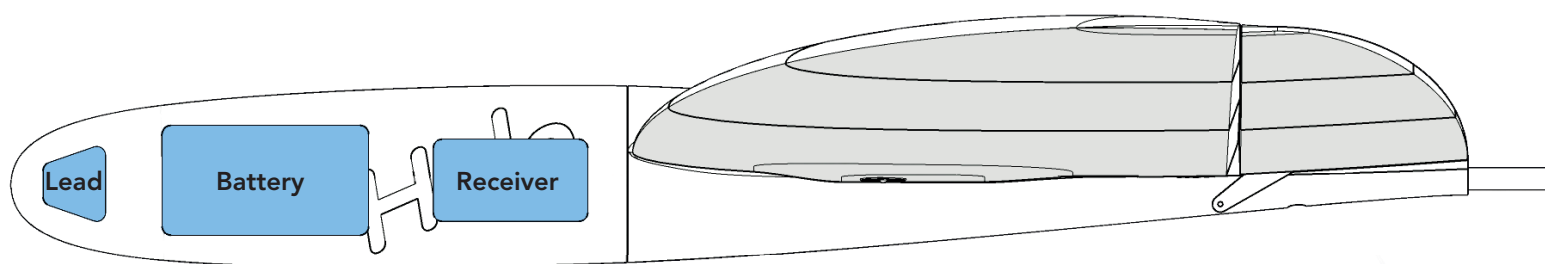

## Center of Gravity (CG)

The aircraft must balance on these points – **see the markings on the wing.**

**For the first flight, the CG should be 50 mm behind the leading edge and then carefully moved backwards.**

**NOTE** The range of optimum CG is particularly small with a flying wing and you have to find the most comfortable CG for yourself in flight. The further forward it is, the easier the model is to fly, the further back the performance is greatest.

Do not forget to check if the wings are exactly in balance in the roll axis. If one wing is heavier, correct this with a small weight on the wingtip.

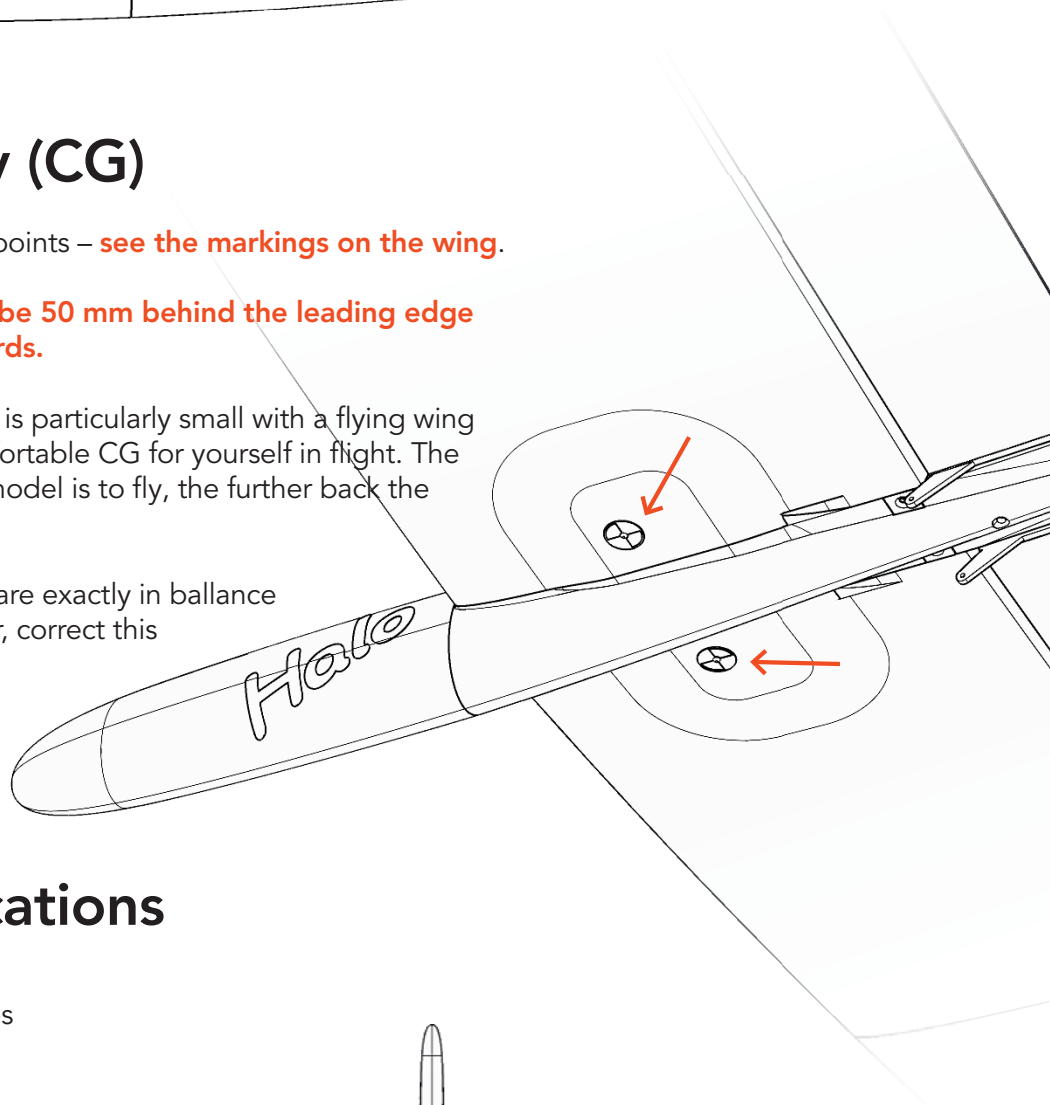

## Technical specifications

**WINGSPAN** 1200 mm/47.2 inches

**LENGTH** 508 mm/20 inches

**FLIGHT WEIGHT** 330 grams

**WING LOAD** 20 g/dm<sup>2</sup>

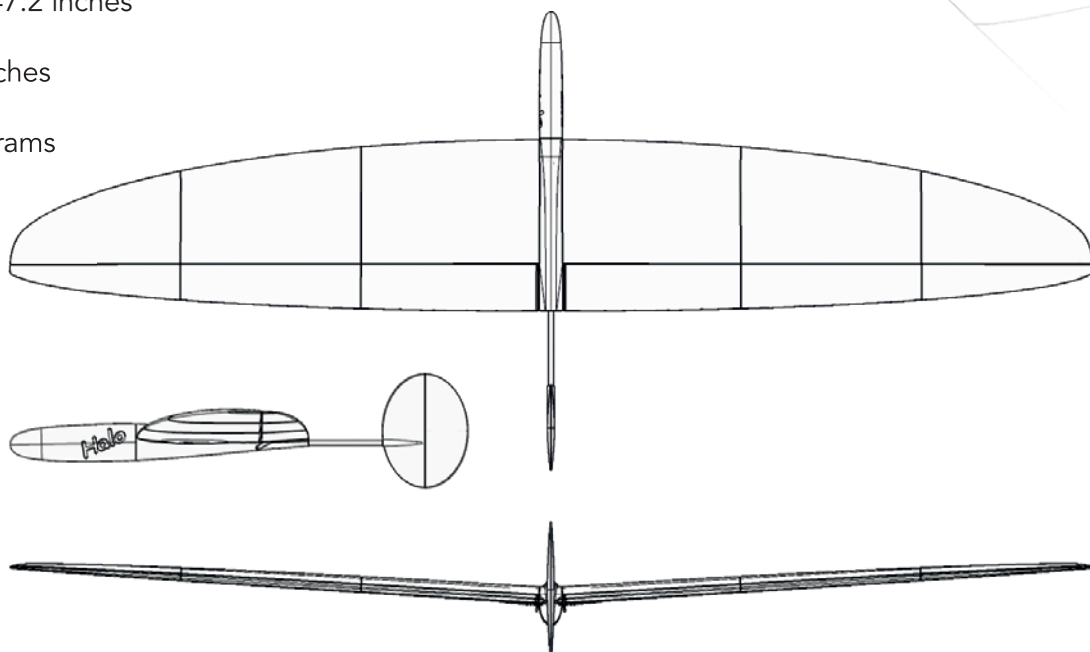

# Control Direction Test Look at the aircraft from behind

As a basic setting (zero position), the ailerons are exactly aligned with the fuselage position.

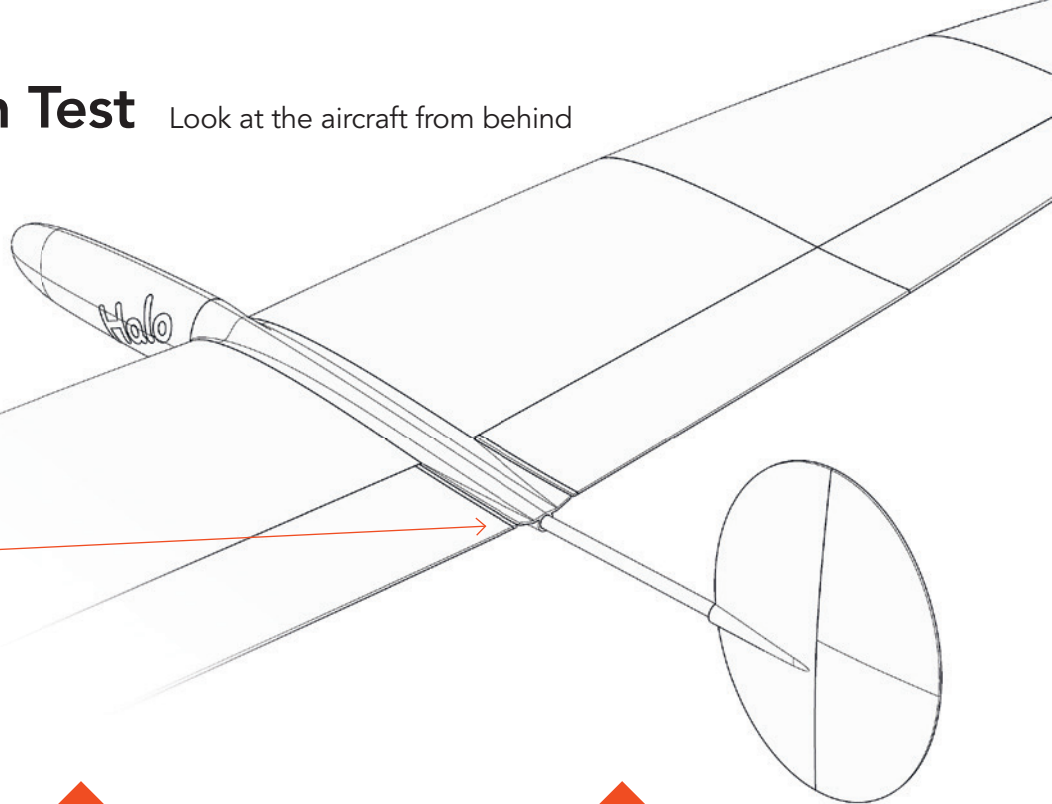

## ELEVATOR



10 to 12 mm

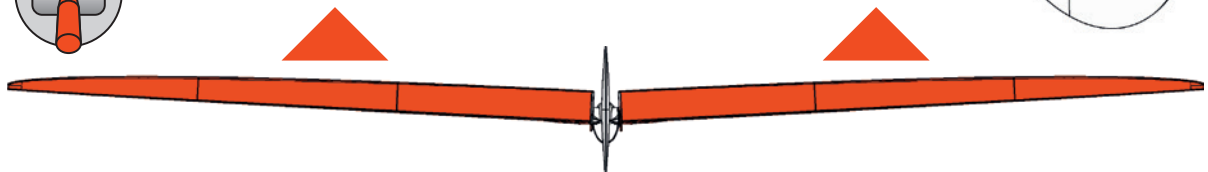

10 to 12 mm

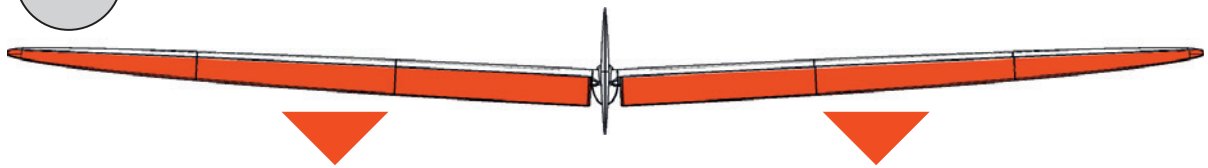

## AILERON

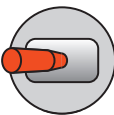

10 to 12 mm

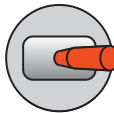
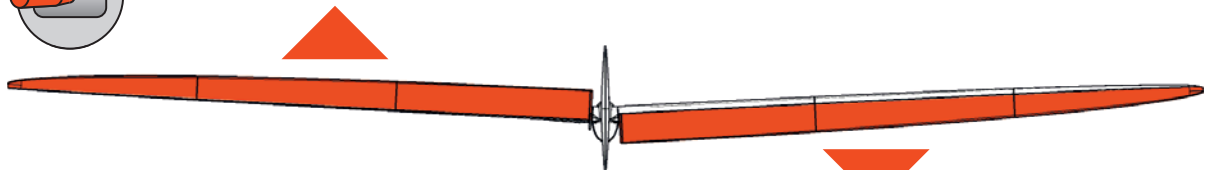

10 to 12 mm

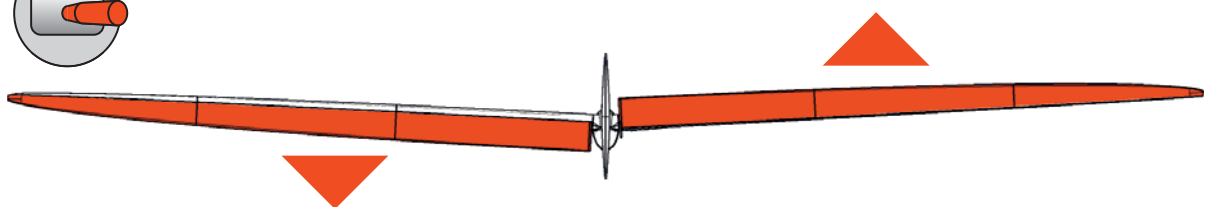

## EXPO

**ELEVATOR** 70 %

**AILERON** 20 %

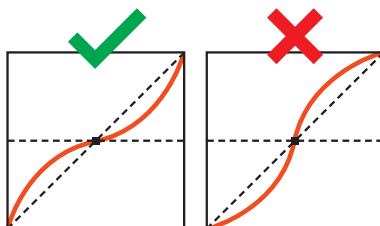

(for some remote controls a minus has to be in front of the number)

# AGE RECOMMENDATION 14+

## NOT FOR CHILDREN UNDER 14 YEARS. THIS IS NOT A TOY!

The STL data (or data processed from it, such as G codes) must never be passed on to third parties!

The purchase of the STL does not authorize the production of models for third parties.

By using the download data, an RC model airplane, called „model“ for short, can be manufactured using a 3D printer. As a user of this model, only you are responsible for safe operation that does not endanger you or others, or that does not damage the model or property of others.

PLANEPRINT.com assumes no responsibility for damage to persons and property caused by pressure, transport or use of the product. Filaments, printing supplies, hardware or consumables that can not be used after faulty 3D printing will not be replaced by PLANEPRINT.com in any way.

When operating, always keep a safe distance from your model in all directions to avoid collisions and injuries.

This model is controlled by a radio signal. Radio signals can be disturbed from outside without being able to influence it. Interference can lead to a temporary loss of control.

Always operate your model on open terrains, far from cars, traffic and people.

Always follow the instructions and warnings for this product and any optional accessories (servos, receivers, motors, propellers, chargers, rechargeable batteries, etc.) carefully.

Keep all chemicals, small parts and electrical components out of the reach of children.

Avoid water contact with all components that are not specially designed and protected. Moisture damages the electronics.

Never take an item of the model or accessory in your mouth as this can lead to severe injuries or even death.

Never operate your model with low batteries in the transmitter or model.

Always keep the model in view and under control. Use only fully charged batteries.

Always keep the transmitter switched on when the model is switched on.

Always remove the battery before disassembling the model.

Keep moving parts clean and dry at all times.

Always allow the parts to cool before touching them.

Always remove the battery after use.

Make sure that the Failsafe is properly set before the flight.

Never operate the model with damaged wiring.

Never touch moving parts.

We develop our models to the best of our knowledge and belief. We accept no liability for consequential damage and injuries caused by improper use or incorrectly printed parts. **Please be careful when handling motors, batteries and propellers** and only move your model with insurance and in approved places!

# PLANE PRINT