

PLANE PRINT

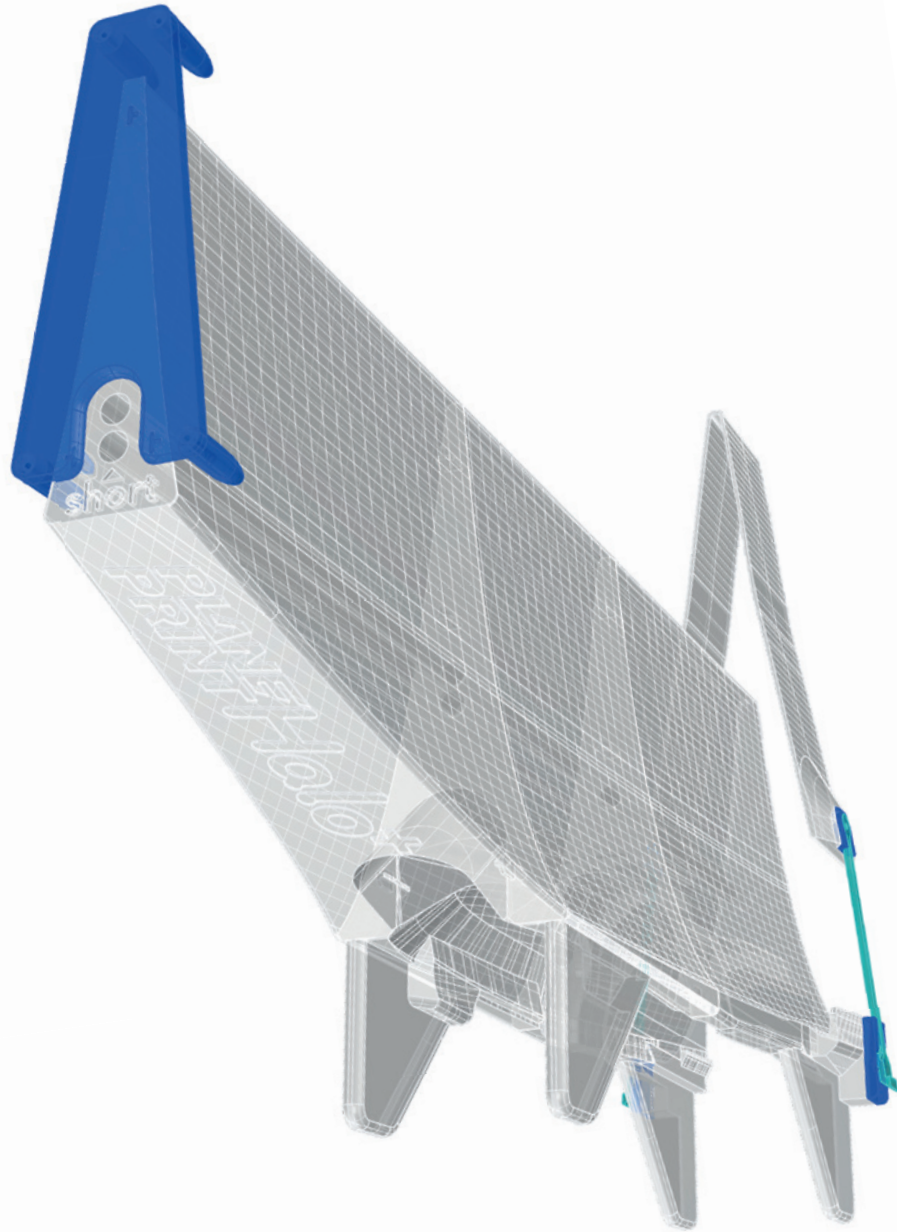

PLANE PRINT *Halo+*

Carry device accessories



www.planepriint.com

the **ONLY** place where you can get original Planeprint STL files **legally!**



The development of a complex, airworthy RC flight model to express on any standard 3D printer is a very extensive process. **Therefore, we appeal to your fairness not to forward the STL data you have acquired to third parties.**

Thank you for your understanding and have fun with your PLANEPRINT MODEL!

Printing the parts – Printing profiles

This manual is constantly being improved and supplemented, we recommend downloading the **latest version** from our website **before building**.

To print all **PLANEPRINT** models **you need to set some basic profiles in Cura** (If you use another slicer, please set the same parameters).

You can find the description at www.planeprint.com/print

For this model you need the following profiles:



PROFILE P5_Gyroid

It is **essential for the necessary stability** of the **LW parts printed with PROFILE_5 are as stable as possible**. Please use a test part to check the strength by fracture tests. It must not break along the layer lines under any circumstances! Also note that the printing temperature for LW-PLA is as low as possible to obtain a wall thickness of 0.4 to 0.6 mm at a flow of 55 to 65 % (depending on brand and printer).

Caution: at too high temperatures, LW-PLA becomes brittle and breaks more easily.

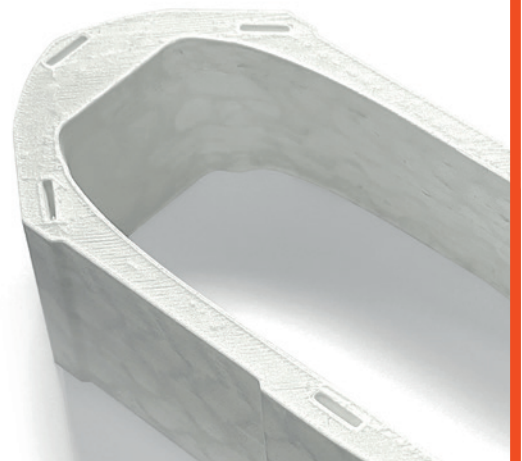

PROFILE P2_Hollowbody Tough PLA or PLA



The information about the basic settings you can find on our website at PRINT.
Please note the additional settings for the individual parts!

P2_Parts_hpc.stl

MATERIAL PLA, Weight: ~ 2 g

ADDITIONAL SETTINGS

None required

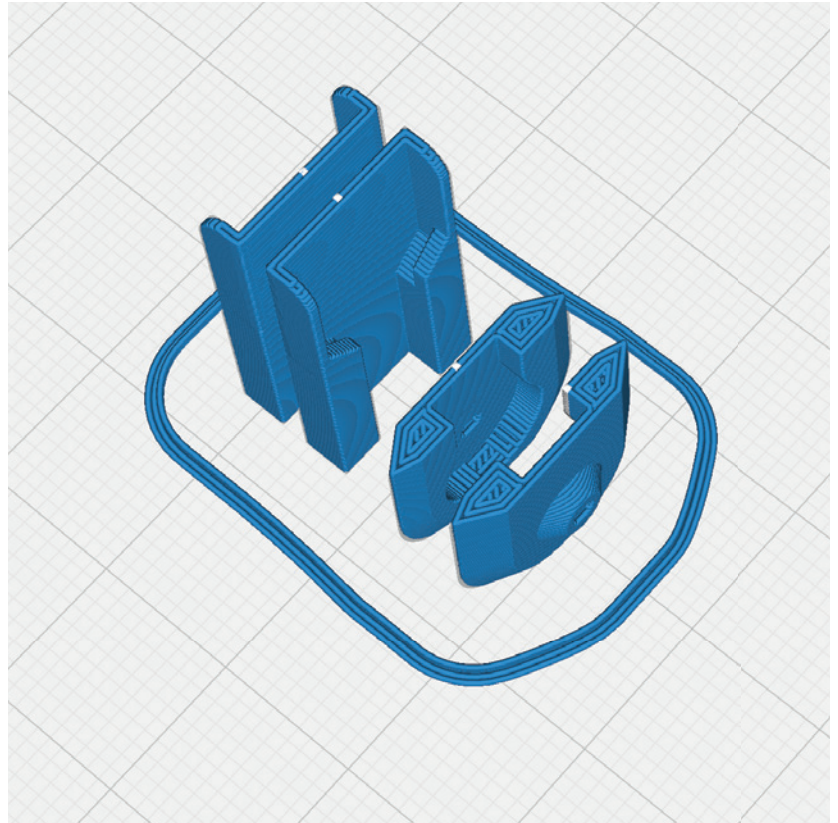

P2_Plate_hpc.stl

MATERIAL PLA, Weight: ~ 6 g

ADDITIONAL SETTINGS

None required

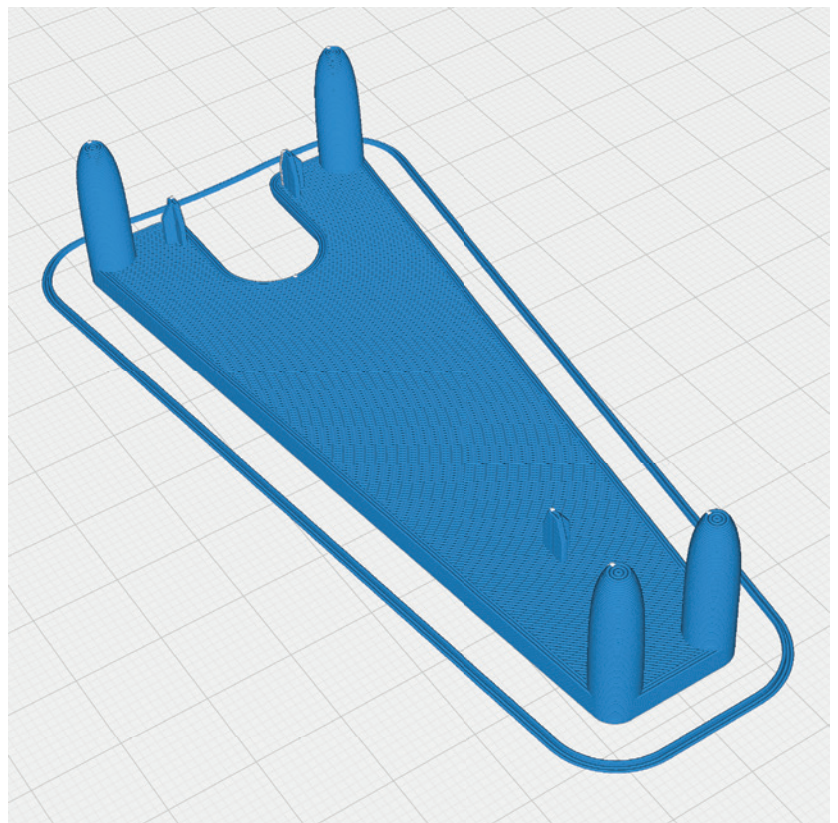

PROFILE P2_Hollowbody Tough PLA or PLA



The information about the basic settings you can find on our website at PRINT.
Please note the additional settings for the individual parts!

P2_T-Connects_hpc.stl

MATERIAL PLA, Weight: ~ 1 g

ADDITIONAL SETTINGS

None required

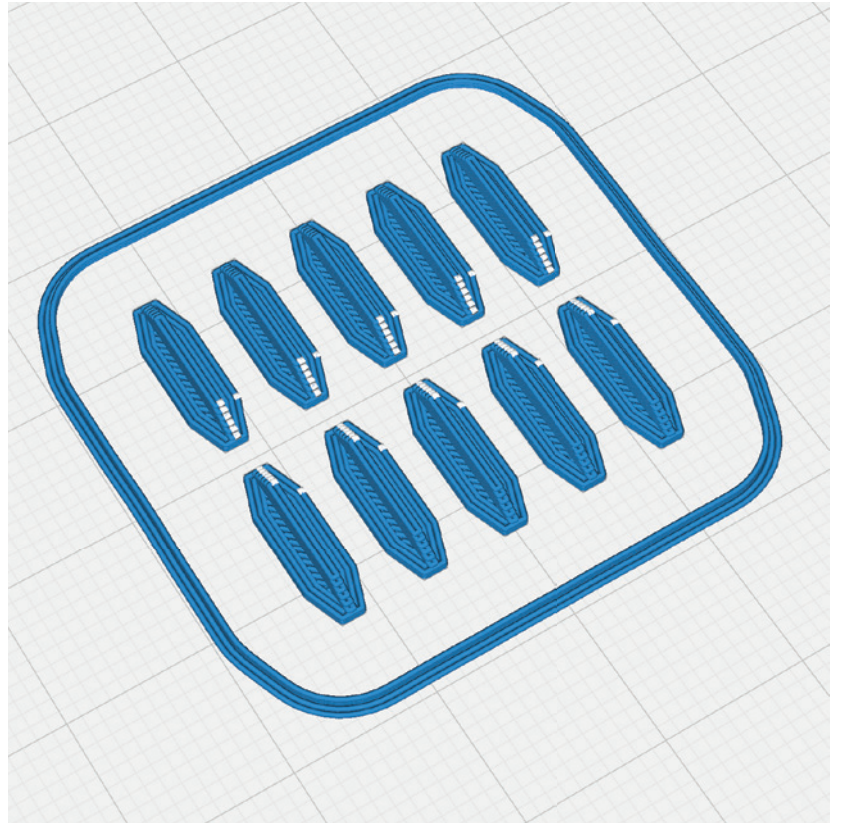

PROFILE P5_Gyroid LW-PLA (foaming)!



The information about the basic settings you can find on our website at PRINT.

Please note the additional settings for the individual parts!

It is essential to print these parts with foaming LW-PLA (pre-foamed is heavier)!

Basic settings for LW-PLA: Please follow the instructions in our **WINGTEST AND CALIBRATION TOOL** on our website for correct adjustment! Print only one STL at a time!

P5_Carry1_hpc.stl

MATERIAL LW PLA, Weight: ~ 25 g

ADDITIONAL SETTINGS

None required

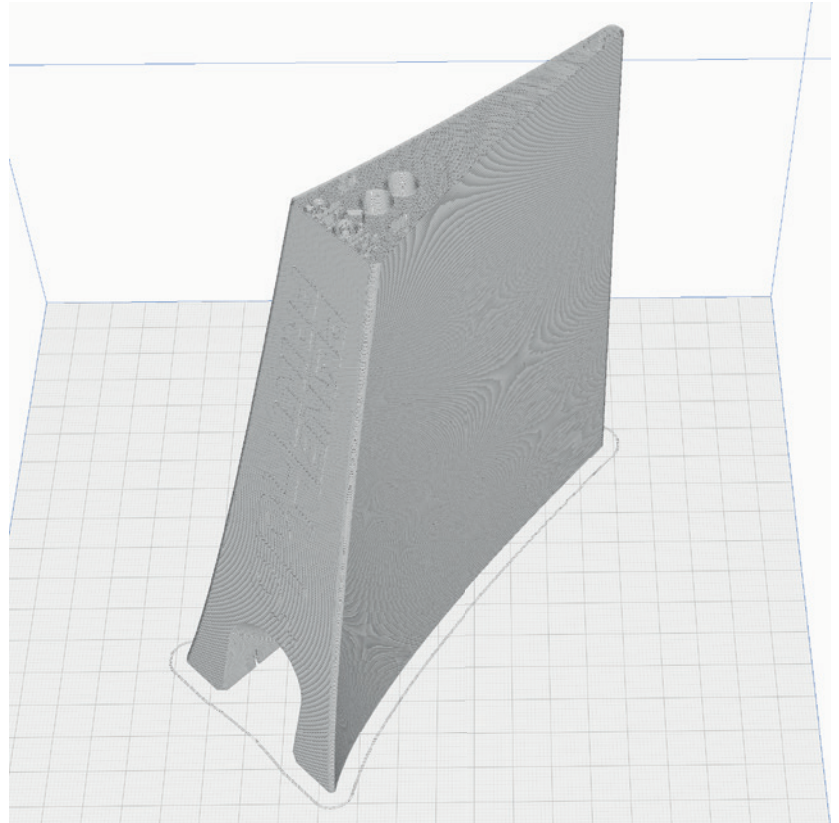

P5_Carry2_hpc.stl

MATERIAL LW PLA, Weight: ~ 25 g

ADDITIONAL SETTINGS

None required

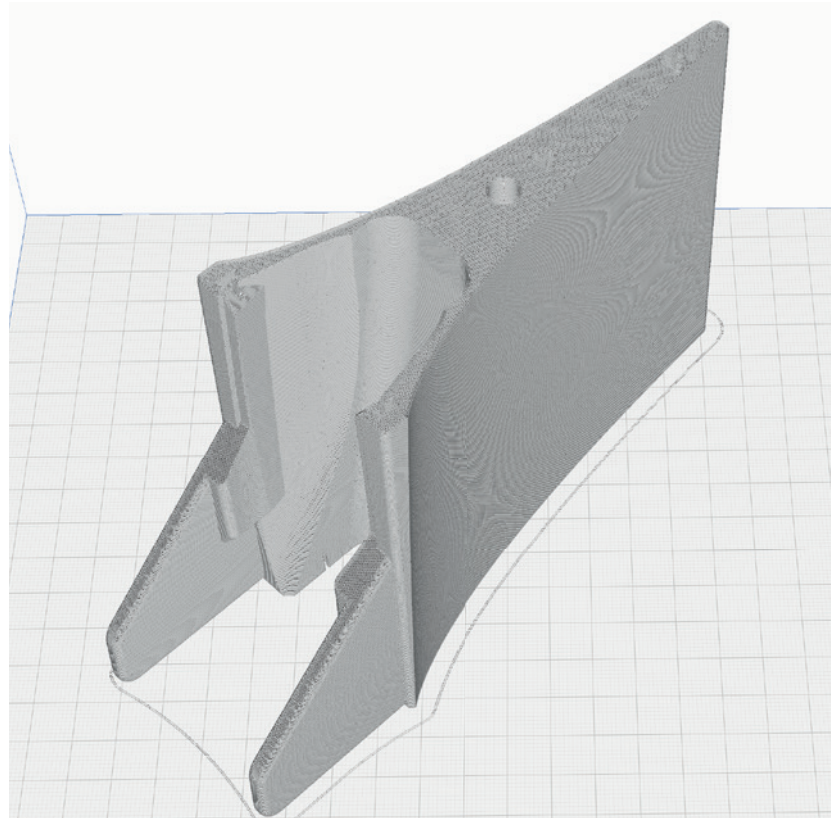

PROFILE P5_Gyroid LW-PLA (foaming)!



The information about the basic settings you can find on our website at PRINT.

Please note the additional settings for the individual parts!

It is essential to print these parts with foaming LW-PLA (pre-foamed is heavier)!

Basic settings for LW-PLA: Please follow the instructions in our **WINGTEST AND CALIBRATION TOOL** on our website for correct adjustment! Print only one STL at a time!

P5_Carry3_hpc.stl

MATERIAL LW PLA, Weight: ~ 30 g

ADDITIONAL SETTINGS

None required

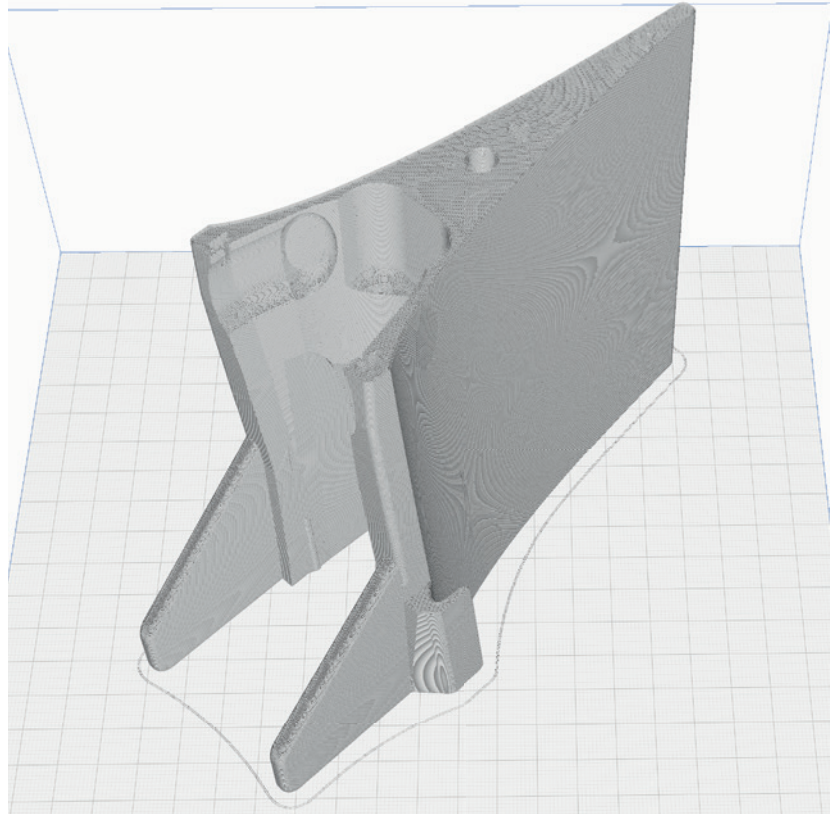

P5_Wing Clip_hpc.stl

MATERIAL LW PLA, Weight: ~ 8 g

ADDITIONAL SETTINGS

None required

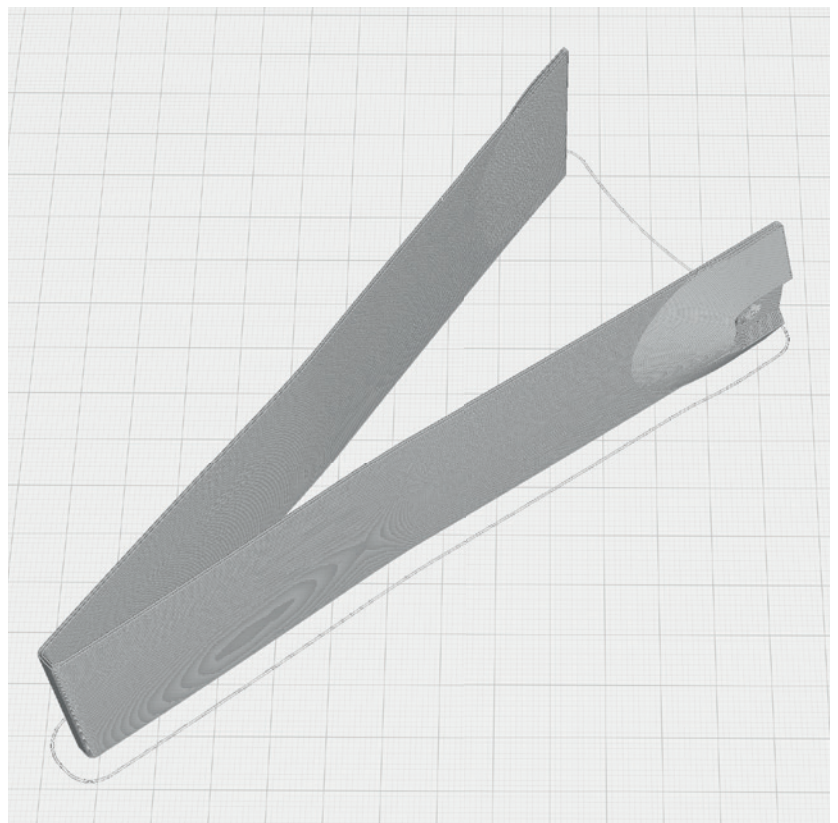

PROFILE P4_Flex LW TPU (A95/VarioShore)



The information about the basic settings you can find on our website at PRINT.
Please note the additional settings for the individual parts!

P4_Wing Belt_hp.stl

MATERIAL TPU, Weight: ~ 1 g

ADDITIONAL SETTINGS

- Wall Line Count/Perimeters: 10
- Print it 2 times

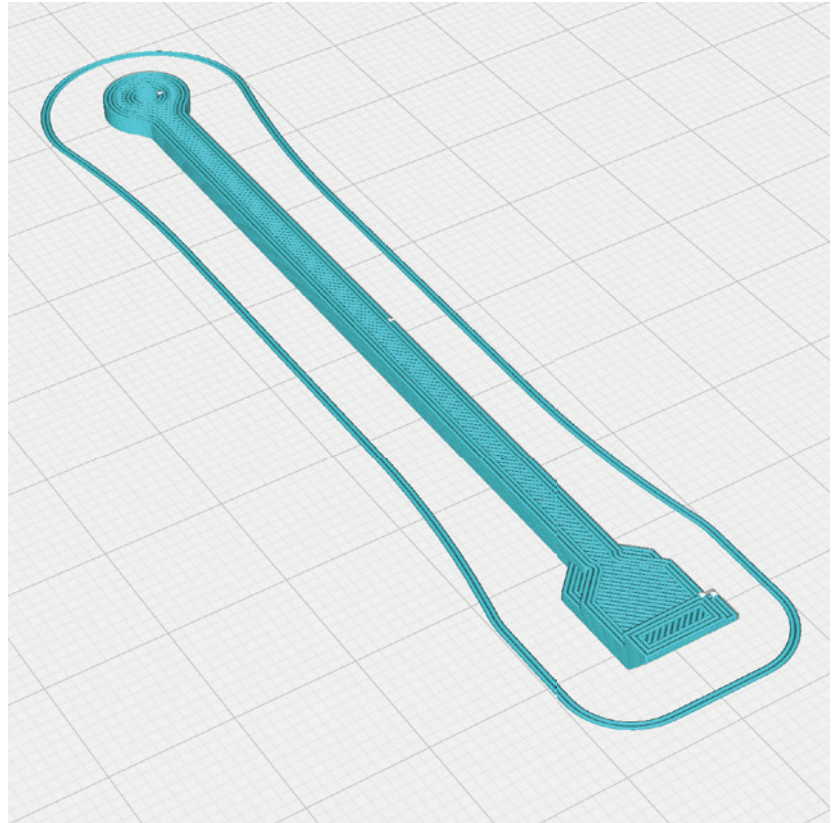

Assembly



TIP Always put all parts together **BEFORE** gluing and check that everything runs smoothly and fits exactly.

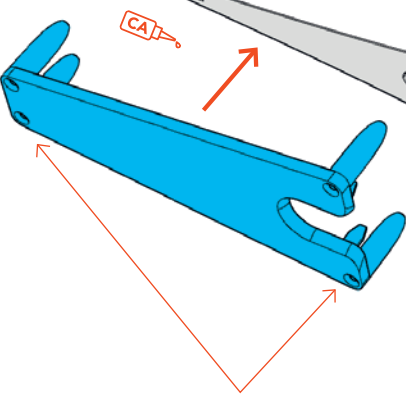
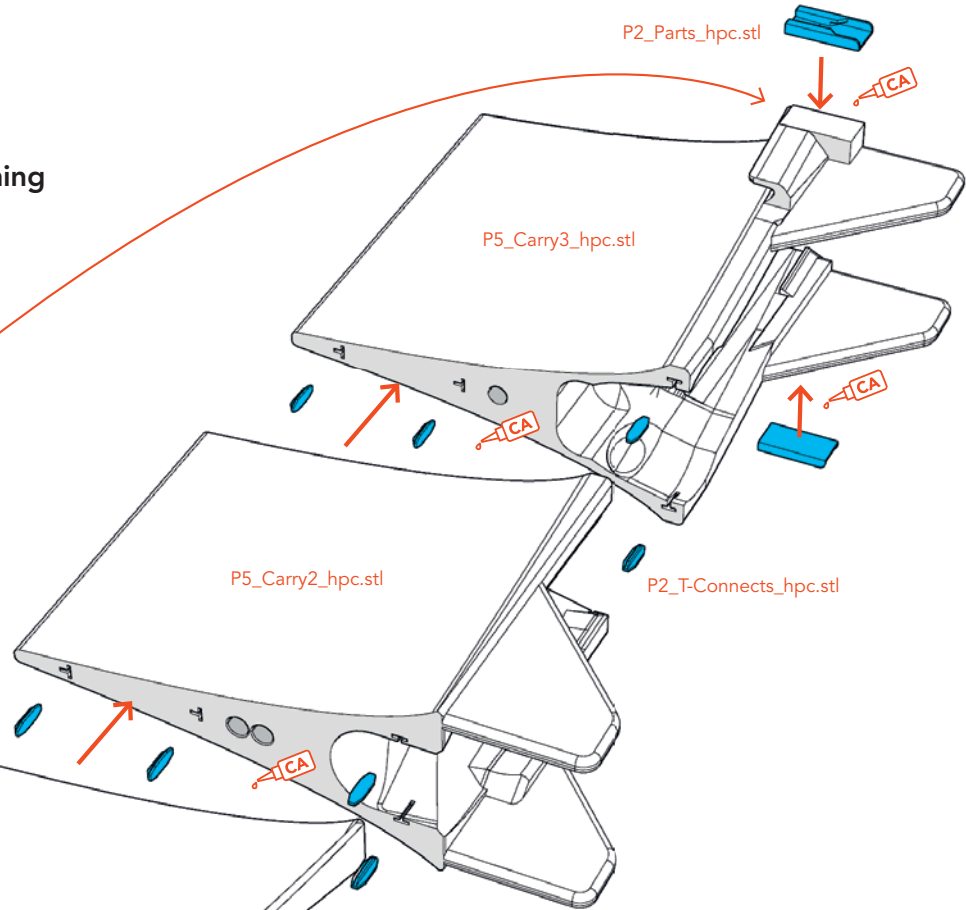
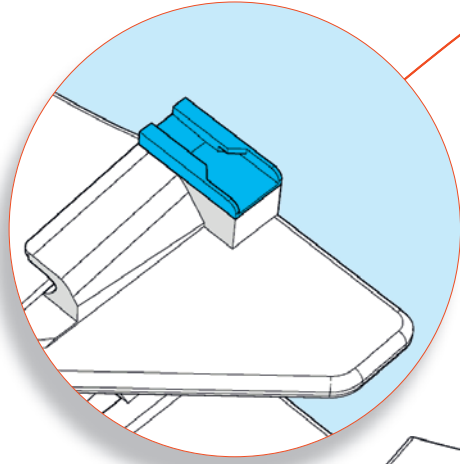

You can use tapping screws here for reinforcement.

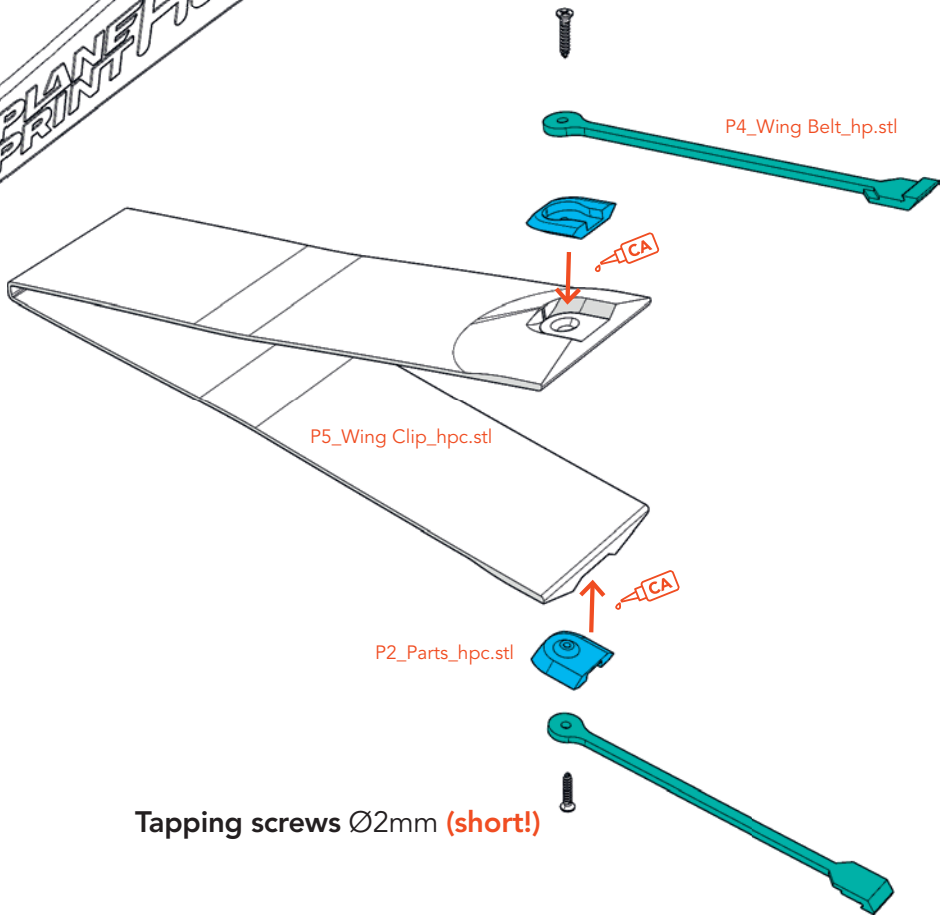

Tapping screws \varnothing 2mm (short!)

Fastening

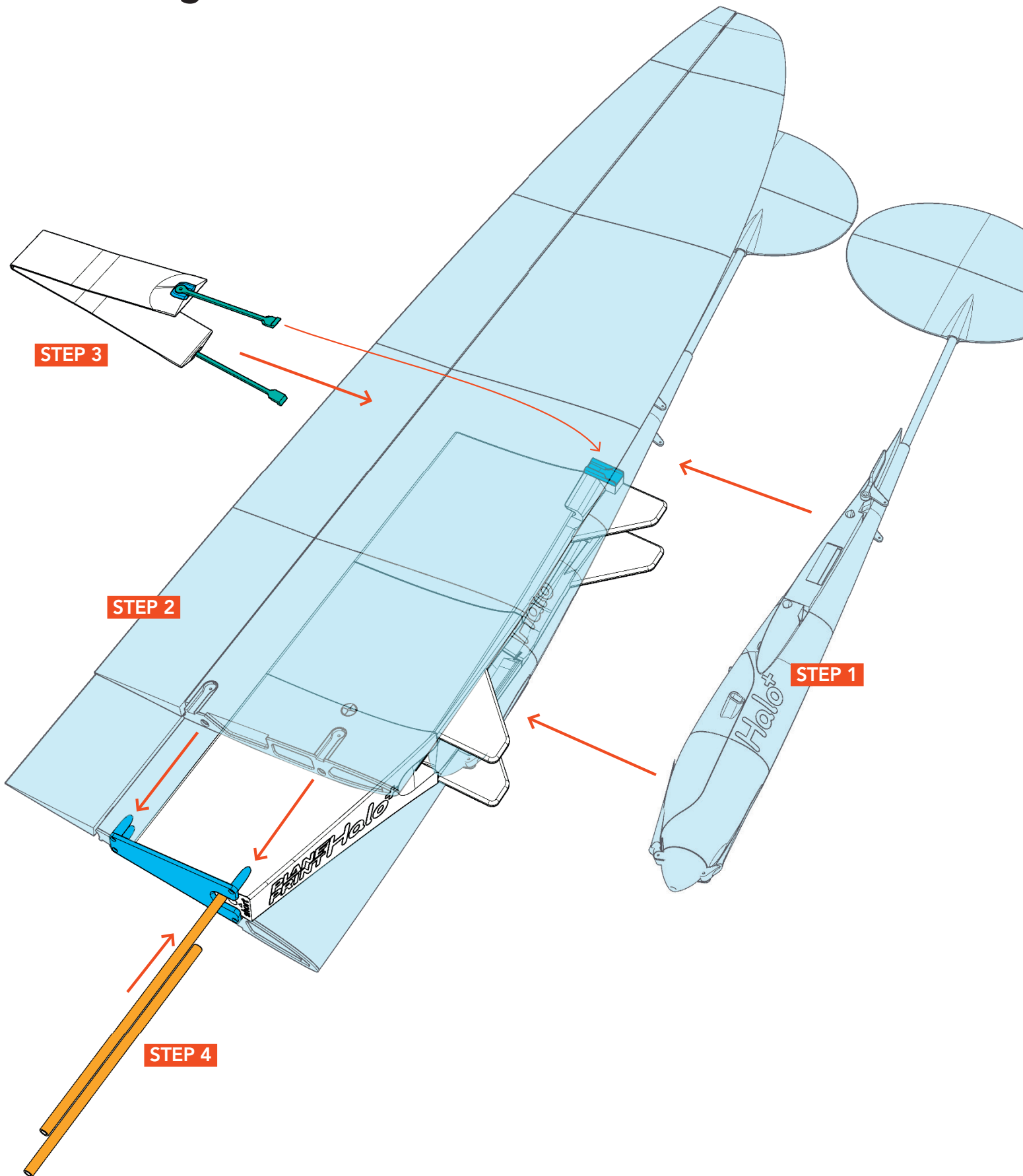

AGE RECOMMENDATION 14+

NOT FOR CHILDREN UNDER 14 YEARS. THIS IS NOT A TOY!

The STL data (or data processed from it, such as G codes) must never be passed on to third parties!

The purchase of the STL does not authorize the production of models for third parties.

By using the download data, an RC model airplane, called „model“ for short, can be manufactured using a 3D printer. As a user of this model, only you are responsible for safe operation that does not endanger you or others, or that does not damage the model or property of others.

PLANEPRINT.com assumes no responsibility for damage to persons and property caused by pressure, transport or use of the product. Filaments, printing supplies, hardware or consumables that can not be used after faulty 3D printing will not be replaced by PLANEPRINT.com in any way.

When operating, always keep a safe distance from your model in all directions to avoid collisions and injuries.

This model is controlled by a radio signal. Radio signals can be disturbed from outside without being able to influence it. Interference can lead to a temporary loss of control.

Always operate your model on open terrains, far from cars, traffic and people.

Always follow the instructions and warnings for this product and any optional accessories (servos, receivers, motors, propellers, chargers, rechargeable batteries, etc.) carefully.

Keep all chemicals, small parts and electrical components out of the reach of children.

Avoid water contact with all components that are not specially designed and protected. Moisture damages the electronics.

Never take an item of the model or accessory in your mouth as this can lead to severe injuries or even death.

Never operate your model with low batteries in the transmitter or model.

Always keep the model in view and under control. Use only fully charged batteries.

Always keep the transmitter switched on when the model is switched on.

Always remove the battery before disassembling the model.

Keep moving parts clean and dry at all times.

Always allow the parts to cool before touching them.

Always remove the battery after use.

Make sure that the Failsafe is properly set before the flight.

Never operate the model with damaged wiring.

Never touch moving parts.

We develop our models to the best of our knowledge and belief. We accept no liability for consequential damage and injuries caused by improper use or incorrectly printed parts. **Please be careful when handling motors, batteries and propellers** and only move your model with insurance and in approved places!

PLANE PRINT