

NOTOS



NOTE: Slicing only works with CURA!



You can find the STL data at www.planeprint.com

PRINTING THE PARTS – PRINTING PROFILES

You may wonder why this 3D model is suitable exclusively for CURA right?

The most important thing about small RC model airplanes is always the ratio of size to weight. The lighter a model is, the better its flight characteristics and also the flight time is significantly increased.

With our unique design process, we manage to make Weights relevant items in a **true 1-wall printing process** for the outer skin but also for the filling offer. So we save weight while maintaining the necessary stability.

Here we show you how to get started from a standard CURA profile Make settings. For this model we only need 4, easy to create profiles.

It is **absolutely necessary** to observe the information provided by **PLANEPRINT.com** in order: to slice the component correctly. However, it may make sense to perfect your 3D printing by additionally performing several hiring activities depending on your printer and the filament used.

For slicing all Planeprint models, four profiles have to be created in Cura:

PROFILE P1_fullbody
PROFILE P2_hollowbody
PROFILE P3_surface
PROFILE P4_flex

You can find the description at www.planeprint.com/print

IMPORTANT FOR THE 1-WALL-PRINT!

In order to print airfoils of the lowest possible weight with high stability, it is necessary to print with only one wall line (Nozzle 0.4 mm). Decisive here is the adhesion between the layers! To achieve this, you must print at a much higher temperature than normal. As a **guideline**, 230 ° C is a good starting point. The parts-cooling fan should be set to 0% or a maximum of 20%. Since not every printer works the same, it may be necessary to make small adjustments to these settings.



The development of a complex, airworthy RC flight model to express on any standard 3D printer is a very complex and extensive process. Therefore, we appeal to your fairness not to forward the STL data you have acquired to third parties. Our STL files are provided with indelible copyright watermarks that can be verified at any time.

Thank you for your understanding and have fun with your PLANEPRINT MODEL!

PROFILE P1_FULLBODY

The following parts must be sliced with the PROFILE P1_FULLBODY.
Please note the additional settings for the individual parts!

N_AOA-adjuster_profile1.stl

MATERIAL PLA, Weight: ~ 10 g

ADDITIONAL SETTINGS

None required

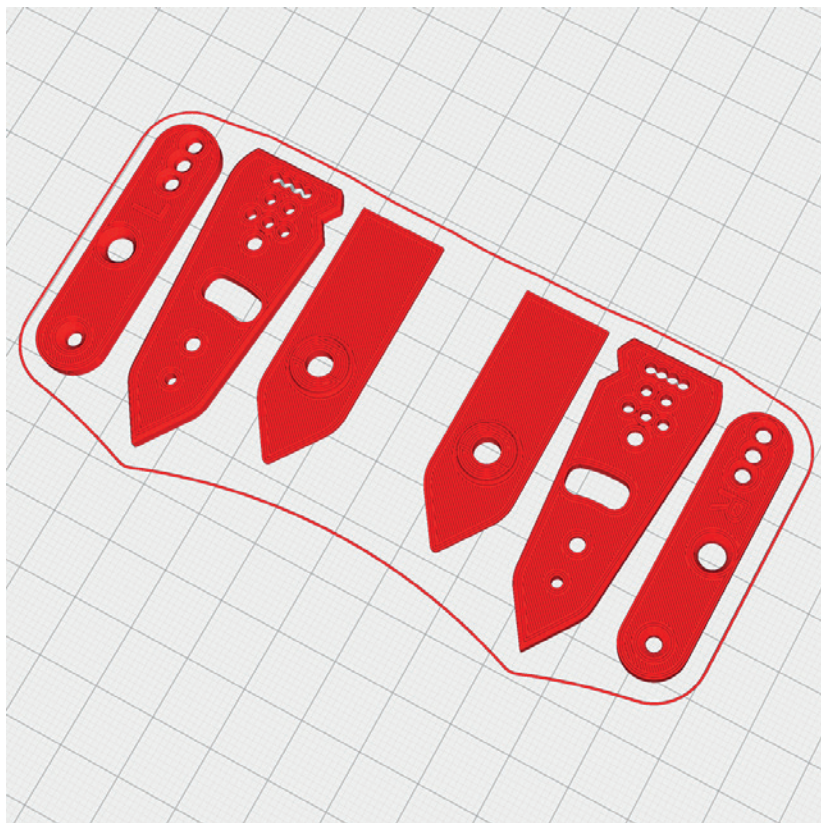

N_Motorbracket_profile1.stl

MATERIAL PLA, ~ 5 g

ADDITIONAL SETTINGS

None required

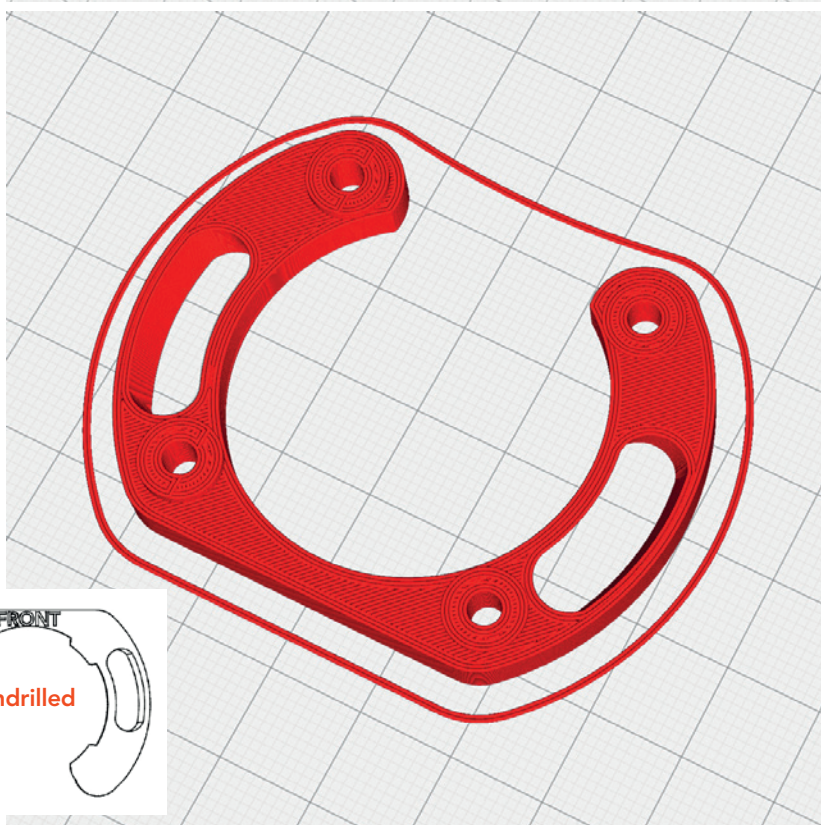

There are several versions to choose from:

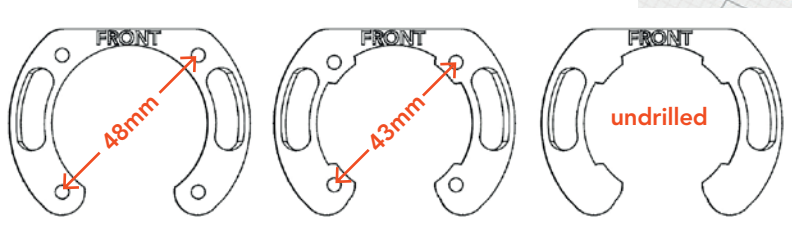

PROFILE P1_FULLBODY

The following parts must be sliced with the PROFILE P1_FULLBODY.
Please note the additional settings for the individual parts!

N_Parts_profile1.stl

MATERIAL PLA, ~ 7 g

ADDITIONAL SETTINGS

None required



N_Servobrackets-xxx_profile1.stl

MATERIAL PLA, ~ 16 g

ADDITIONAL SETTINGS

None required

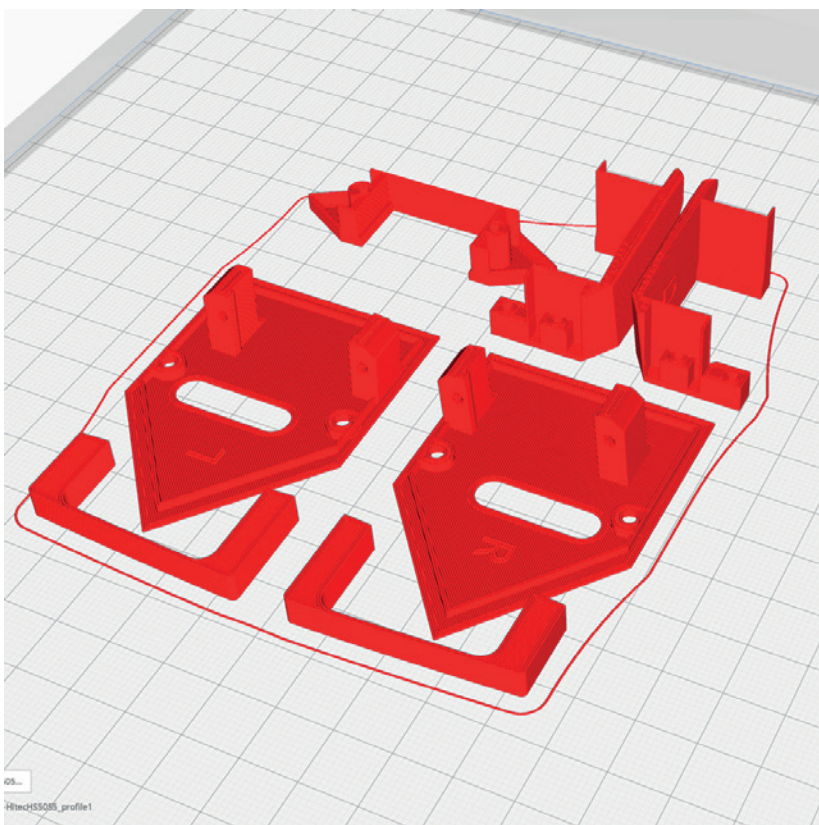

PROFILE P1_FULLBODY

The following parts must be sliced with the PROFILE P1_FULLBODY.
Please note the additional settings for the individual parts!

N_Spinner2_profile1.stl

MATERIAL PLA, ~ 8 g

ADDITIONAL SETTINGS

None required

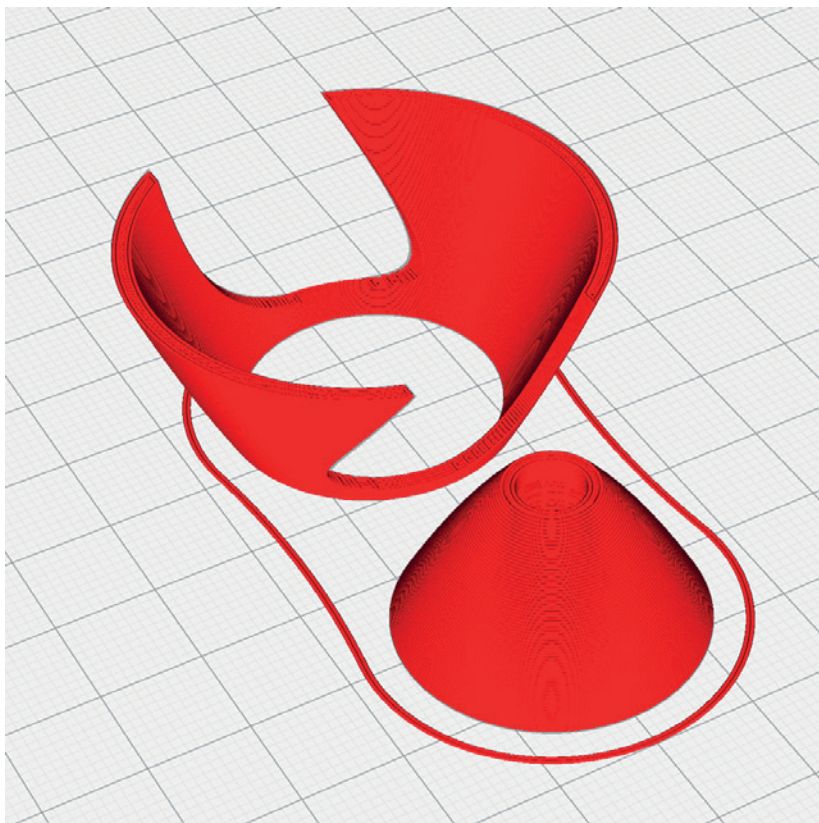

N_Spinnerplate1_profile1.stl

MATERIAL PLA, ~ 3 g

ADDITIONAL SETTINGS

None required

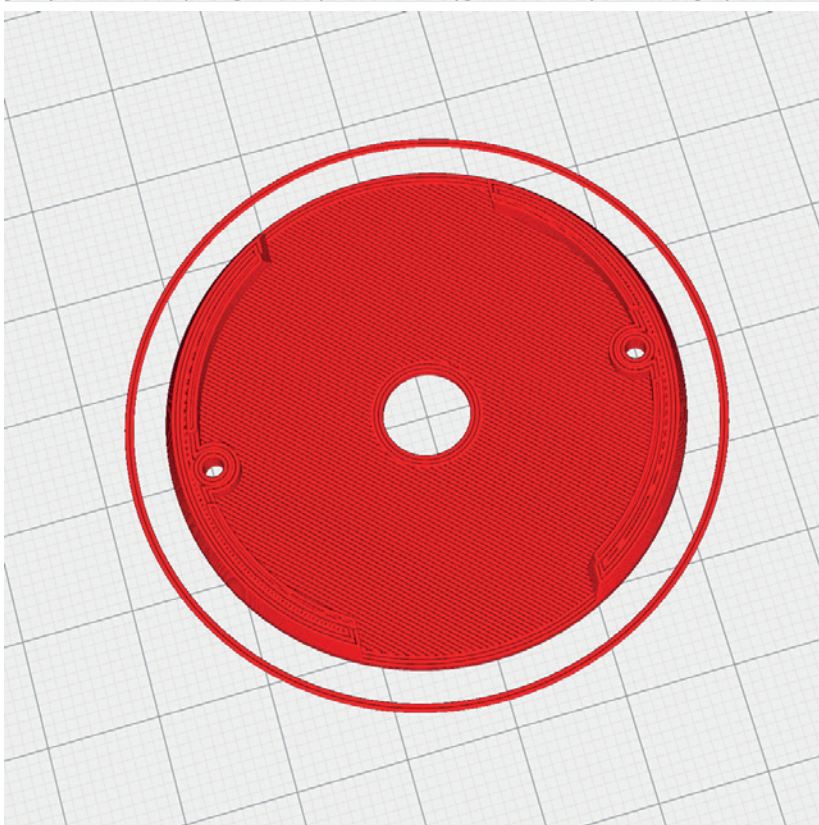

PROFILE P2_HOLLOWBODY

The following parts must be sliced with the PROFILE P2_HOLLOWBODY.
Please note the additional settings for the individual parts!

N_Battery holder_profile2.stl

MATERIAL PLA, ~ 9 g

ADDITIONAL SETTINGS

- Wall Line Count: 5

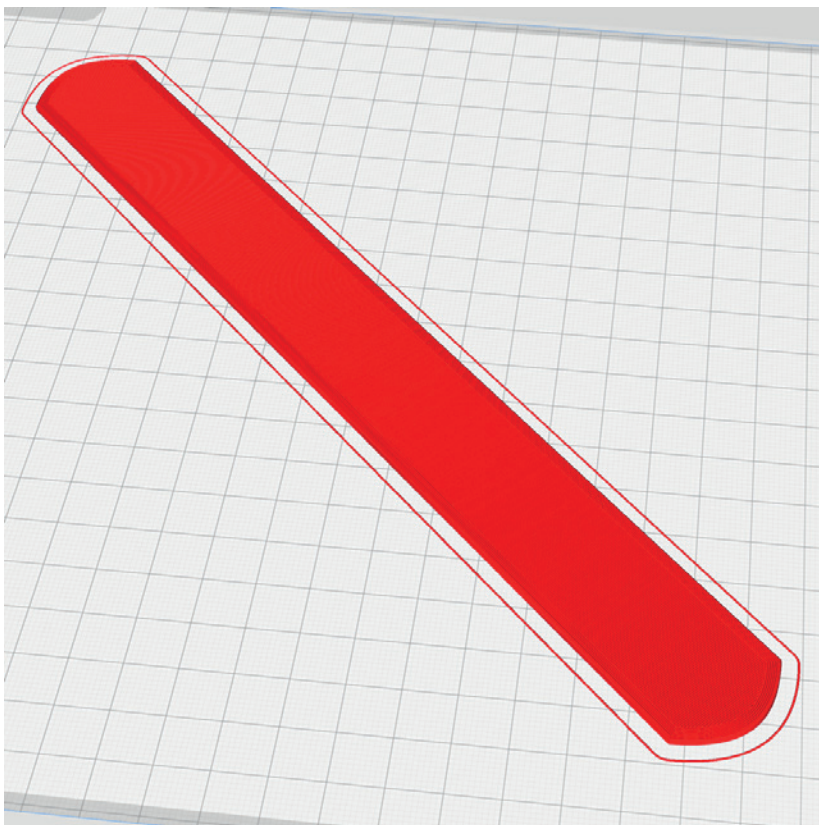

N_Gear1_profile2.stl

MATERIAL PLA, ~ 21 g

ADDITIONAL SETTINGS

- Wall Line Count: 3
- Top Layers: 3

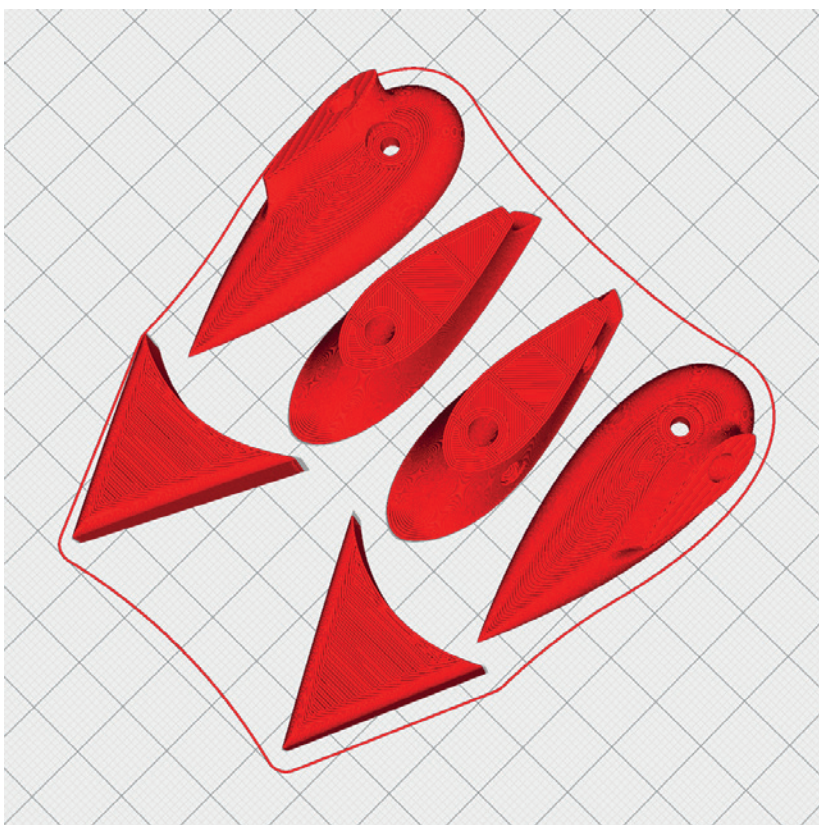

PROFILE P2_HOLLOWBODY

The following parts must be sliced with the PROFILE P2_HOLLOWBODY.
Please note the additional settings for the individual parts!

N_R-Hinge_profile2.stl

MATERIAL PLA, ~ 4 g

ADDITIONAL SETTINGS

- Adaptive Layers: checked

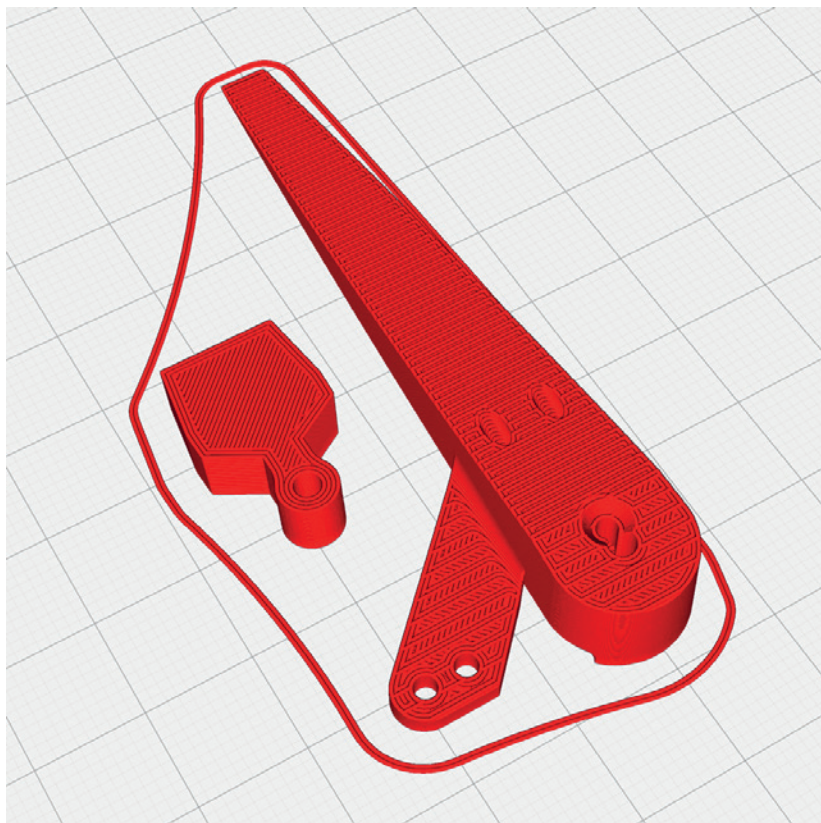

PROFILE P3_SURFACE normal PLA

The following parts must be sliced with the PROFILE P3_SURFACE (1-wall-print).

Please note the additional settings for the individual parts!

PLEASE NOTE In profile P3_SURFACE, there should not be more than one STL on the buildplate at the same time, otherwise slicing errors can occur! Depending on your printer, a brim may not be required.

N_Elevator2_profile3.stl

MATERIAL PLA, ~ 2 g

ADDITIONAL SETTINGS

None required

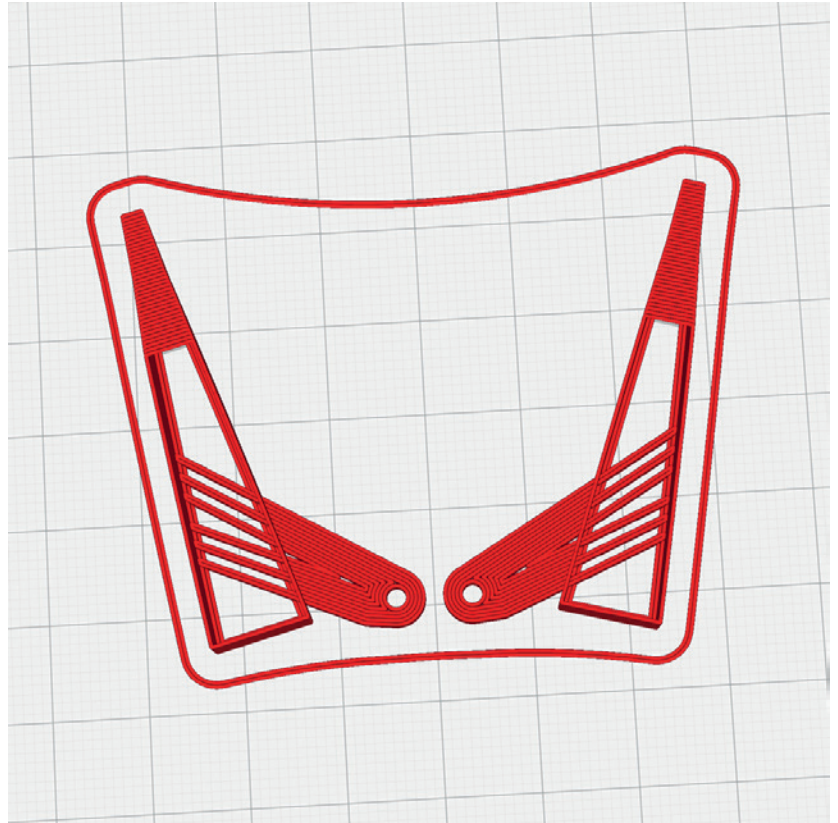

N_Fuselage1_profile3.stl

MATERIAL PLA, ~ 81 g

ADDITIONAL SETTINGS

None required

- Set brim

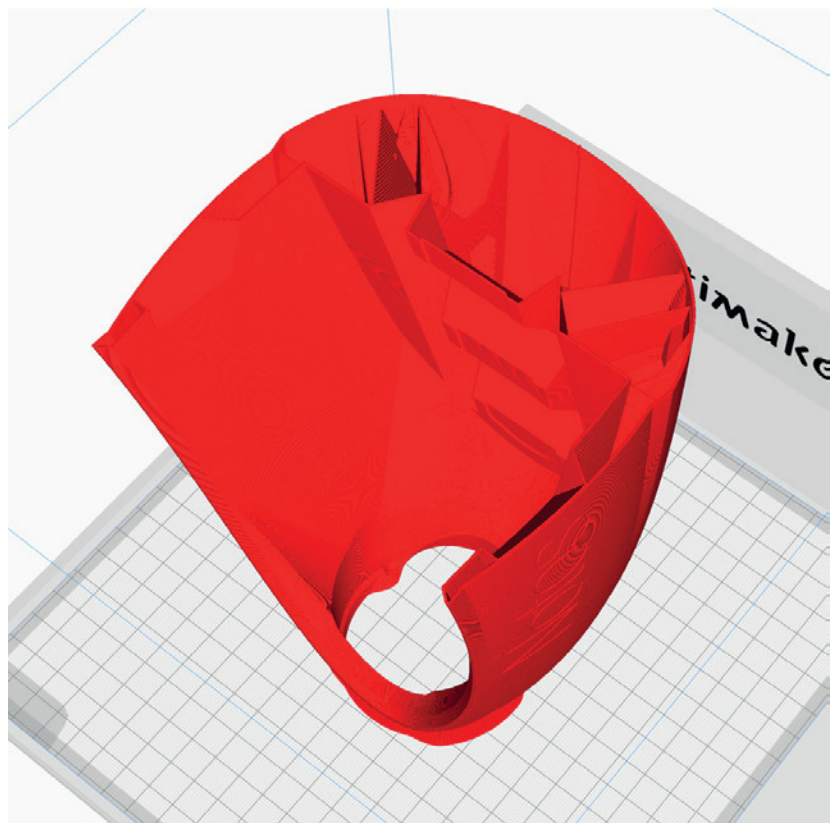

PROFILE P3_SURFACE normal PLA

The following parts must be sliced with the PROFILE P3_SURFACE (1-wall-print).

Please note the additional settings for the individual parts!

PLEASE NOTE In profile P3_SURFACE, there should not be more than one STL on the buildplate at the same time, otherwise slicing errors can occur! Depending on your printer, a brim may not be required.

N_Fuselage2_profile3.stl

MATERIAL PLA, ~ 92 g

ADDITIONAL SETTINGS

None required

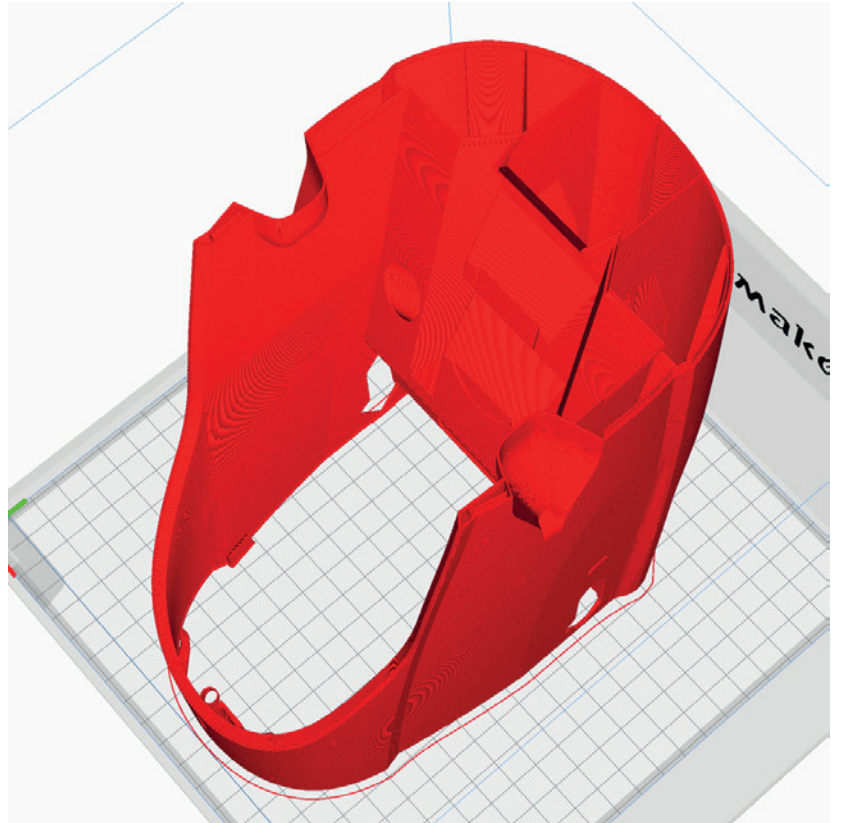

N_Spinner1_profile3.stl

MATERIAL PLA, ~ 3 g

ADDITIONAL SETTINGS

None required



PROFILE P3_SURFACE normal PLA

The following parts must be sliced with the PROFILE P3_SURFACE (1-wall-print).

Please note the additional settings for the individual parts!

PLEASE NOTE In profile P3_SURFACE, there should not be more than one STL on the buildplate at the same time, otherwise slicing errors can occur! Depending on your printer, a brim may not be required.

N_Wing1-left/right_profile3.stl

MATERIAL PLA, ~ 27 g

ADDITIONAL SETTINGS

Wing left: • Z Seam Position right

Wing right: • Z Seam Position left

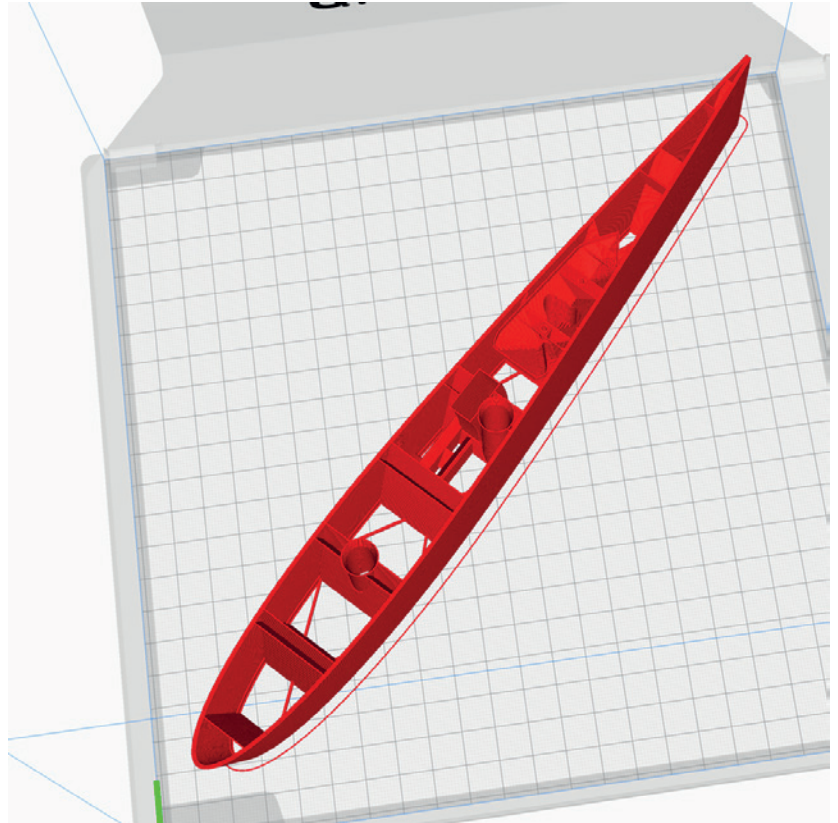

PROFILE P3_SURFACE Light-Weight LW-PLA

The following parts must be sliced with the PROFILE P3_SURFACE (1-wall-print).

Please note the additional settings for the individual parts!

PLEASE NOTE In profile P3_SURFACE, there should not be more than one STL on the buildplate at the same time, otherwise slicing errors can occur! Depending on your printer, a brim may not be required.

N_Aileron1-left/right-LW_profile3.stl

MATERIAL LW-PLA, ~ 11 g*

*Display in Cura. The actual weight is then 60% of this.

ADDITIONAL SETTINGS

- Setting Profile3_Surface
- Flow 60 % or less
- Higher nozzle temperature

The optimal weight and sufficient strength is achieved with 60 % flow. Increase the temperature until the wall thickness is 0.4 to 0.5 mm. (We print at 235° and 60% flow).

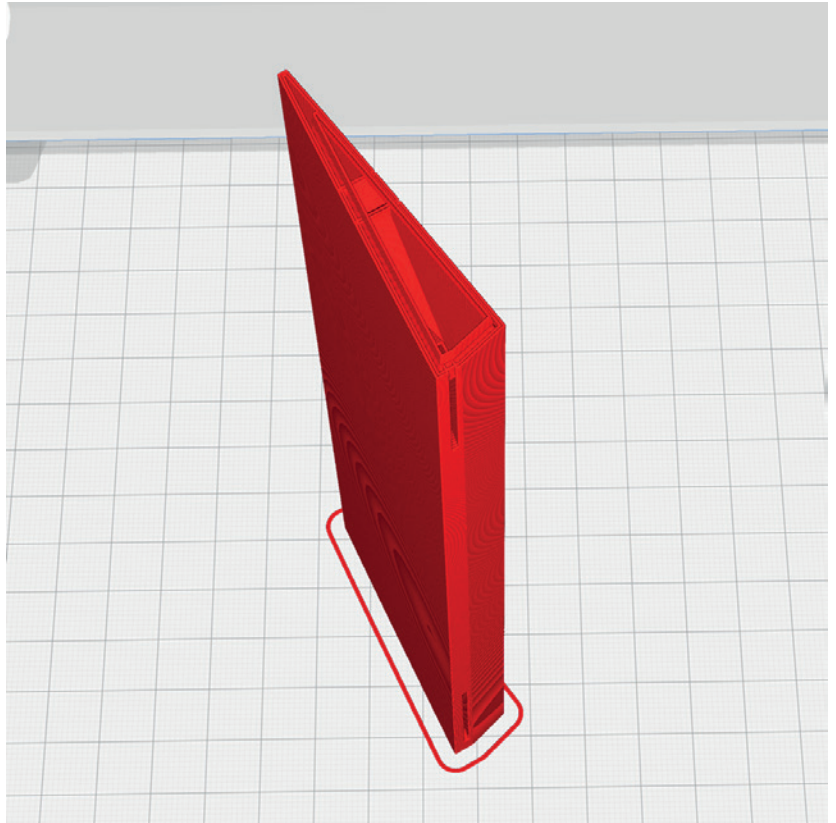

N_Aileron2-left/right-LW_profile3.stl

MATERIAL LW-PLA, ~ 11 g*

*Display in Cura. The actual weight is then 60% of this.

ADDITIONAL SETTINGS

- Setting Profile3_Surface
- Flow 60 % or less
- Higher nozzle temperature

The optimal weight and sufficient strength is achieved with 60 % flow. Increase the temperature until the wall thickness is 0.4 to 0.5 mm. (We print at 235° and 60% flow).

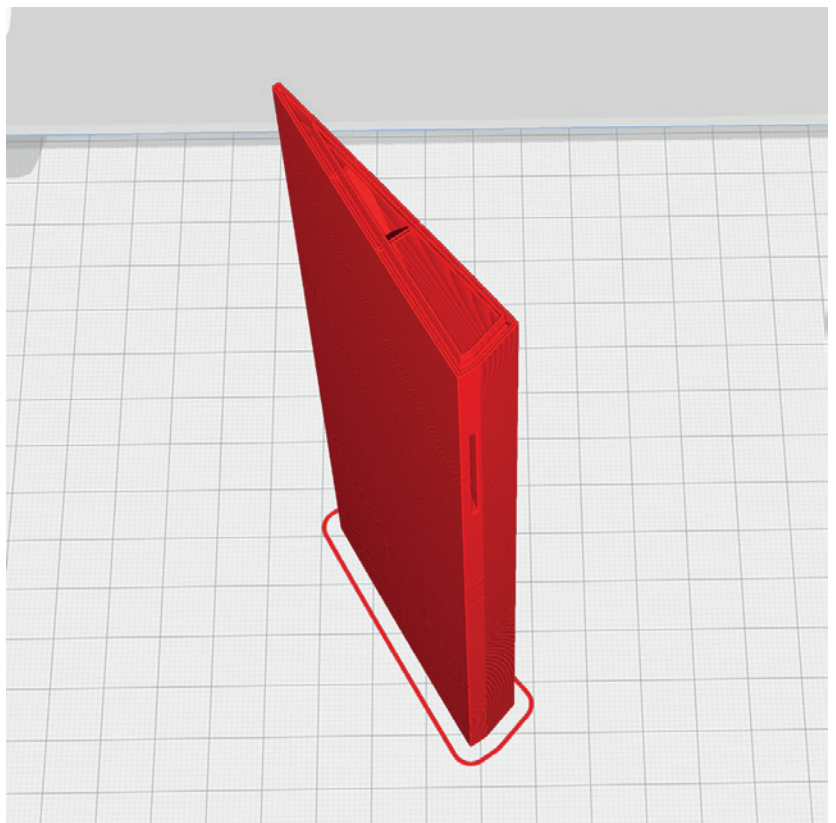

PROFILE P3_SURFACE Light-Weight LW-PLA

The following parts must be sliced with the PROFILE P3_SURFACE (1-wall-print).

Please note the additional settings for the individual parts!

PLEASE NOTE In profile P3_SURFACE, there should not be more than one STL on the buildplate at the same time, otherwise slicing errors can occur! Depending on your printer, a brim may not be required.

N_Aileron3-left/right-LW_profile3.stl

MATERIAL LW-PLA, ~ 10 g*

*Display in Cura. The actual weight is then 60% of this.

ADDITIONAL SETTINGS

- Setting Profile3_Surface
- Flow 60 % or less
- Higher nozzle temperature

The optimal weight and sufficient strength is achieved with 60 % flow. Increase the temperature until the wall thickness is 0.4 to 0.5 mm. (We print at 235° and 60% flow).



N_Canopy1-LW_profile3.stl

MATERIAL LW-PLA, ~ 29 g*

*Display in Cura. The actual weight is then 60% of this.

ADDITIONAL SETTINGS

- Setting Profile3_Surface
- Flow 60 % or less
- Higher nozzle temperature

The optimal weight and sufficient strength is achieved with 60 % flow. Increase the temperature until the wall thickness is 0.4 to 0.5 mm. (We print at 235° and 60% flow).

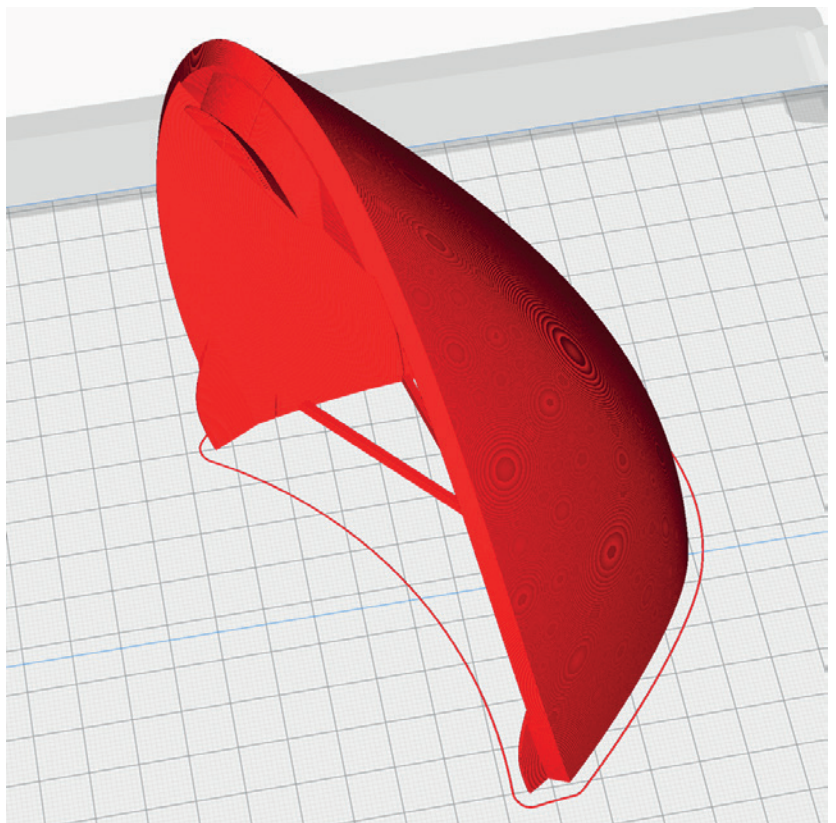

PROFILE P3_SURFACE Light-Weight LW-PLA

The following parts must be sliced with the PROFILE P3_SURFACE (1-wall-print).

Please note the additional settings for the individual parts!

PLEASE NOTE In profile P3_SURFACE, there should not be more than one STL on the buildplate at the same time, otherwise slicing errors can occur! Depending on your printer, a brim may not be required.

N_Canopy2-LW_profile3.stl

MATERIAL LW-PLA, ~ 24 g*

*Display in Cura. The actual weight is then 60% of this.

ADDITIONAL SETTINGS

- Setting Profile3_Surface
- Flow 60 % or less
- Higher nozzle temperature

The optimal weight and sufficient strength is achieved with 60 % flow. Increase the temperature until the wall thickness is 0.4 to 0.5 mm. (We print at 235° and 60% flow).

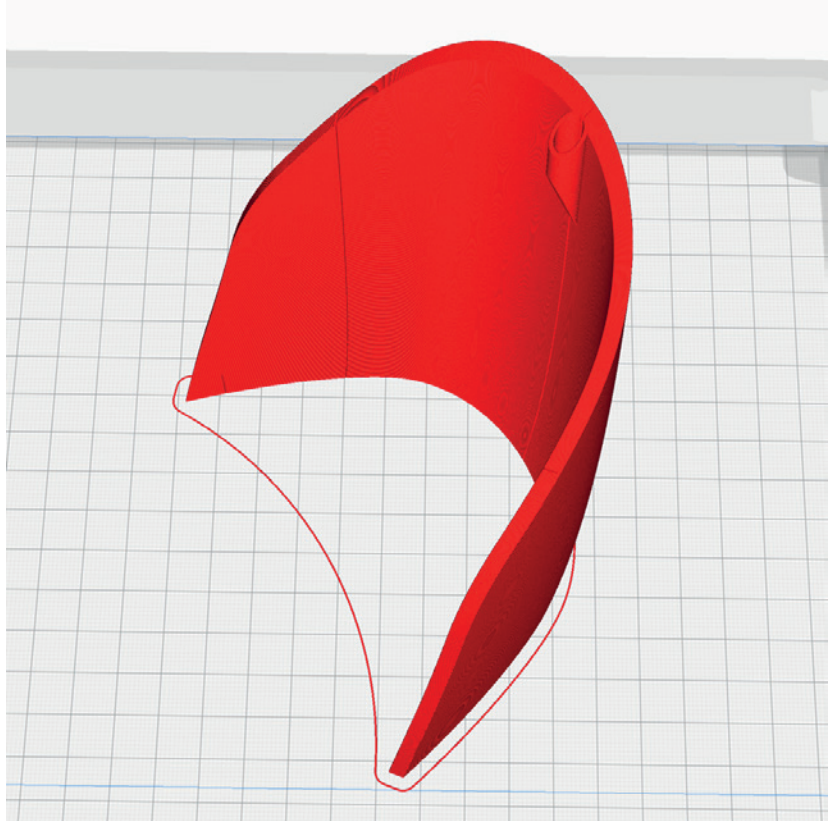

N_Elevator-left-LW_profile3.stl

MATERIAL LW-PLA, ~ 14 g*

*Display in Cura. The actual weight is then 60% of this.

ADDITIONAL SETTINGS

- Setting Profile3_Surface
- Flow 60 % or less
- Higher nozzle temperature

The optimal weight and sufficient strength is achieved with 60 % flow. Increase the temperature until the wall thickness is 0.4 to 0.5 mm. (We print at 235° and 60% flow).

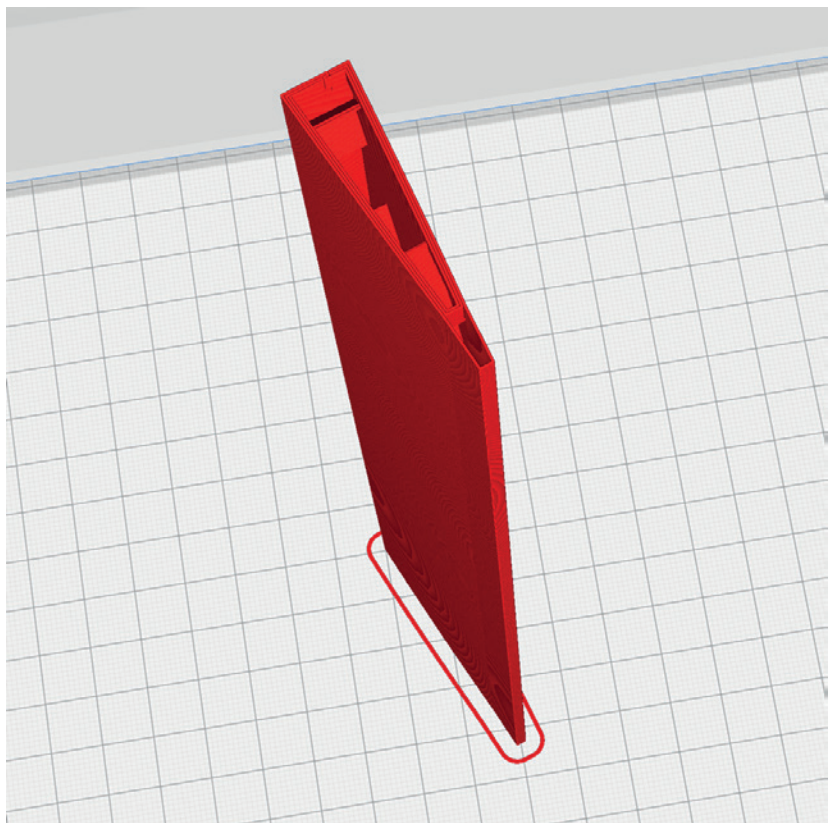

PROFILE P3_SURFACE Light-Weight LW-PLA

The following parts must be sliced with the PROFILE P3_SURFACE (1-wall-print).

Please note the additional settings for the individual parts!

PLEASE NOTE In profile P3_SURFACE, there should not be more than one STL on the buildplate at the same time, otherwise slicing errors can occur! Depending on your printer, a brim may not be required.

N_Fuselage3-LW_profile3.stl

MATERIAL LW-PLA, ~ 84 g*

*Display in Cura. The actual weight is then 60% of this.

ADDITIONAL SETTINGS

- Setting Profile3_Surface
- Flow 60 % or less
- Higher nozzle temperature

The optimal weight and sufficient strength is achieved with 60 % flow. Increase the temperature until the wall thickness is 0.4 to 0.5 mm. (We print at 235° and 60% flow).

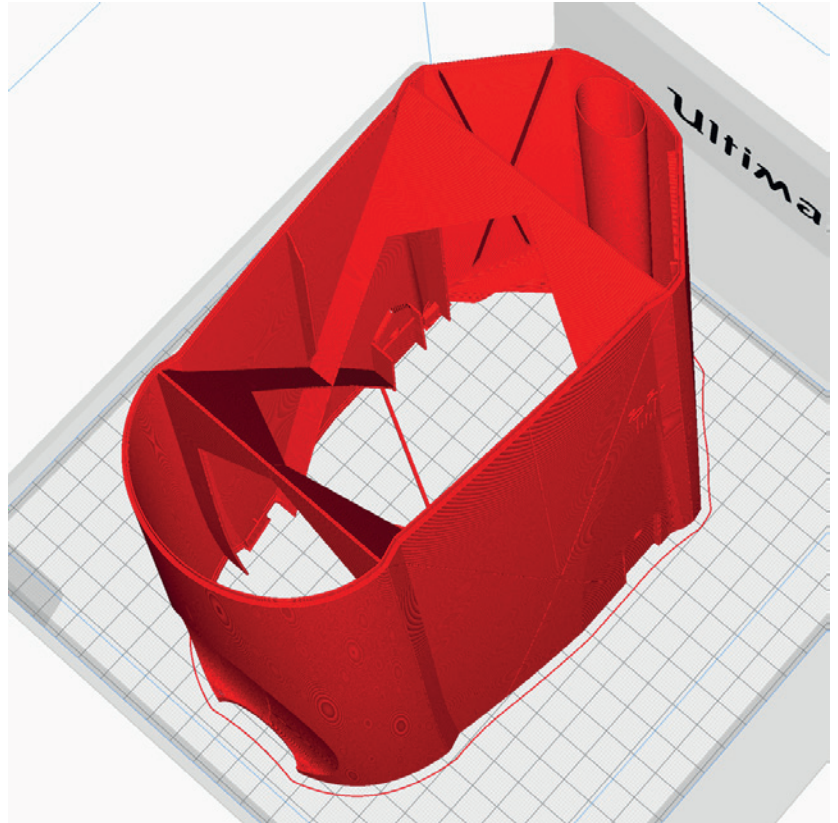

N_Fuselage4-LW_profile3.stl

MATERIAL LW-PLA, ~ 72 g*

*Display in Cura. The actual weight is then 60% of this.

ADDITIONAL SETTINGS

- Setting Profile3_Surface
- Flow 60 % or less
- Higher nozzle temperature

The optimal weight and sufficient strength is achieved with 60 % flow. Increase the temperature until the wall thickness is 0.4 to 0.5 mm. (We print at 235° and 60% flow).

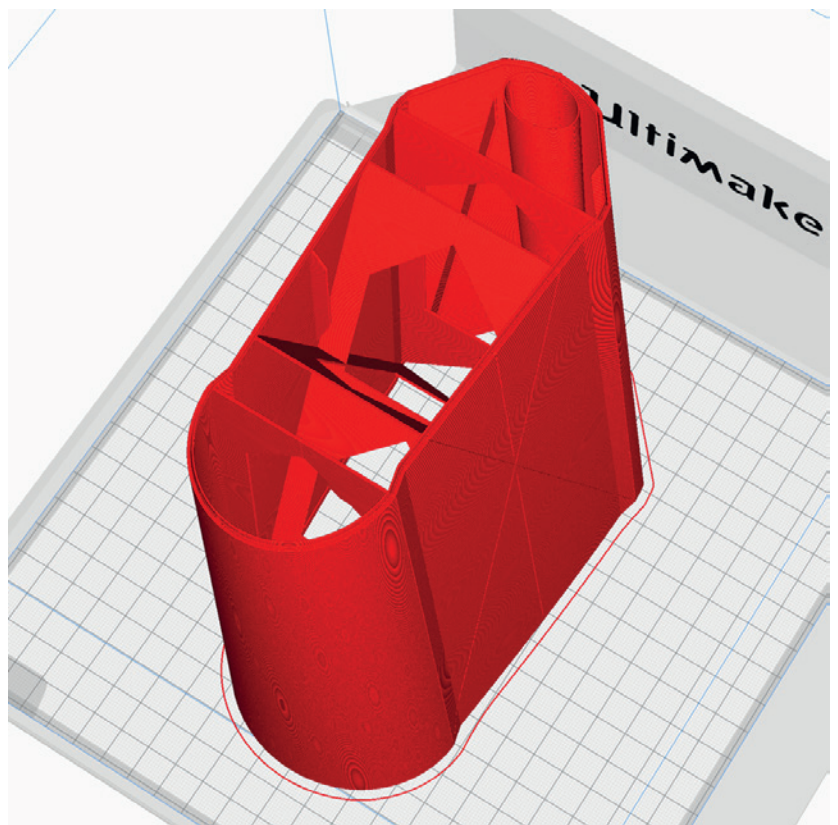

PROFILE P3_SURFACE Light-Weight LW-PLA

The following parts must be sliced with the PROFILE P3_SURFACE (1-wall-print).

Please note the additional settings for the individual parts!

PLEASE NOTE In profile P3_SURFACE, there should not be more than one STL on the buildplate at the same time, otherwise slicing errors can occur! Depending on your printer, a brim may not be required.

N_Fuselage5-LW_profile3.stl

MATERIAL LW-PLA, ~ 56 g*

*Display in Cura. The actual weight is then 60% of this.

ADDITIONAL SETTINGS

- Setting Profile3_Surface
- Flow 60 % or less
- Higher nozzle temperature

The optimal weight and sufficient strength is achieved with 60 % flow. Increase the temperature until the wall thickness is 0.4 to 0.5 mm. (We print at 235° and 60% flow).

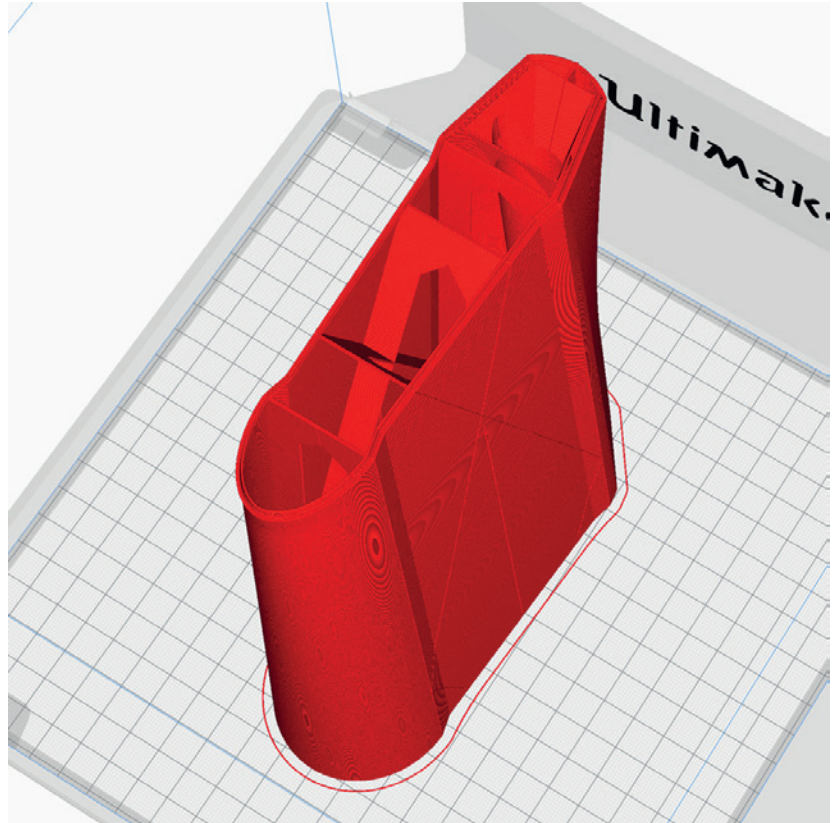

N_Fuselage6-LW_profile3.stl

MATERIAL LW-PLA, ~ 53 g*

*Display in Cura. The actual weight is then 60% of this.

ADDITIONAL SETTINGS

- Setting Profile3_Surface
- Flow 60 % or less
- Higher nozzle temperature

The optimal weight and sufficient strength is achieved with 60 % flow. Increase the temperature until the wall thickness is 0.4 to 0.5 mm. (We print at 235° and 60% flow).

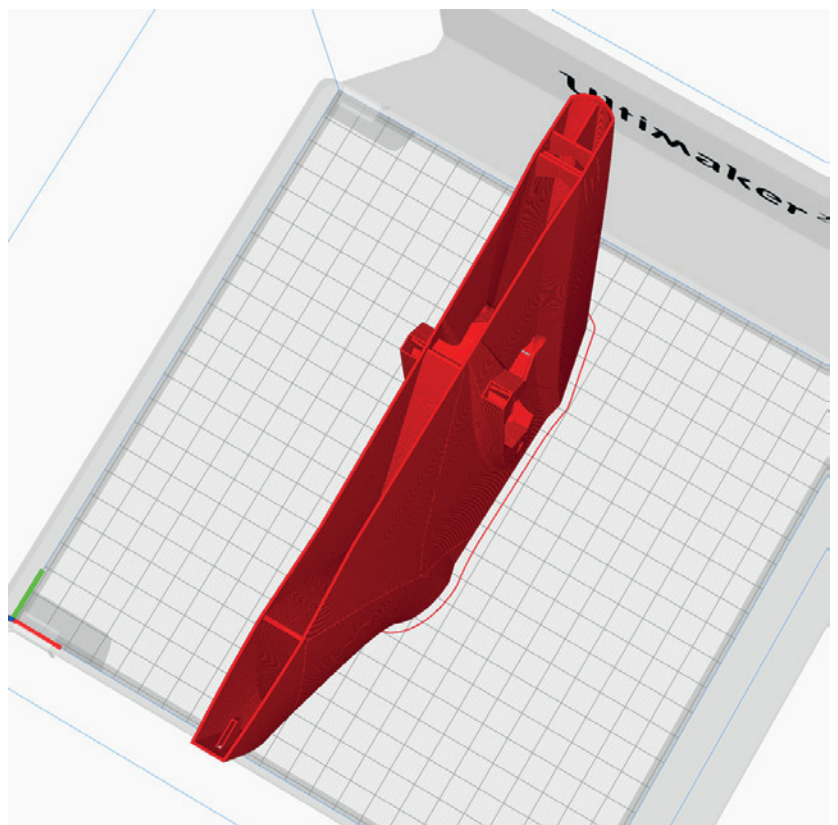

PROFILE P3_SURFACE Light-Weight LW-PLA

The following parts must be sliced with the PROFILE P3_SURFACE (1-wall-print).

Please note the additional settings for the individual parts!

PLEASE NOTE In profile P3_SURFACE, there should not be more than one STL on the buildplate at the same time, otherwise slicing errors can occur! Depending on your printer, a brim may not be required.

N_VS-LW_profile3.stl

MATERIAL LW-PLA, ~ 4 g*

*Display in Cura. The actual weight is then 60% of this.

ADDITIONAL SETTINGS

- Setting Profile3_Surface
- Flow 60 % or less
- Higher nozzle temperature

The optimal weight and sufficient strength is achieved with 60 % flow. Increase the temperature until the wall thickness is 0.4 to 0.5 mm. (We print at 235° and 60% flow).

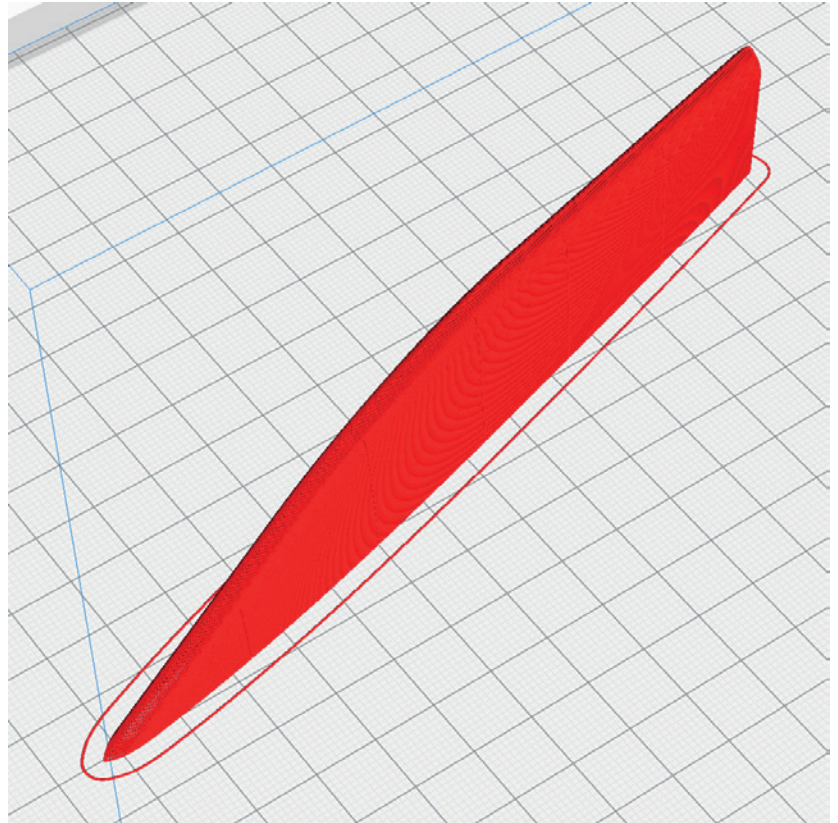

N_HS1-left/right-LW_profile3.stl

MATERIAL LW-PLA, ~ 31 g*

*Display in Cura. The actual weight is then 60% of this.

ADDITIONAL SETTINGS

- Setting Profile3_Surface
- Flow 60 % or less
- Higher nozzle temperature

The optimal weight and sufficient strength is achieved with 60 % flow. Increase the temperature until the wall thickness is 0.4 to 0.5 mm. (We print at 235° and 60% flow).

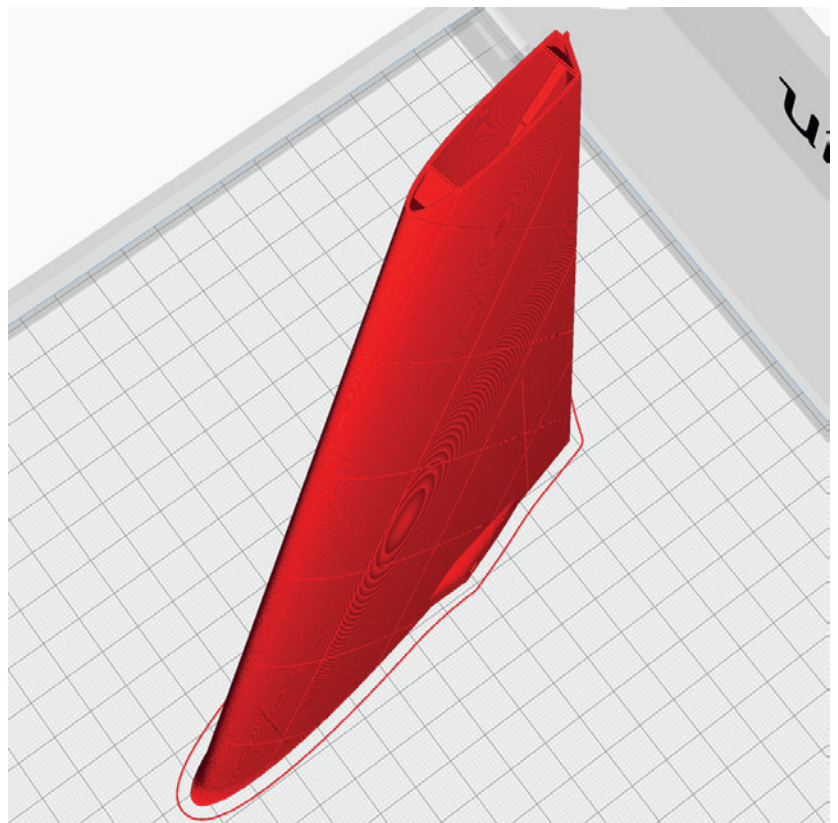

PROFILE P3_SURFACE Light-Weight LW-PLA

The following parts must be sliced with the PROFILE P3_SURFACE (1-wall-print).

Please note the additional settings for the individual parts!

PLEASE NOTE In profile P3_SURFACE, there should not be more than one STL on the buildplate at the same time, otherwise slicing errors can occur! Depending on your printer, a brim may not be required.

N_HS2-left/right-LW_profile3.stl

MATERIAL LW-PLA, ~ 4 g*

*Display in Cura. The actual weight is then 60% of this.

ADDITIONAL SETTINGS

- Setting Profile3_Surface
- Flow 60 % or less
- Higher nozzle temperature

The optimal weight and sufficient strength is achieved with 60 % flow. Increase the temperature until the wall thickness is 0.4 to 0.5 mm. (We print at 235° and 60% flow).

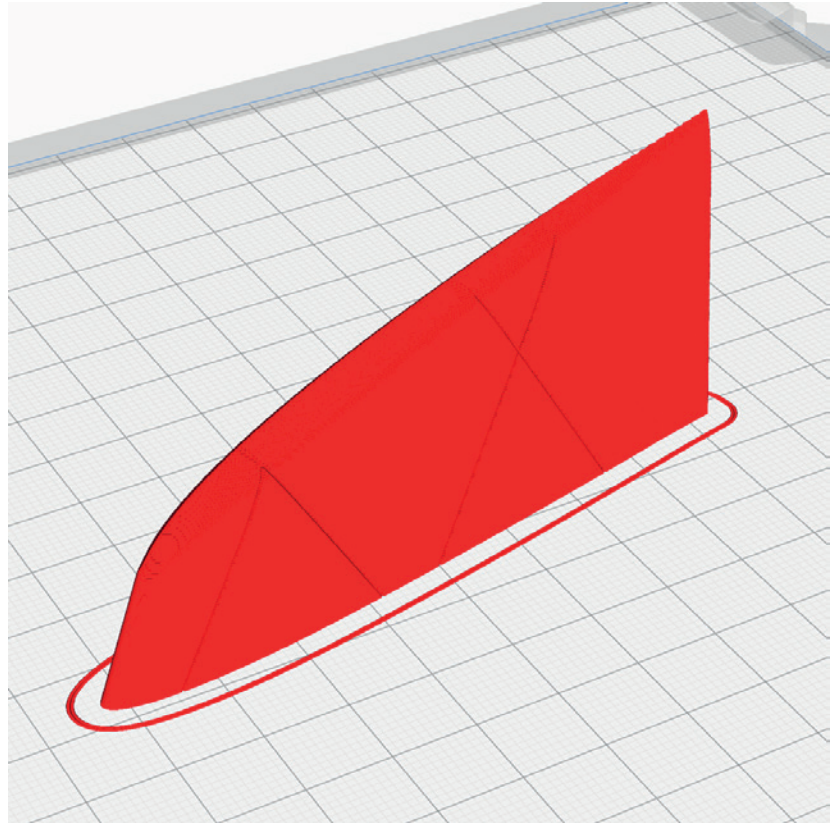

N_Rudder-LW_profile3.stl

MATERIAL LW-PLA, ~ 23 g*

*Display in Cura. The actual weight is then 60% of this.

ADDITIONAL SETTINGS

- Setting Profile3_Surface
- Flow 60 % or less
- Higher nozzle temperature

The optimal weight and sufficient strength is achieved with 60 % flow. Increase the temperature until the wall thickness is 0.4 to 0.5 mm. (We print at 235° and 60% flow).

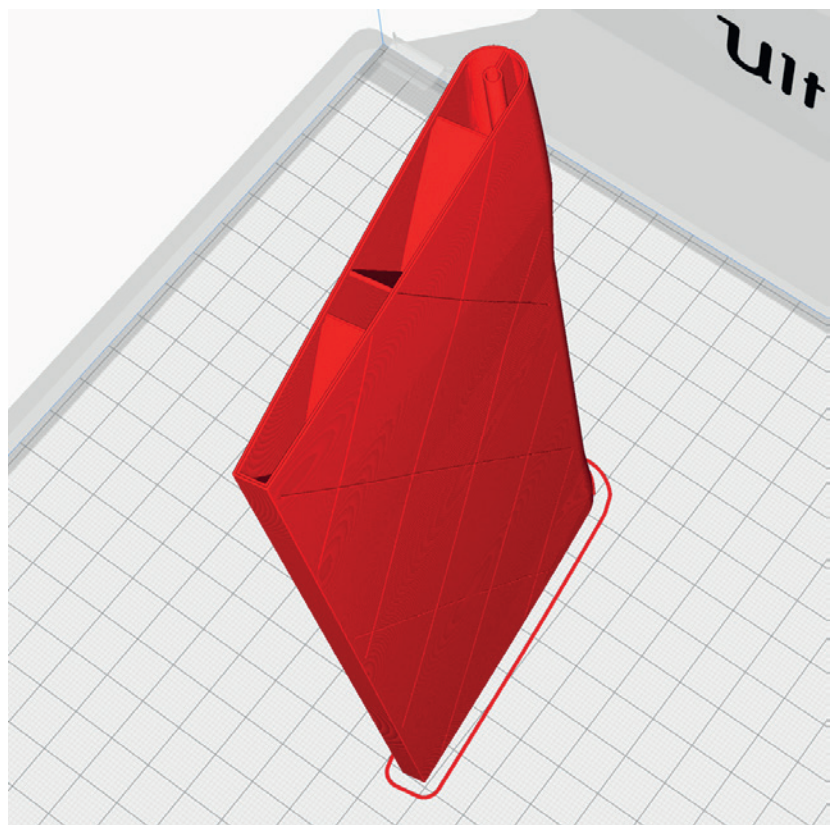

PROFILE P3_SURFACE Light-Weight LW-PLA

The following parts must be sliced with the PROFILE P3_SURFACE (1-wall-print).

Please note the additional settings for the individual parts!

PLEASE NOTE In profile P3_SURFACE, there should not be more than one STL on the buildplate at the same time, otherwise slicing errors can occur! Depending on your printer, a brim may not be required.

N_Gear2-left/right-LW_profile3.stl

MATERIAL LW-PLA, ~ 8 g*

*Display in Cura. The actual weight is then 60% of this.

ADDITIONAL SETTINGS

- Setting Profile3_Surface
- Flow 60 % or less
- Higher nozzle temperature

- Brim

The optimal weight and sufficient strength is achieved with 60 % flow. Increase the temperature until the wall thickness is 0.4 to 0.5 mm. (We print at 235° and 60% flow).

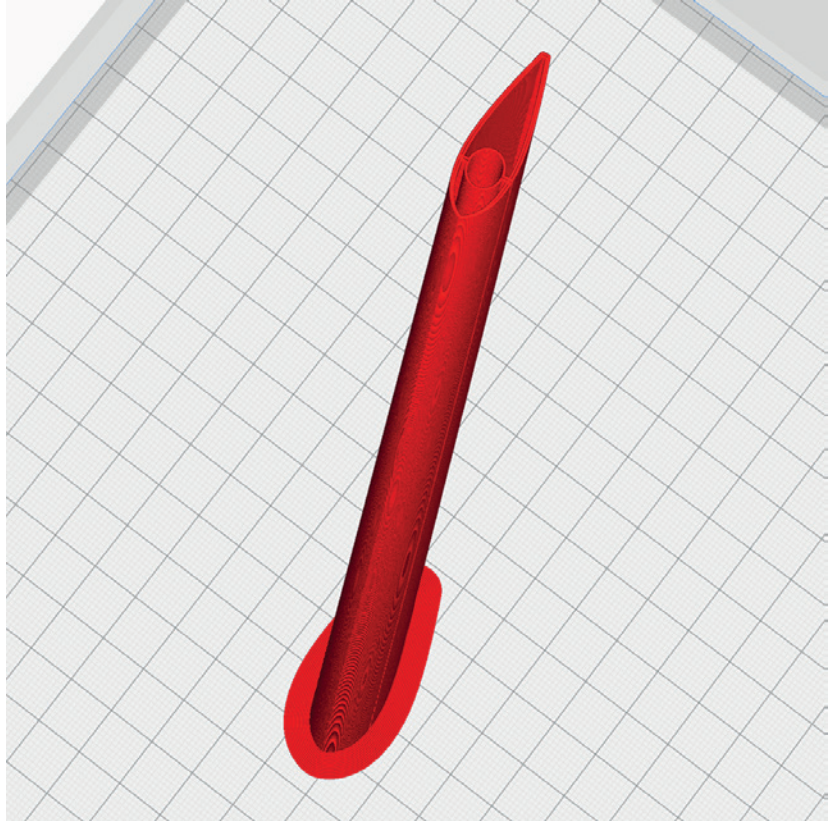

N_Topwing-left/right-LW_profile3.stl

MATERIAL LW-PLA, ~ 20 g*

*Display in Cura. The actual weight is then 60% of this.

ADDITIONAL SETTINGS

- Setting Profile3_Surface
- Flow 60 % or less
- Higher nozzle temperature

The optimal weight and sufficient strength is achieved with 60 % flow. Increase the temperature until the wall thickness is 0.4 to 0.5 mm. (We print at 235° and 60% flow).



PROFILE P3_SURFACE Light-Weight LW-PLA

The following parts must be sliced with the PROFILE P3_SURFACE (1-wall-print).

Please note the additional settings for the individual parts!

PLEASE NOTE In profile P3_SURFACE, there should not be more than one STL on the buildplate at the same time, otherwise slicing errors can occur! Depending on your printer, a brim may not be required.

N_Wing2-left/right-LW_profile3.stl

MATERIAL LW-PLA, ~ 82 g*

*Display in Cura. The actual weight is then 60% of this.

ADDITIONAL SETTINGS

- Setting Profile3_Surface
- Flow 60 % or less
- Higher nozzle temperature

Wing2 left: • Z Seam Position right

Wing2 right: • Z Seam Position left

The optimal weight and sufficient strength is achieved with 60 % flow. Increase the temperature until the wall thickness is 0.4 to 0.5 mm. (We print at 235° and 60% flow).

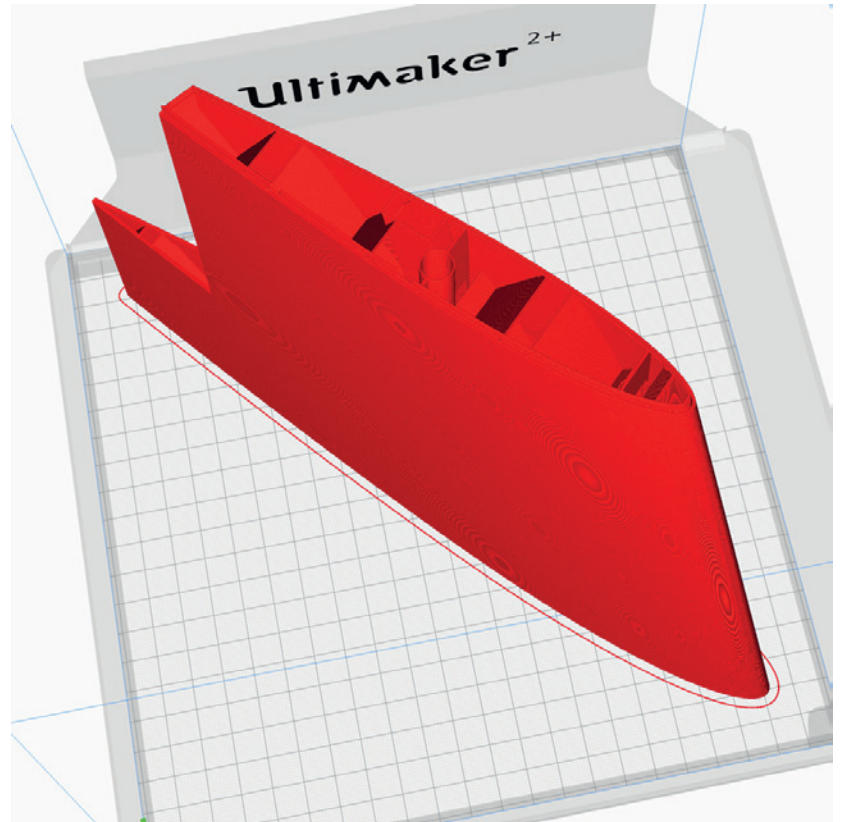

N_Wing3-left/right-LW_profile3.stl

MATERIAL LW-PLA, ~ 51 g*

*Display in Cura. The actual weight is then 60% of this.

ADDITIONAL SETTINGS

- Setting Profile3_Surface
- Flow 60 % or less
- Higher nozzle temperature

The optimal weight and sufficient strength is achieved with 60 % flow. Increase the temperature until the wall thickness is 0.4 to 0.5 mm. (We print at 235° and 60% flow).

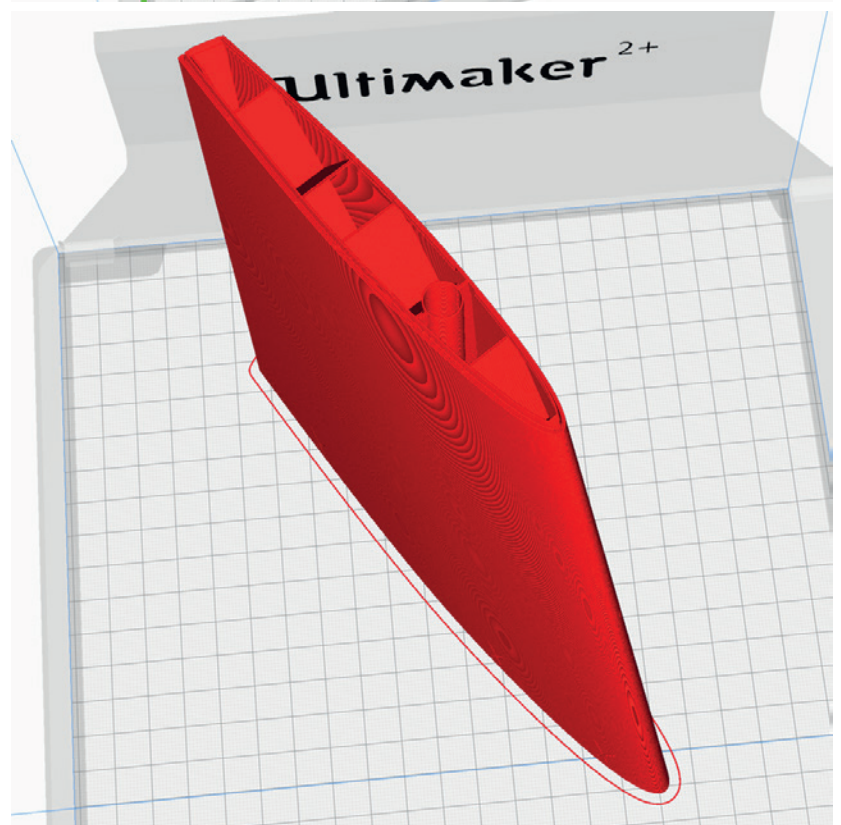

PROFILE P3_SURFACE Light-Weight LW-PLA

The following parts must be sliced with the PROFILE P3_SURFACE (1-wall-print).

Please note the additional settings for the individual parts!

PLEASE NOTE In profile P3_SURFACE, there should not be more than one STL on the buildplate at the same time, otherwise slicing errors can occur! Depending on your printer, a brim may not be required.

N_Wing4-left/right-LW_profile3.stl

MATERIAL LW-PLA, ~ 26 g*

*Display in Cura. The actual weight is then 60% of this.

ADDITIONAL SETTINGS

- Setting Profile3_Surface
- Flow 60 % or less
- Higher nozzle temperature

The optimal weight and sufficient strength is achieved with 60 % flow. Increase the temperature until the wall thickness is 0.4 to 0.5 mm. (We print at 235° and 60% flow).

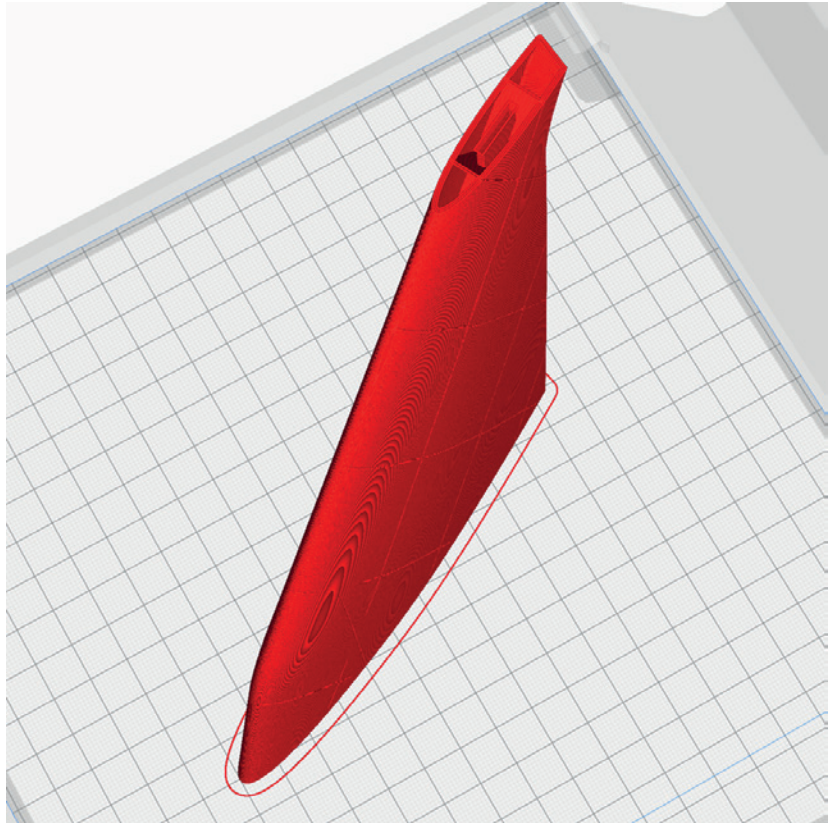

N_Winglets-LW_profile3.stl

Material: LW-PLA

It is better to print both at the same time so that the tips do not get too hot. They are also available individually in the download.

MATERIAL LW-PLA, ~ 11 g*

*Display in Cura. The actual weight is then 60% of this.

ADDITIONAL SETTINGS

- Setting Profile3_Surface
- Flow 60 % or less
- Higher nozzle temperature

The optimal weight and sufficient strength is achieved with 60 % flow. Increase the temperature until the wall thickness is 0.4 to 0.5 mm. (We print at 235° and 60% flow).

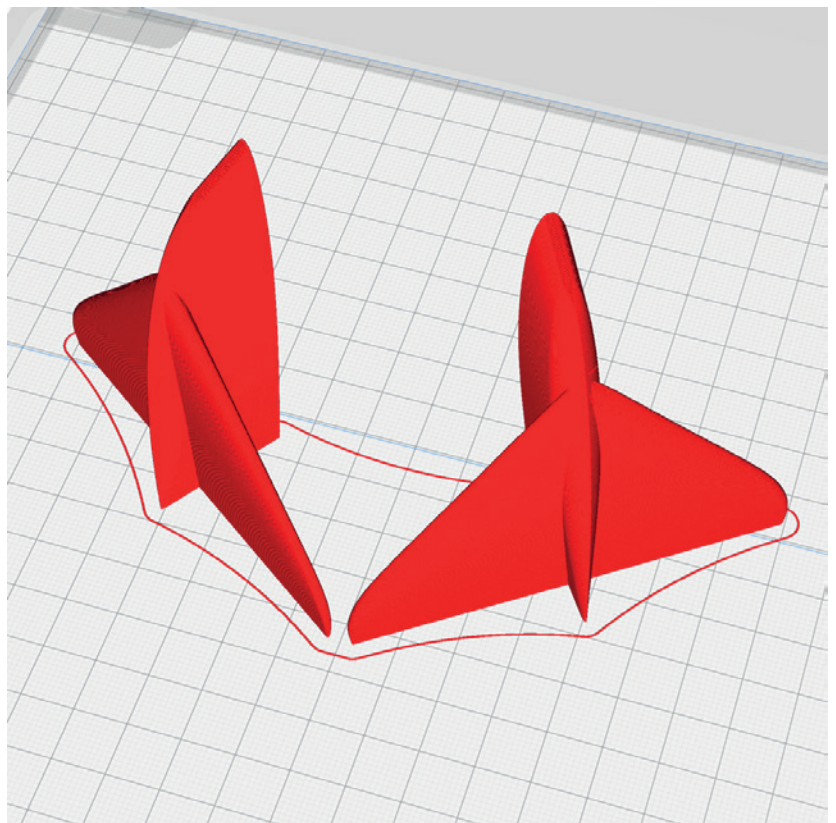

PROFILE P3_SURFACE Light-Weight LW-PLA

The following parts must be sliced with the PROFILE P3_SURFACE (1-wall-print).

Please note the additional settings for the individual parts!

PLEASE NOTE In profile P3_SURFACE, there should not be more than one STL on the buildplate at the same time, otherwise slicing errors can occur! Depending on your printer, a brim may not be required.

N_Wingtip-left/right-LW_profile3.stl

MATERIAL LW-PLA,, ~ 3 g*

*Display in Cura. The actual weight is then 60% of this.

ADDITIONAL SETTINGS

- Setting Profile3_Surface
- Flow 60 % or less
- Higher nozzle temperature

The optimal weight and sufficient strength is achieved with 60 % flow. Increase the temperature until the wall thickness is 0.4 to 0.5 mm. (We print at 235° and 60% flow).

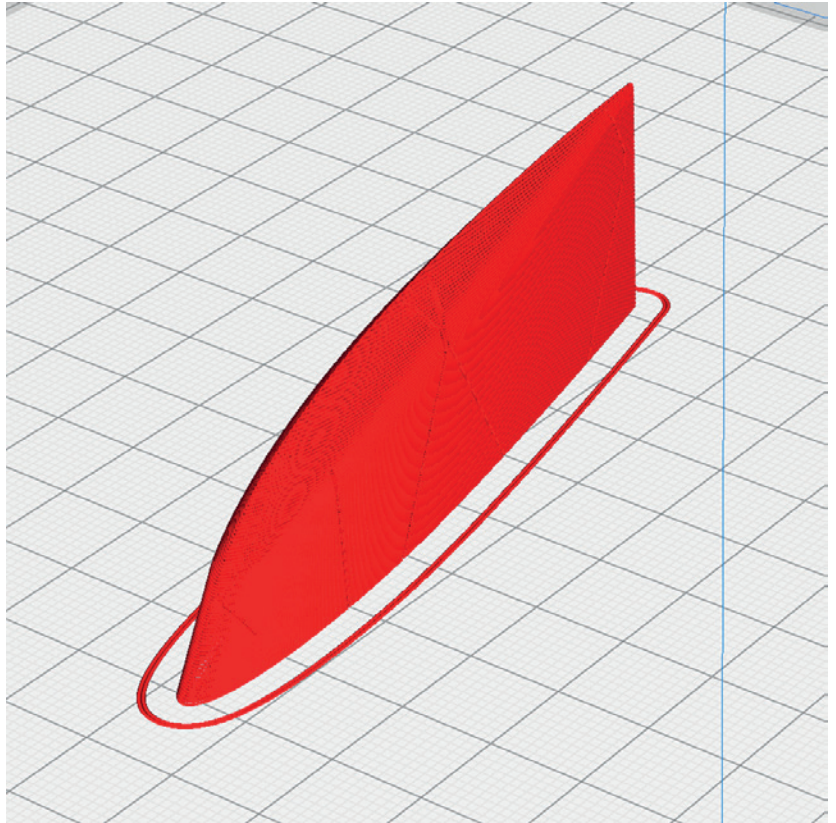

PROFILE P4_FLEX

The following parts must be sliced with the PROFILE P4_FLEX.
Please note the additional settings for the individual parts!

N_Hinges_profile4.stl

MATERIAL TPU ~ A95, Weight: ~ 2 g

ADDITIONAL SETTINGS

- Wall Line Count: 10

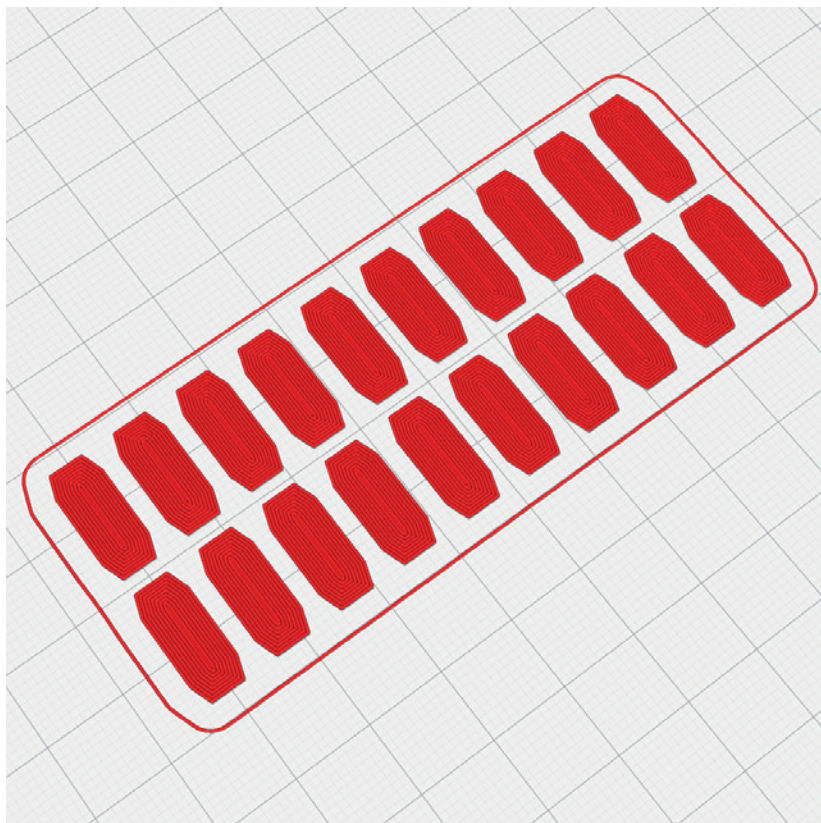

N_Wheel_profile4.stl

MATERIAL TPU ~ A95, Weight: ~ 12 g

ADDITIONAL SETTINGS

- Print twice
- Wall Line Count: 10

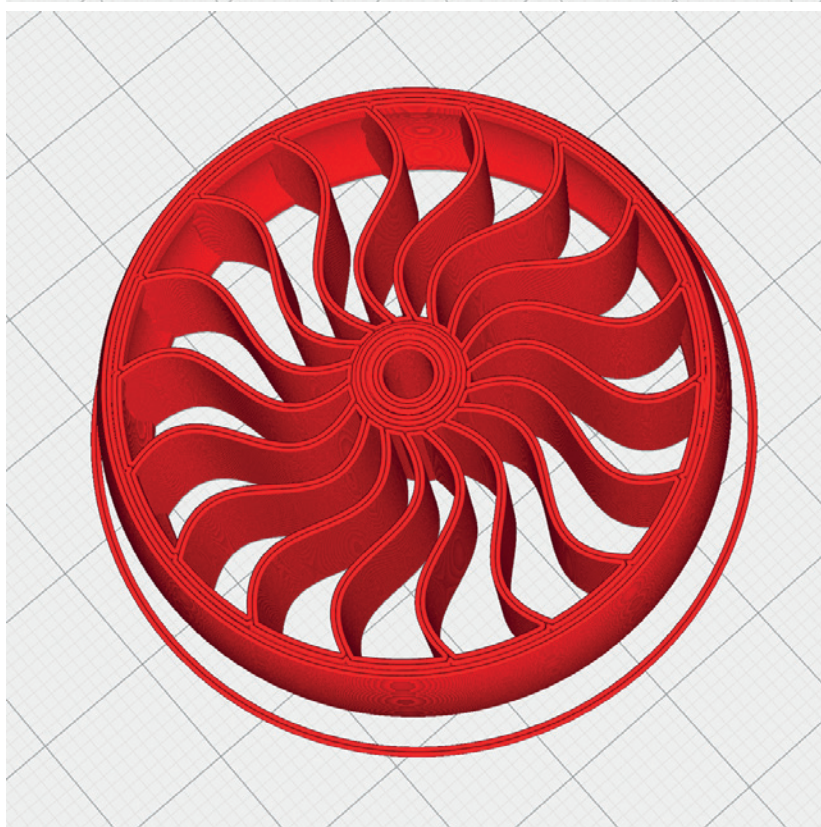

PROFILE P4_FLEX

The following parts must be sliced with the PROFILE P4_FLEX.
Please note the additional settings for the individual parts!

N_Wheel tail_profile4.stl

MATERIAL TPU ~ A95, Weight: ~ 2 g

ADDITIONAL SETTINGS

- Wall Line Count: 10

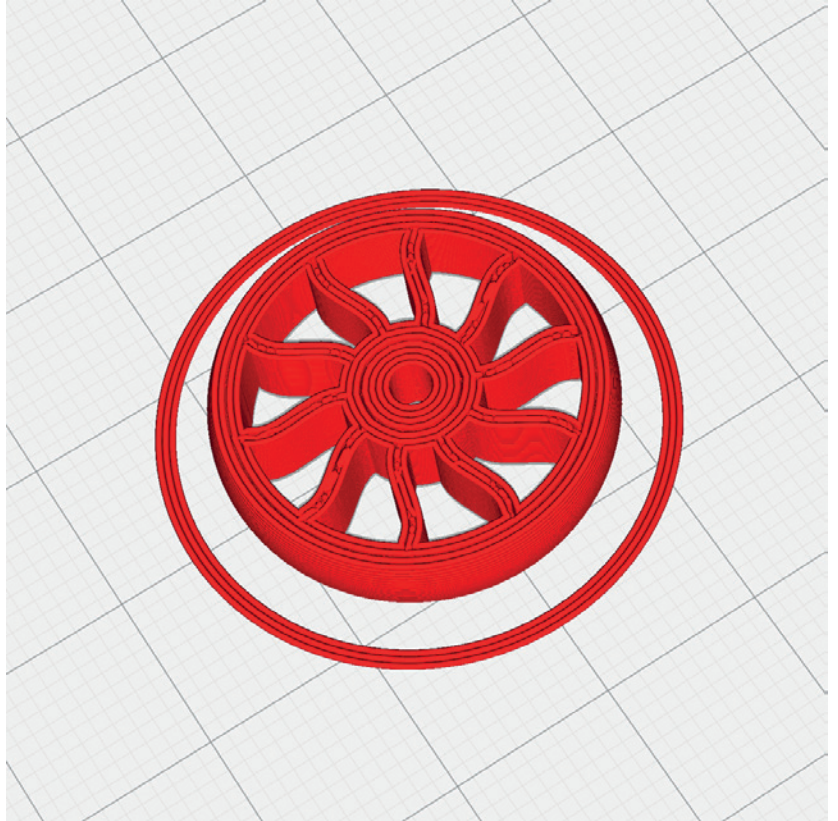

N_Tension belt_profile4.stl

MATERIAL TPU ~ A95, Weight: ~ 3 g

ADDITIONAL SETTINGS

- Wall Line Count: 10

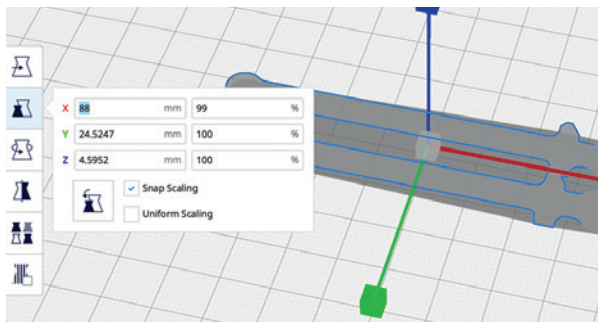

Tension belt length

In the folder Individual parts you will find the tension belts also as a single file. If you want to change them slightly in length, you can simply change the dimension of the X-axis in Cura (Uniform scaling must NOT be selected).

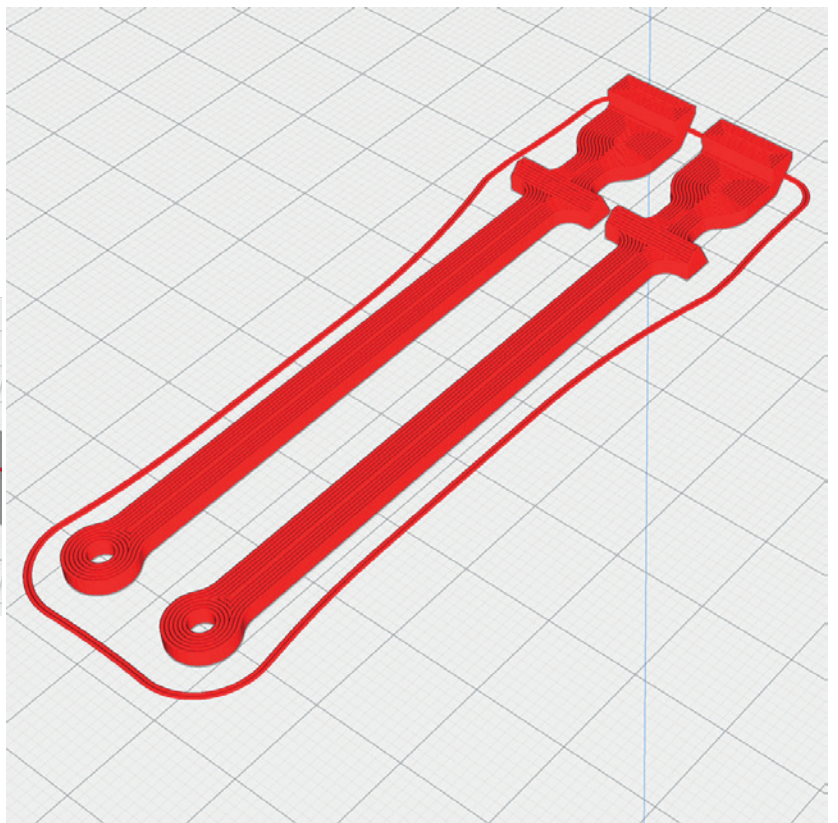

REQUIRED ACCESSOIRES

Filament

- normal PLA about 400 grams
- LW-PLA about 500 grams (**Absolutely necessary**)
- TPU (A95) about 20 grams

Materials

- some tapping screws $\text{Ø}2 \times 8$ mm
(**simply search for: M2 flat head tapping screw assortment**) →
- CA super glue (liquid and liquid medium)
- CA activator
- Servo extension cable
- Carbon tube $\text{Ø}8 \times 1000$ mm (inside 6mm), 2 pieces
- Carbon rod $\text{Ø}4 \times 1000$, 1 piece
- Carbon rod $\text{Ø}1.5 \text{mm} \times 300$, 1 piece
- Steel wire $\text{Ø}1$ mm
- Rod connection, 5 pieces
- Self adhesive velcro tape

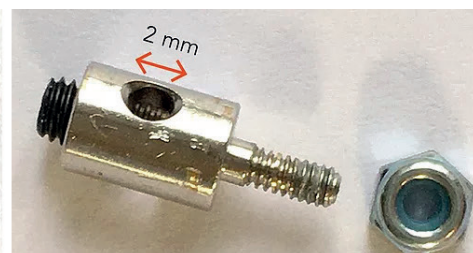

Tools

- Cutter knife
- small Philips screwdriver
- Drill $\text{Ø}4$ mm, $\text{Ø}2,5$ mm, $\text{Ø}1,5$ mm

RC Components

The Notos allows the installation of a wide variety of drives.
We have good experience with this version:

ENGINE Hacker A30-10XL or comparable motors



Pay attention to the position of the motor shaft

PROP 14x7 (3S)

BEC-CONTROLLER 80 A (must fit the engine!)

RECEIVER 6 Channel

BATTERY 3S Lipo, about 2.400-3000 MaH

SERVOS Hitec HS-5055MG or (or similar in the same size), 5 pieces

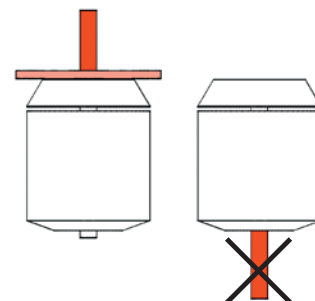

For precise aerobatics we recommend not to use cheap servos.

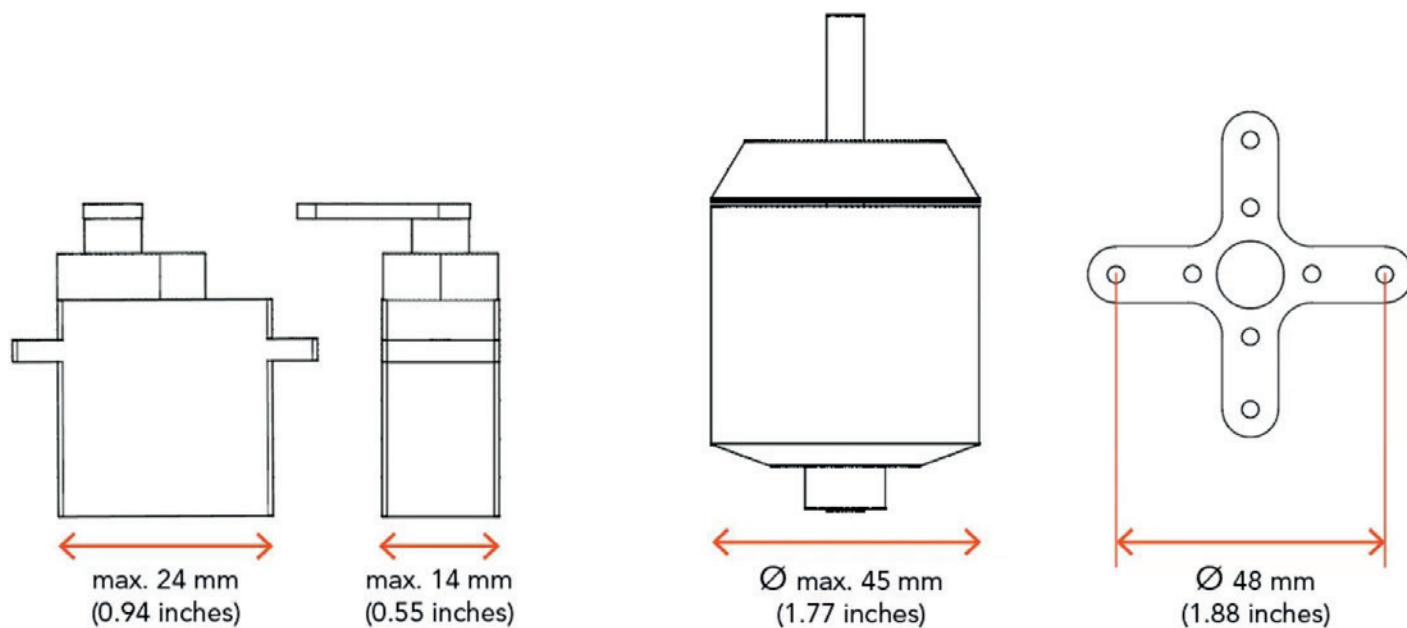

ASSEMBLING MANUAL

Basic information

Gluing the parts

To glue the fuselage and wing parts well, **use medium-liquid CA** adhesive.

First check whether the parts go well together. Then apply a lot of CA glue to the part with the connections and all surfaces that will touch later (except the bowden tubes). Put the parts together and align the parts perfectly. If glue comes out, wipe with a cloth. Then spray activator spray on the glue points.

IMPORTANT For a strong connection, the adhesive surfaces should be sanded. Please only use fresh CA glue and activator spray for curing! The adhesive connections must hold perfectly!

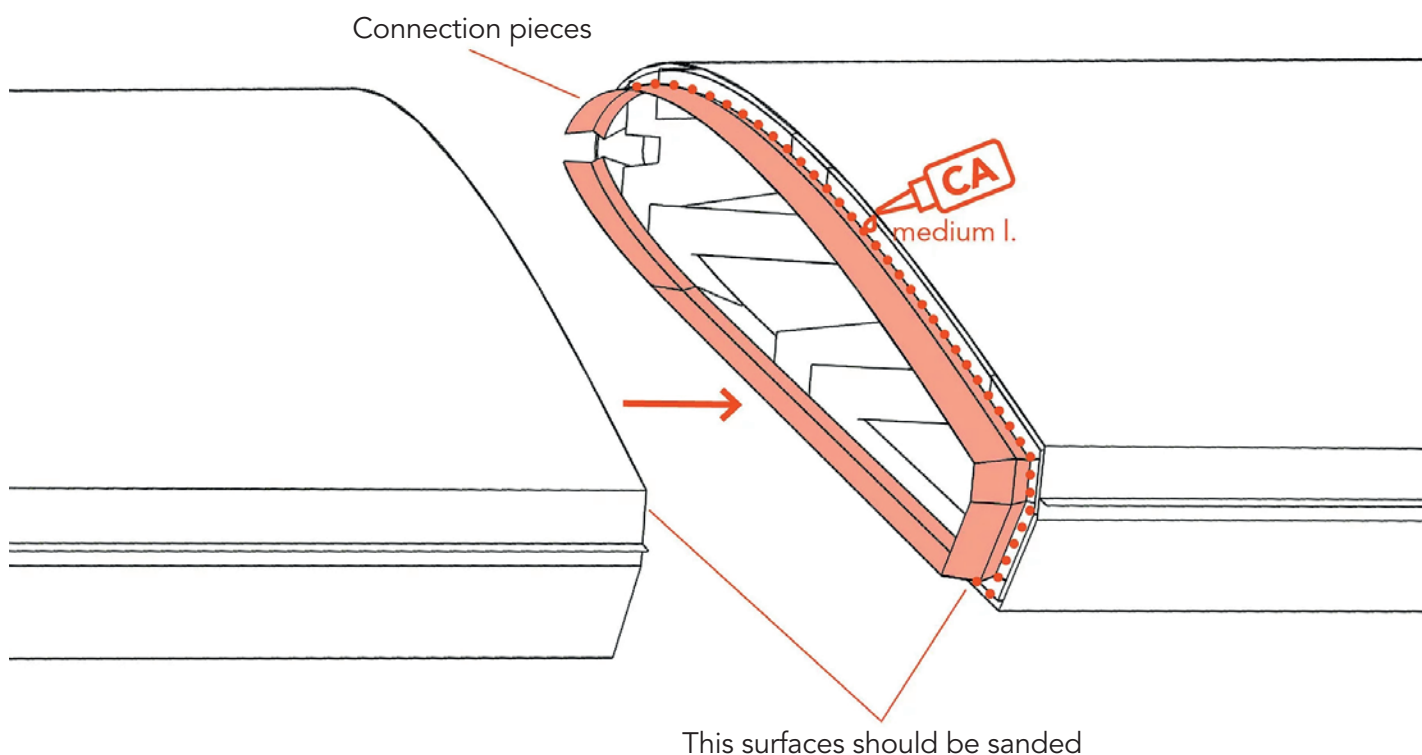

Basic information

Installation of the TPU hinges

First insert the hinge into the movable flap and add a drop of liquid CA adhesive into the gap. Wait for the glue to drain completely, then spray the activator on it.

Then put the flap in the wing until the flap touches the spacers and put a drop of CA glue on the hinge. Wait again for the glue to run in, and then spray the activator on it.

Do not use too much glue, the flap must move easily!

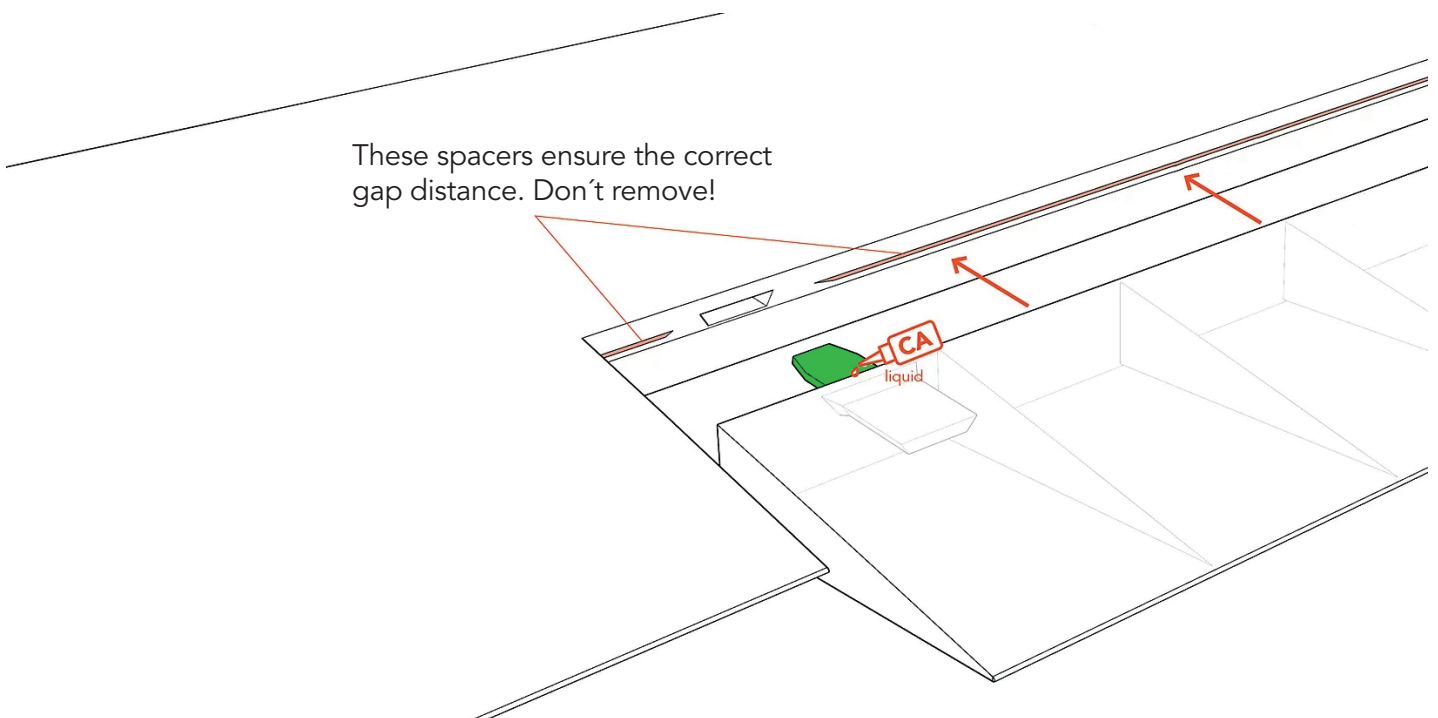

Canopy latch

Insert the slider from above into the fuselage opening and the carbon rod from the front through the opening. If it does not move easily, drill it out a little. It must be easy to move!

Push rod and slider all the way back and glue them together with a drop of CA glue.

IMPORTANT The glue must NOT get on the fuselage, harden it with activator spray!

Then clamp a small rubber band.

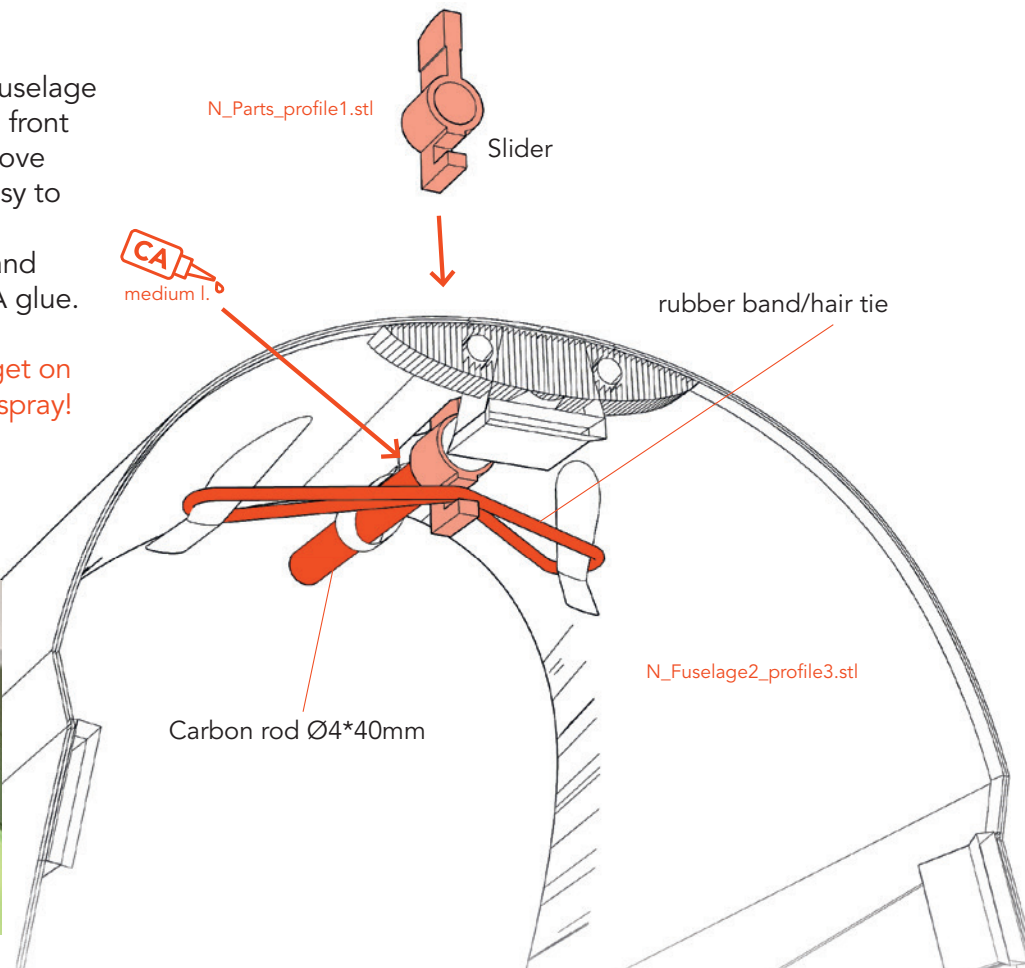
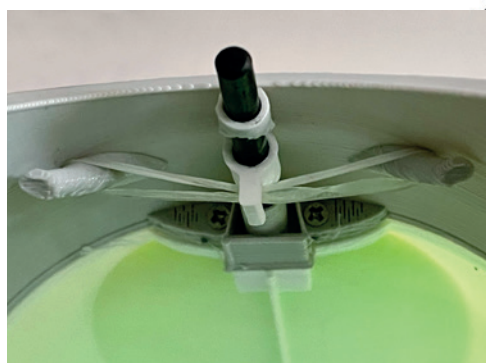

Fuselage assembly

Instructions see at basic information

Start with STEP 1: Glue the interconnects in fuselage 2. Then put enough glue on Fuselage2 (not on the interconnects) and put the parts together.

IMPORTANT First put all interconnects only a little bit into all slots and then join the parts with a quick movement, so that the glue does not set already during the pushing together.

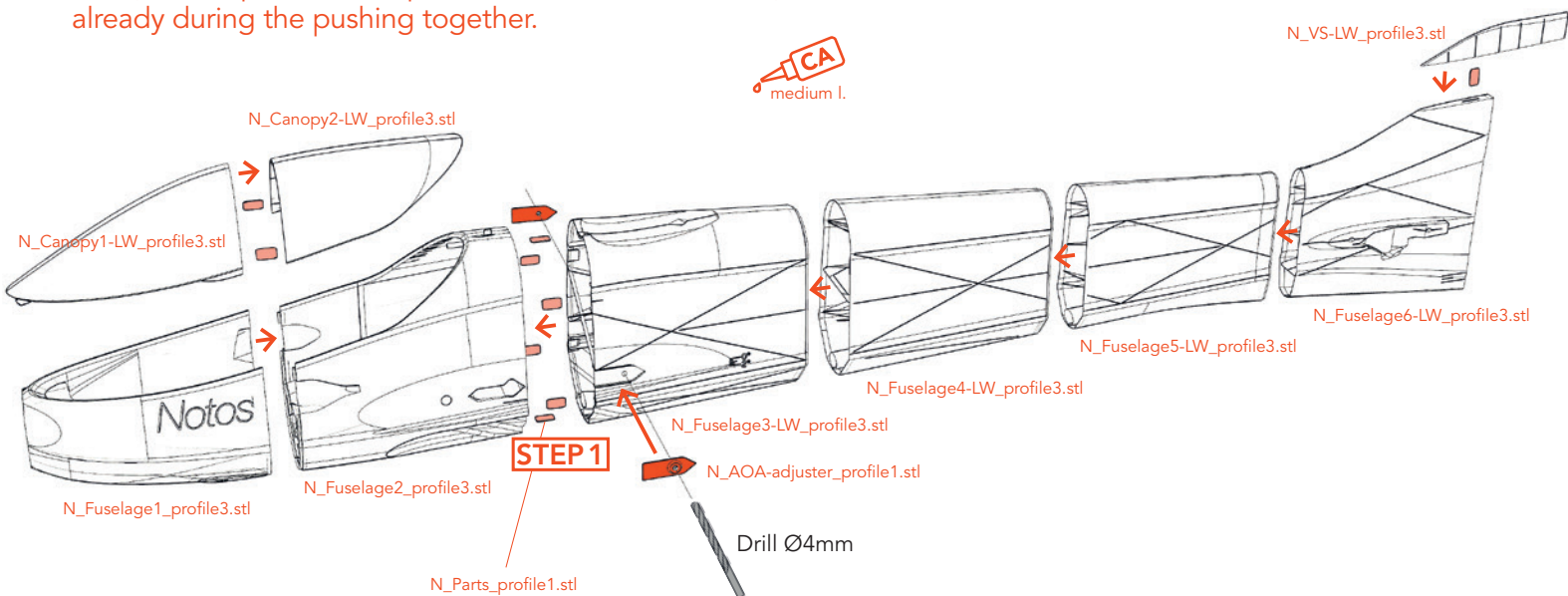

Wings assembly

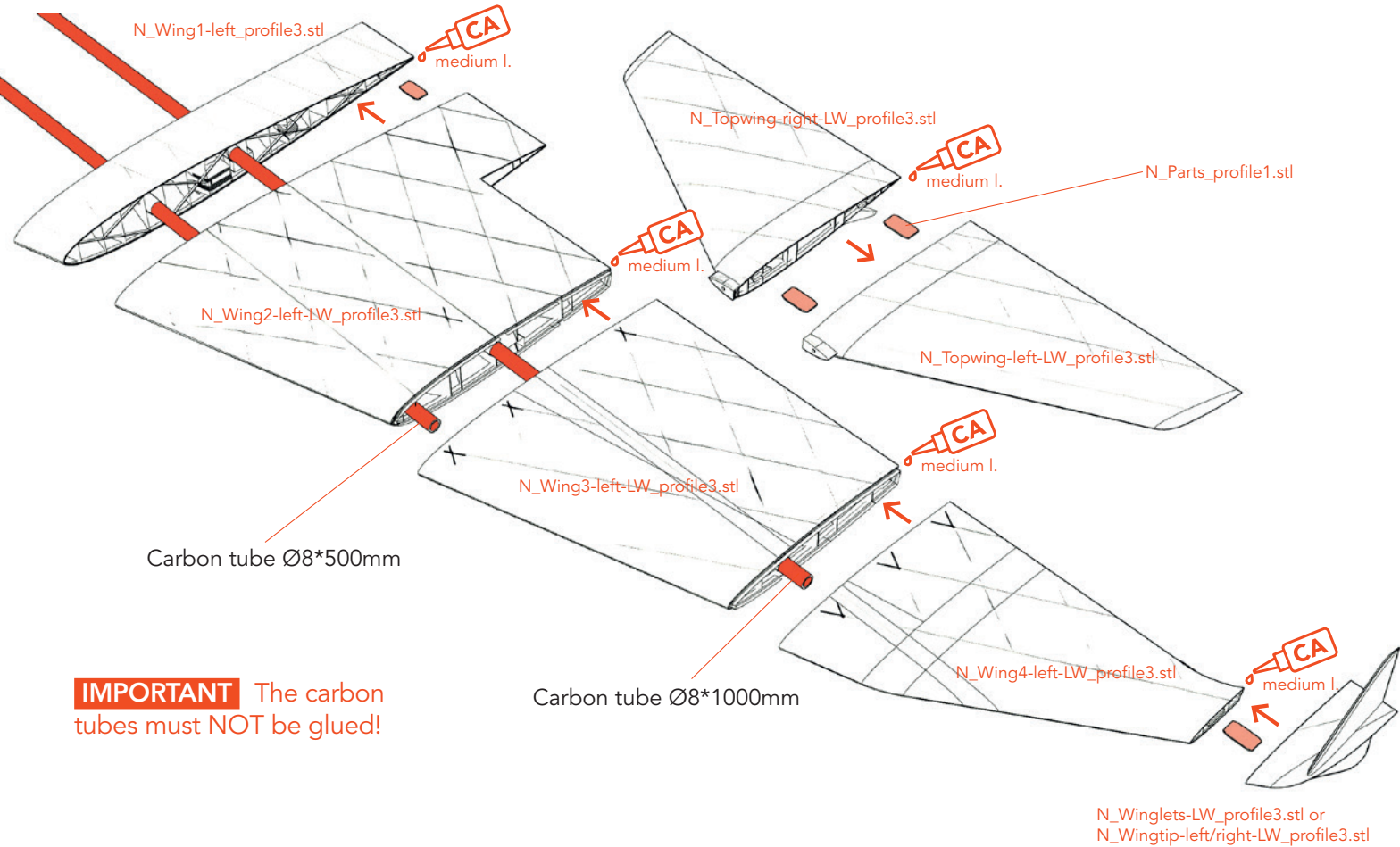

Ailerons assembly

Instructions see at basic information

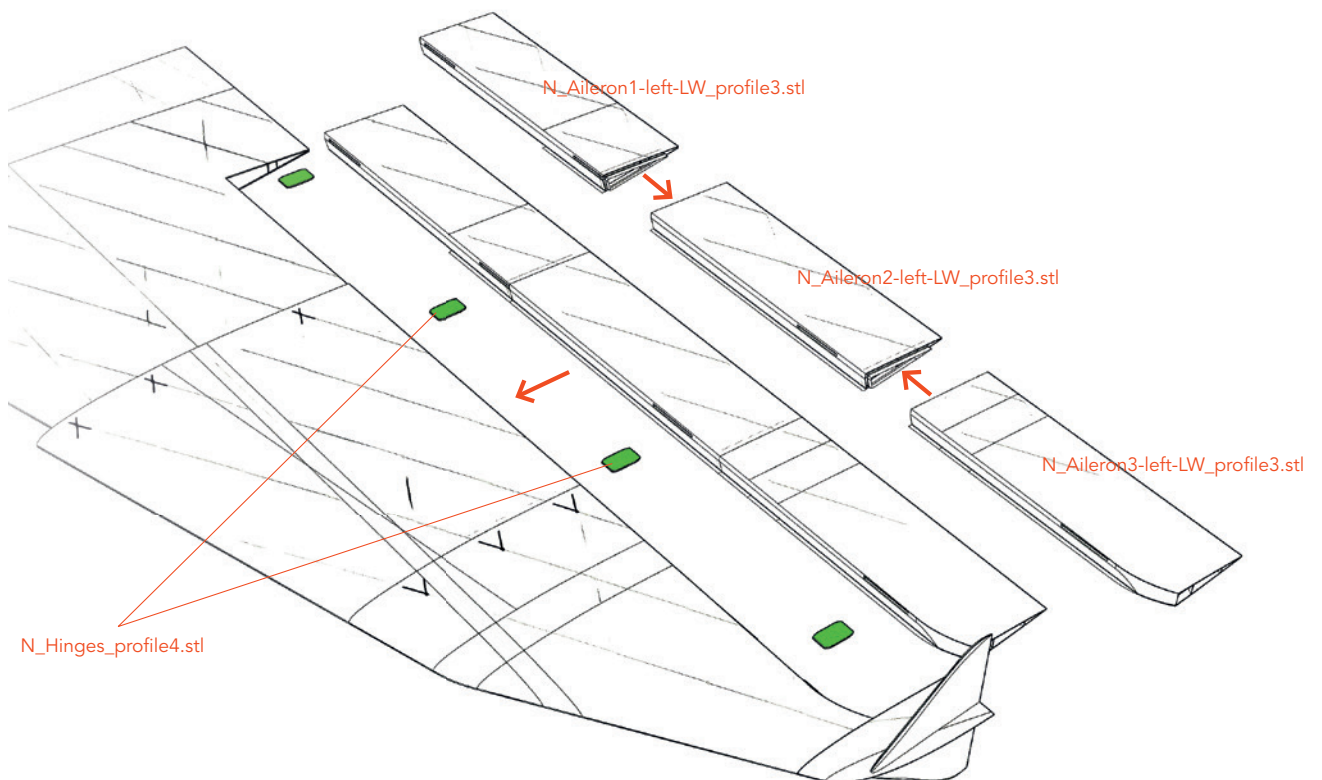

Gear assembly

Slightly sand the glued areas on the carbon tube.

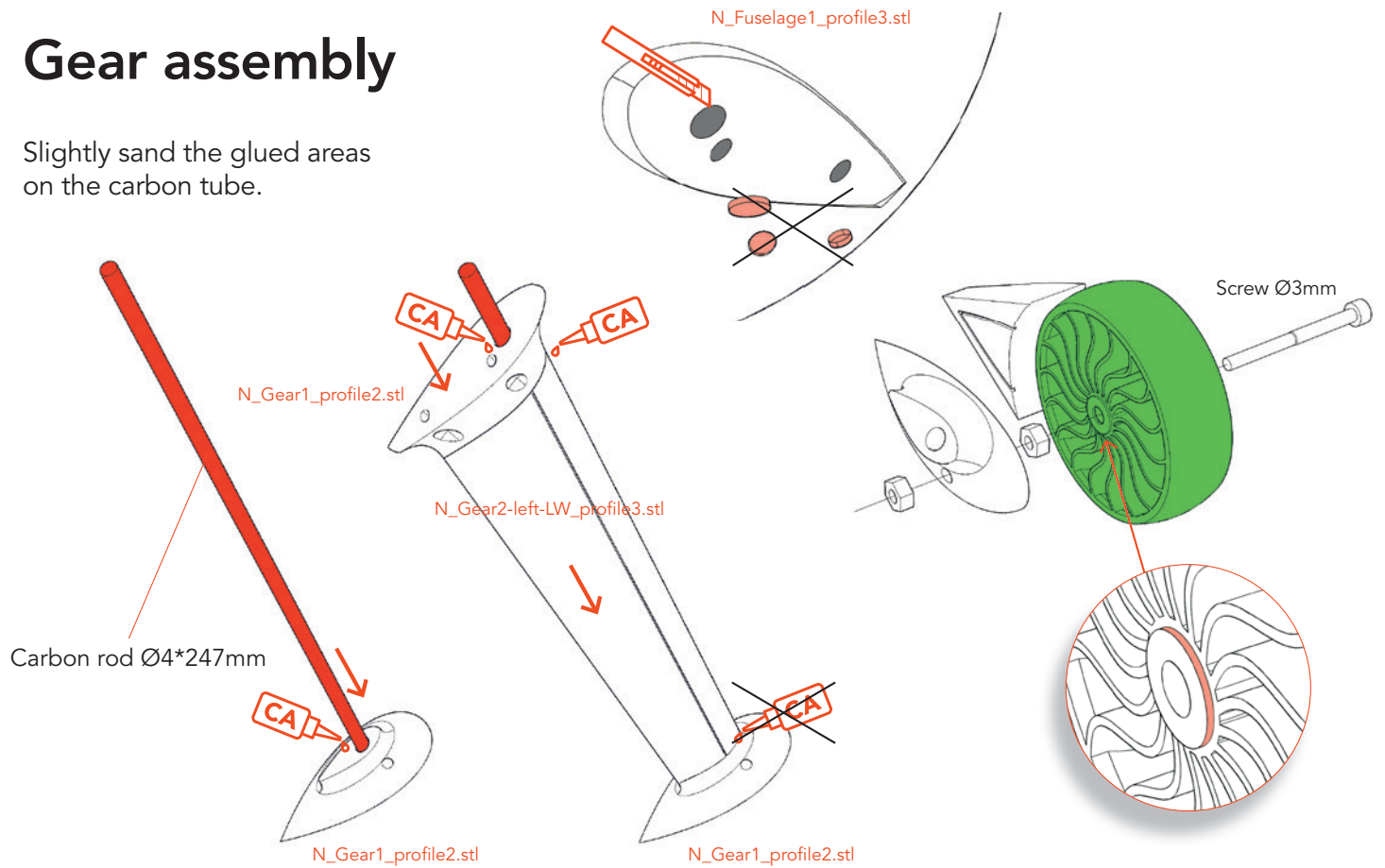

Rudder assembly

Make sure the rudder is accurate and moves easily.

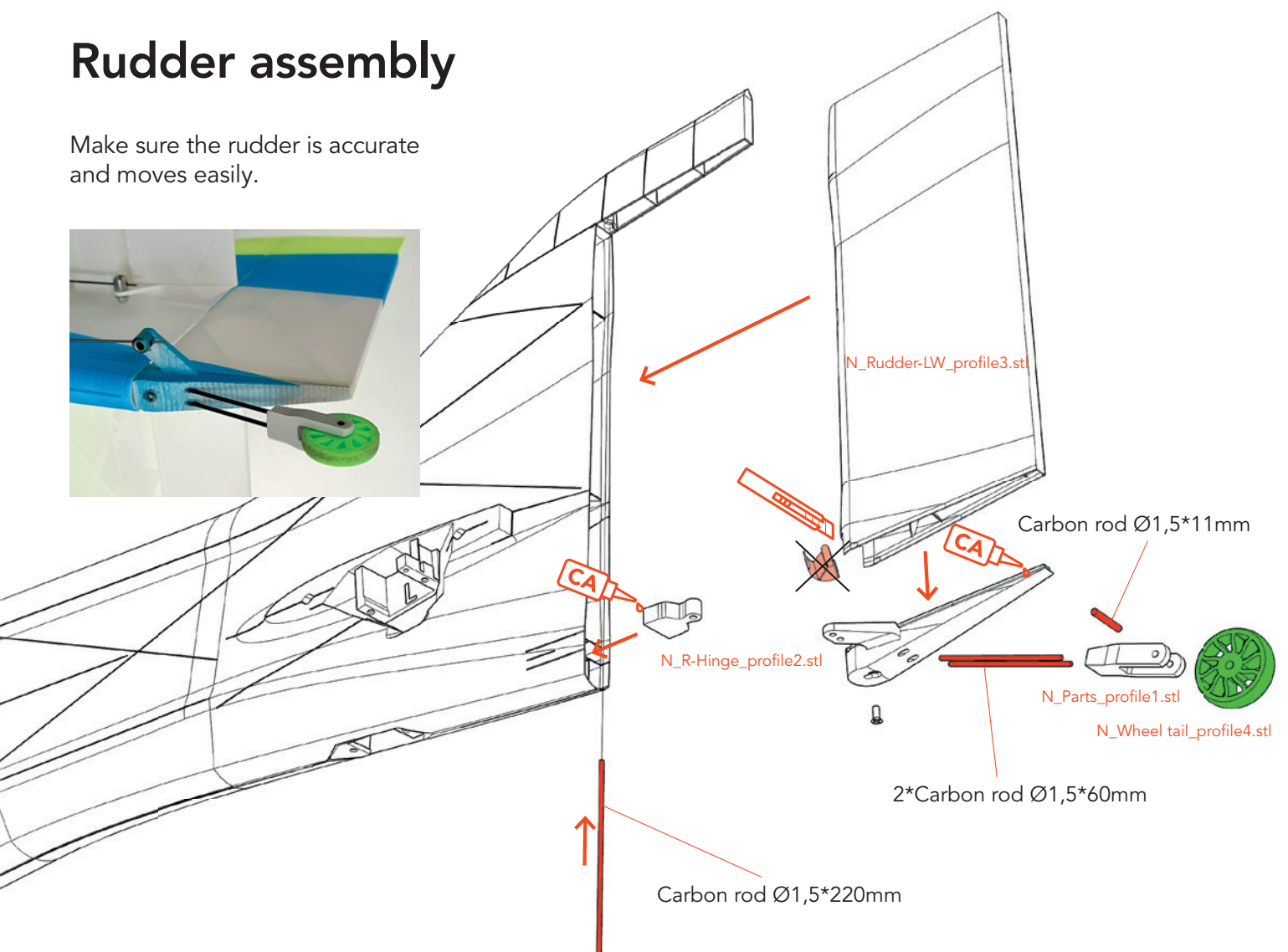

Elevator assembly

Remove the support for the servo cable holes

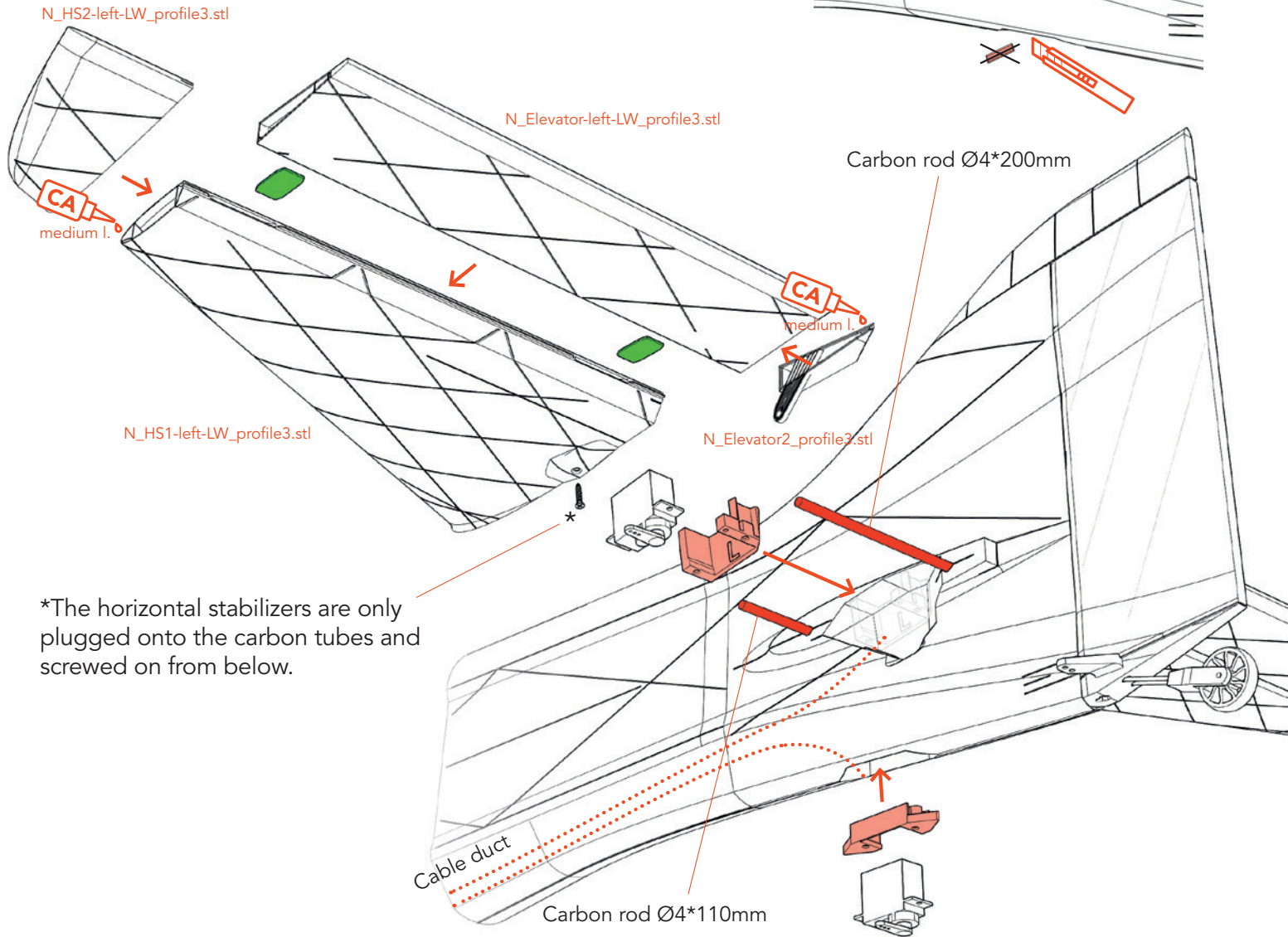
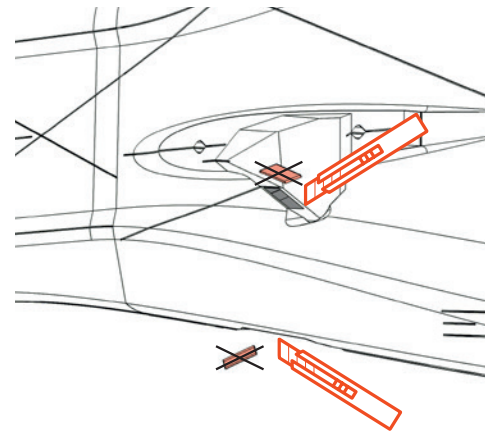

*The horizontal stabilizers are only plugged onto the carbon tubes and screwed on from below.

Top wing fastening

Place the top wing on the fuselage and tighten it from the inside with two tapping screws.

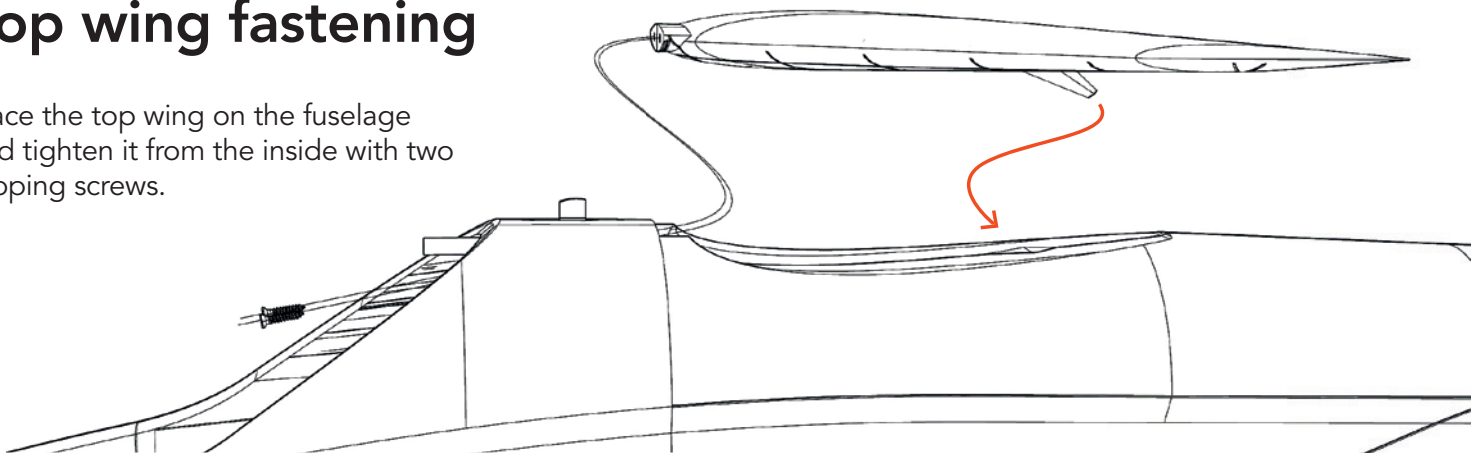

Motor mounting

SAFETY FIRST Use appropriate screws for motor mounting to ensure safe operation! Make sure the prop runs smoothly and does not generate vibrations. **Check regularly that the motor mounting is absolutely tight!**

Before you glue the motor bracket into the fuselage, test fit the motor to make sure everything fits exactly.

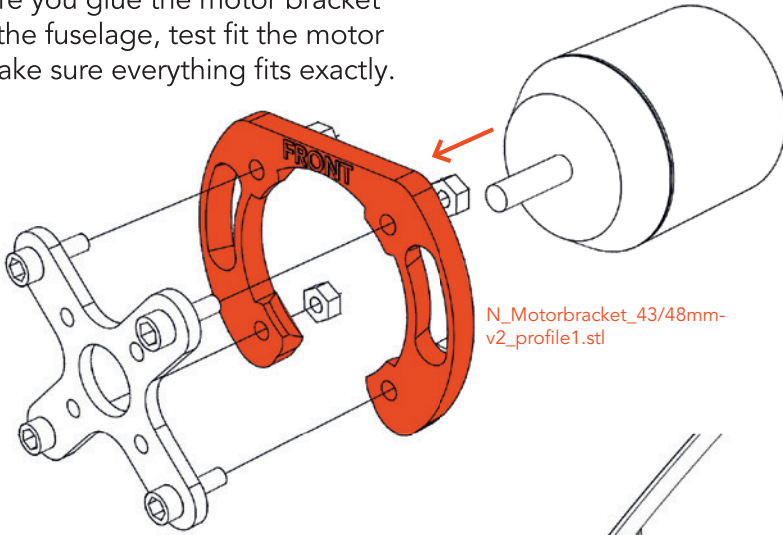

The motor points 1.5 degrees to the right. You can change the angle of the motor by placing shims.

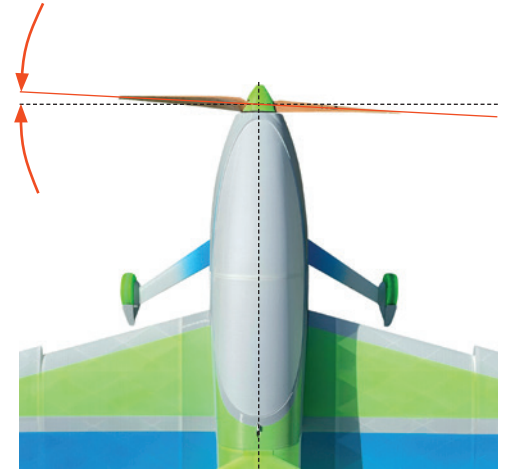

Slide the motor mount all the way forward into the fuselage and tape it down very well. The motor must not come loose under the stress of aerobatic maneuvers!

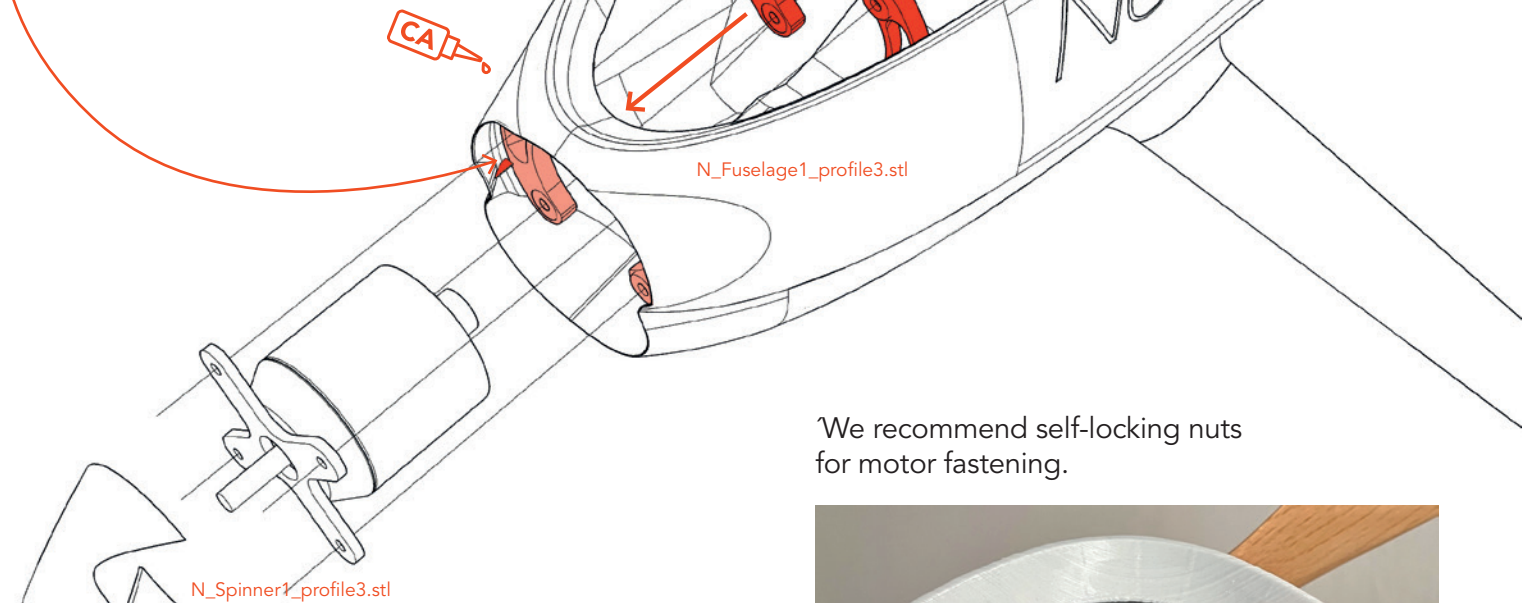

We recommend self-locking nuts for motor fastening.

Spinner 1

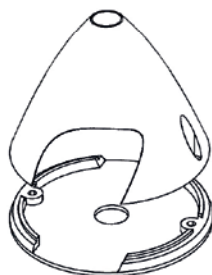

Spinner 2

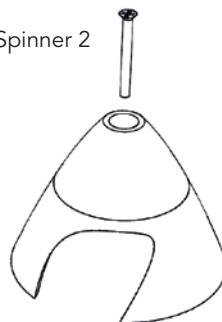

Wing fastening

Screw the TPU tensioners into the wings, attach the wings to the fuselage and clip the tensioners into the frame.

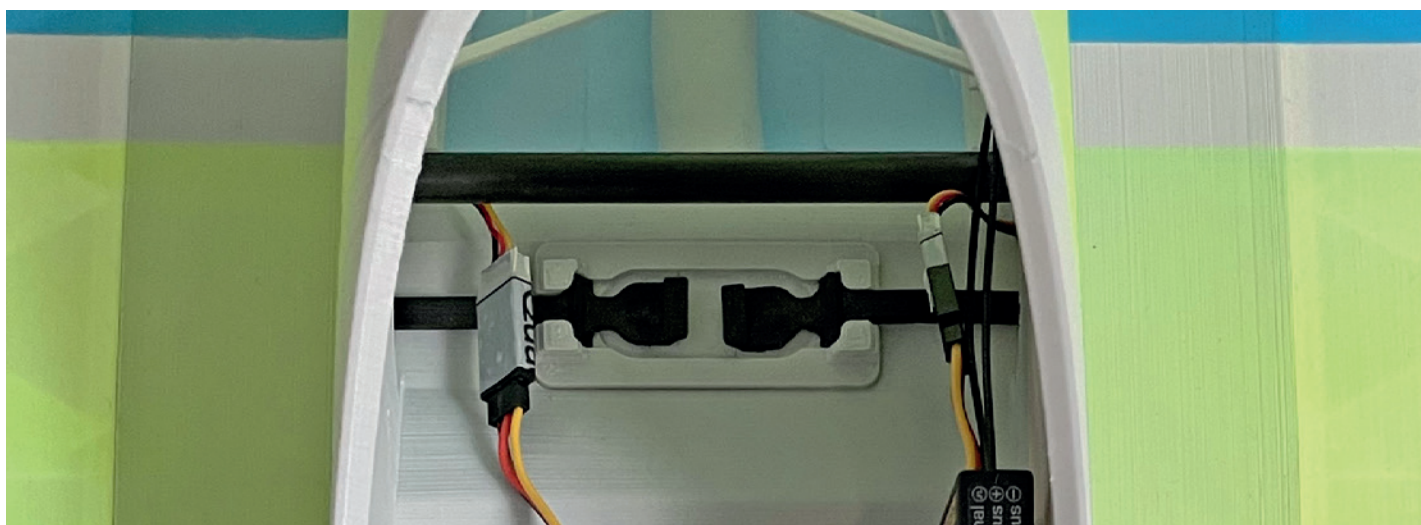
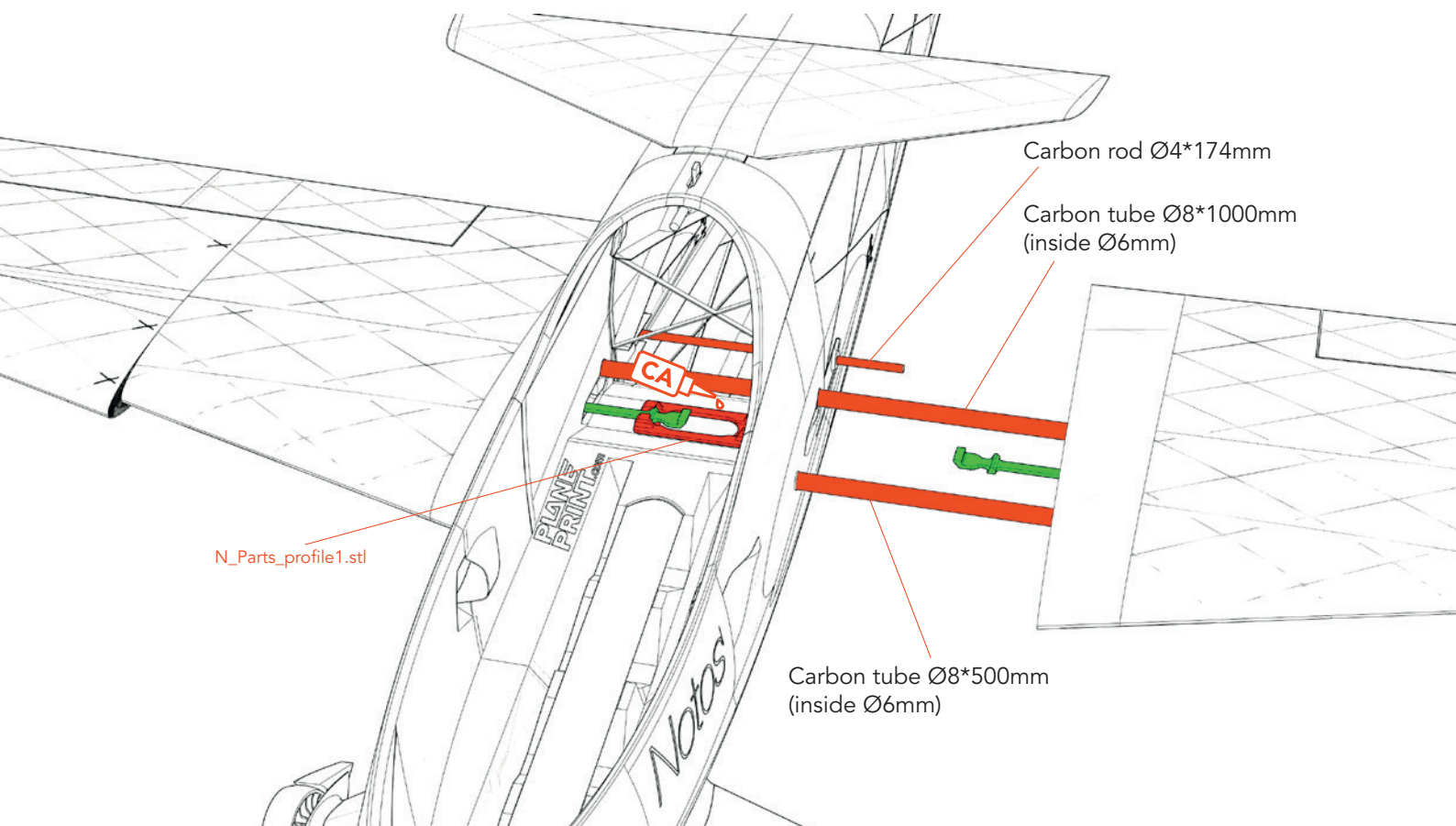
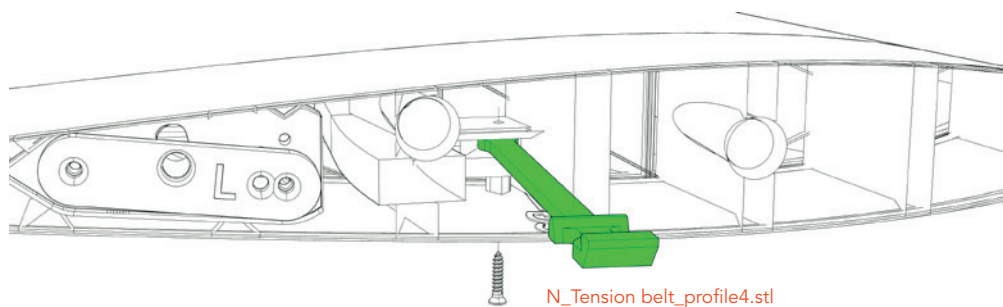

AOA (Angle of attack) adjustment

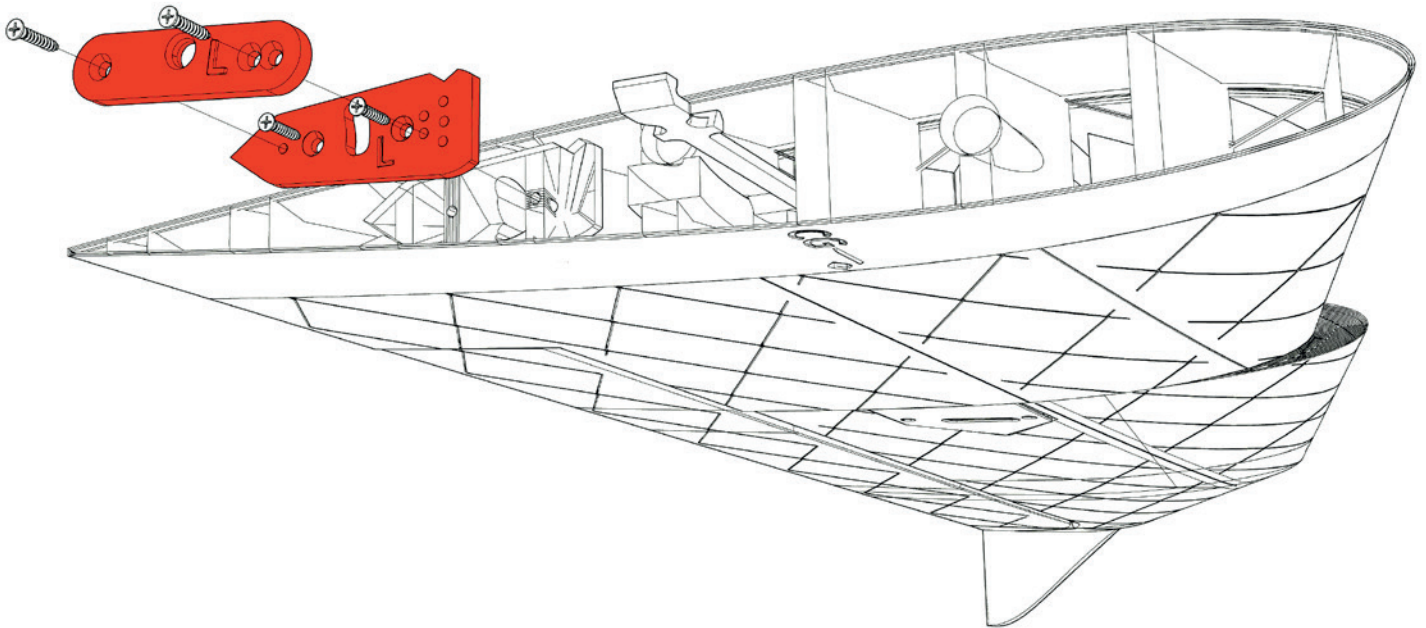

With a hole mask on the wing, the AOA can be adjusted quickly and easily:

BASIC SETTING We recommend 0.5 degrees as the basic setting.

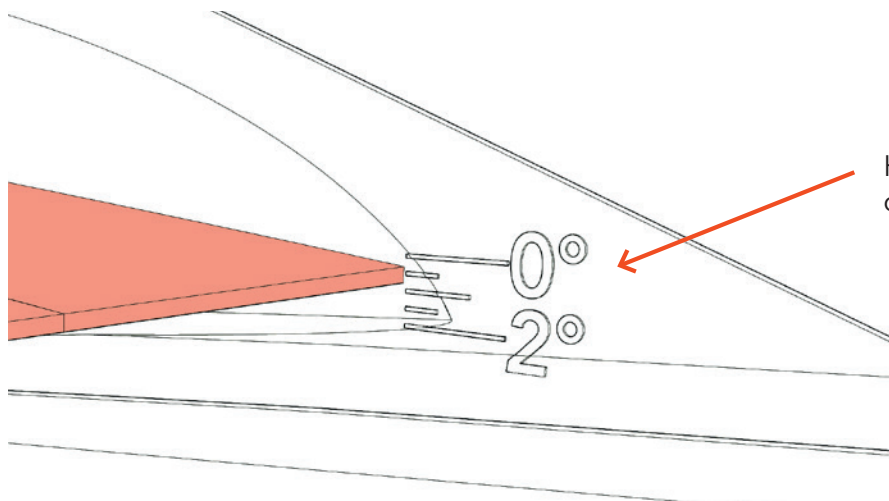
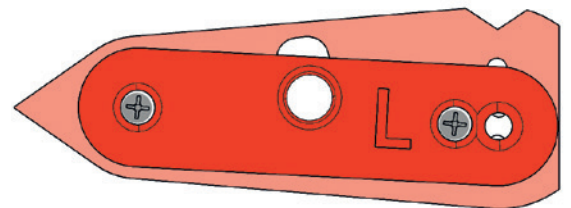
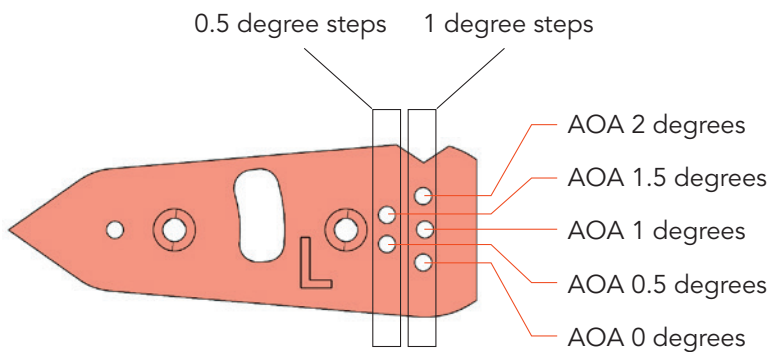

Here on the fuselage you can check if the setting is correct.

Aileron Servo mounting

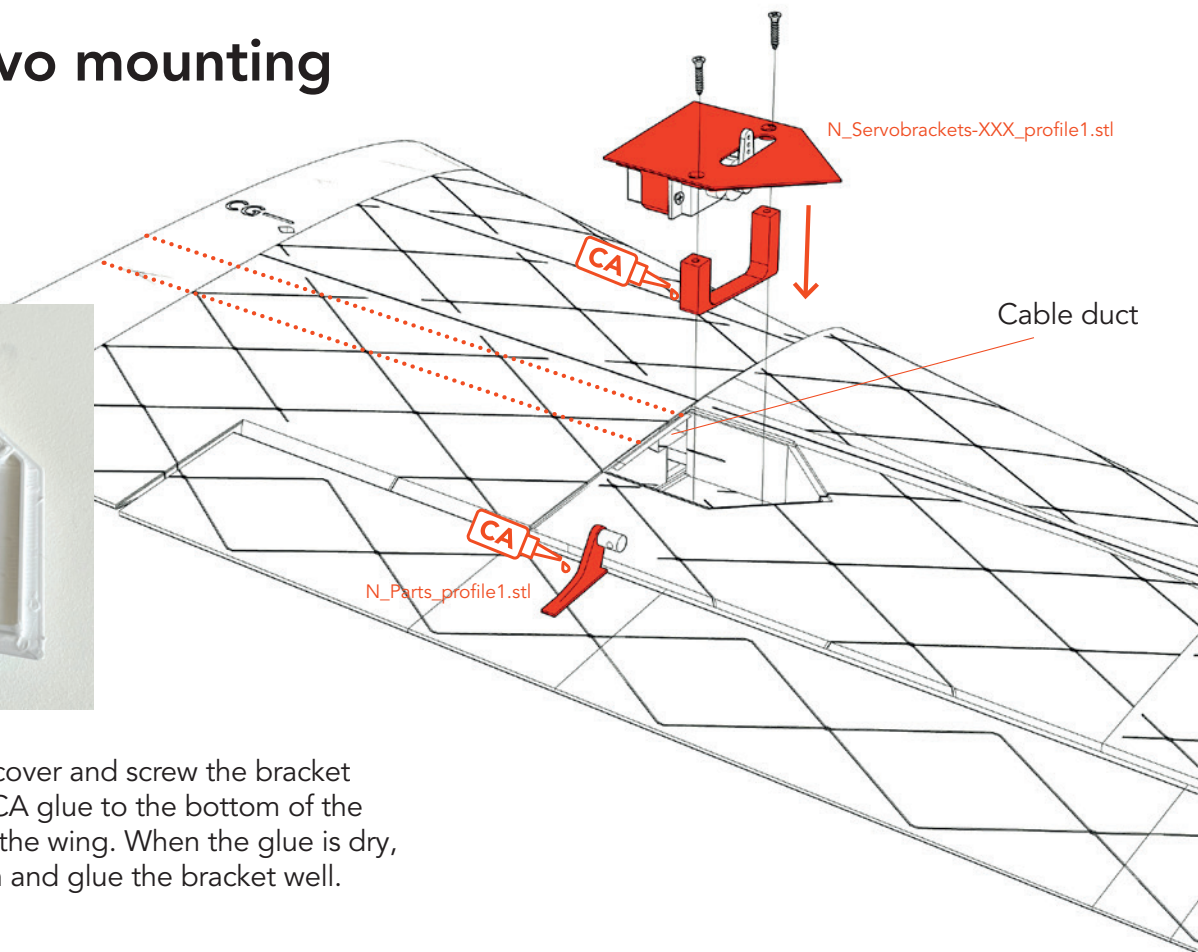
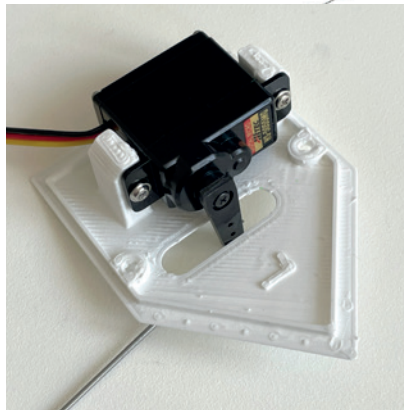

Mount the servo in the cover and screw the bracket to it. Then apply some CA glue to the bottom of the bracket and glue it into the wing. When the glue is dry, unscrew the cover again and glue the bracket well.

RC components

Attach the Controller, receiver and battery with self-adhesive Velcro.

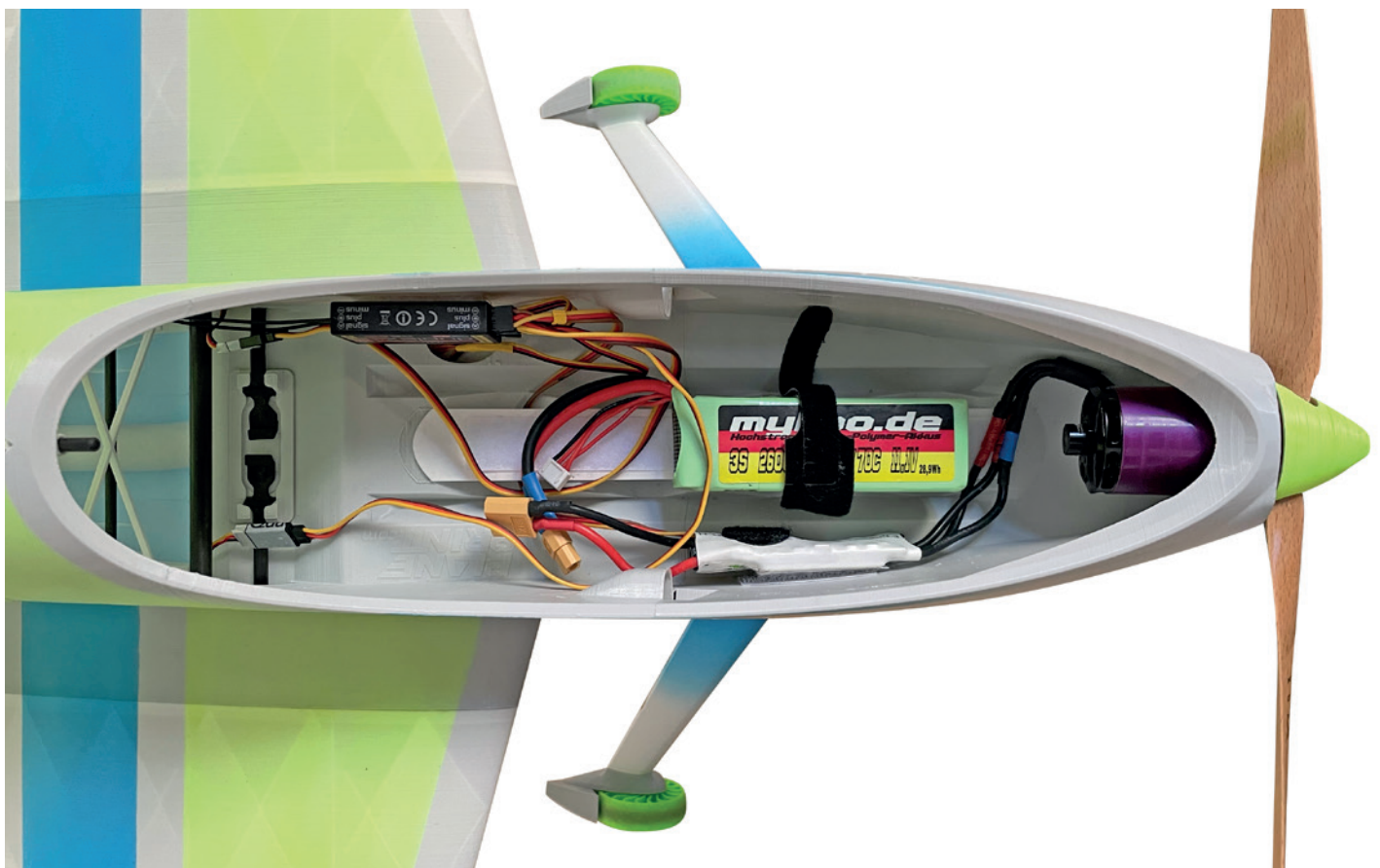

SETTINGS FOR FLYING

After installing the electronics and setting up the transmitter, check that the control surfaces are aligned correctly. Set the transmitter trim to zero. Align all rudders to zero position. Change the position of the moving parts by changing the length of the linkage from the servo arm to the control horn. In-flight adjustments can be made later with the trim.

Setting the servo travel

AILERON up: 17 mm, down: 17 mm

ELEVATOR up: 13 mm, down: 13 mm

RUDDER both sides: 33 mm

(These are only approximate figures, as the Notos is aimed at experienced pilots.)

Expo setting

AILERON 40 %

ELEVATOR 40 %

RUDDER 30 %

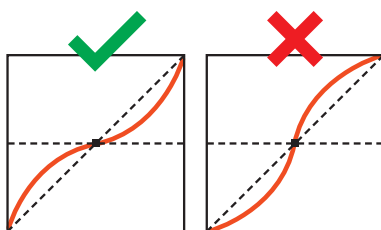

(for some remote controls a minus has to be in front of the number)

Center of Gravity (CG)

The aircraft must balance 107 mm/4.21 inches behind the leading edge (see markings on the fuselage). For the first flight we recommend to move the center of gravity about 5 mm/0.2 inches further forward.

NOTE Since many things can be adjusted according to individual preferences in the Notos, this information is only a basic recommendation.

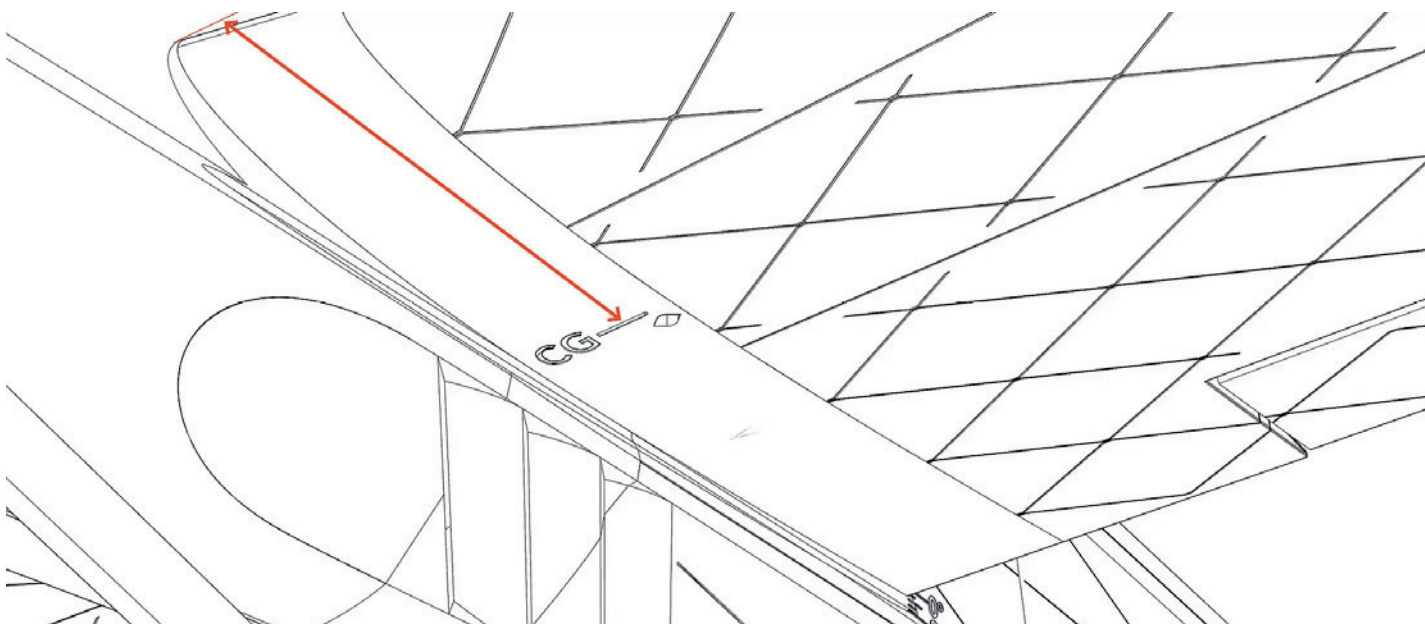

Flight timer

Flight time will vary depending on the battery size. Expect 5 minutes under normal circumstances; however, it may be possible to fly for much longer. It is a good idea to be conservative with the flight timer until you gain experience with your airplane.

TECHNICAL SPECIFICATIONS

WINGSPAN 1300 mm/51 inches

LENGHT 1300 mm/51 inches

FLIGHT WEIGHT 1470 grams (with 3S/2700MaH-Battery)

AGE RECOMMENDATION 14+

**NOT FOR CHILDREN UNDER 14 YEARS.
THIS IS NOT A TOY!**

By using the download data, an RC model airplane, called „model“ for short, can be manufactured using a 3D printer. As a user of this model, only you are responsible for safe operation that does not endanger you or others, or that does not damage the model or property of others.

PLANEPRINT.com assumes no responsibility for damage to persons and property caused by pressure, transport or use of the product. Filaments, printing supplies, hardware or consumables that can not be used after faulty 3D printing will not be replaced by PLANEPRINT.com in any way.

When operating, always keep a safe distance from your model in all directions to avoid collisions and injuries.

This model is controlled by a radio signal. Radio signals can be disturbed from outside without being able to influence it. Interference can lead to a temporary loss of control.

Always operate your model on open terrains, far from cars, traffic and people.

Always follow the instructions and warnings for this product and any optional accessories (servos, receivers, motors, propellers, chargers, rechargeable batteries, etc.) carefully.

Keep all chemicals, small parts and electrical components out of the reach of children.

Avoid water contact with all components that are not specially designed and protected. Moisture damages the electronics.

Never take an item of the model or accessory in your mouth as this can lead to severe injuries or even death.

Never operate your model with low batteries in the transmitter or model.

Always keep the model in view and under control. Use only fully charged batteries.

Always keep the transmitter switched on when the model is switched on.

Always remove the battery before disassembling the model.

Keep moving parts clean and dry at all times.

Always allow the parts to cool before touching them.

Always remove the battery after use.

Make sure that the Failsafe is properly set before the flight.

Never operate the model with damaged wiring.

Never touch moving parts.

We develop our models to the best of our knowledge and belief. We accept no liability for consequential damage and injuries caused by improper use. **Please be careful when handling motors, batteries and propellers** and only move your model with insurance and in approved places!

**PLANE
PRINT.com**

very light 3d printable rc planes